

\*ALL LINE PIPING TO BE 1 1/4" PIPE\*  
 \*ALL DROPS FOR PENDENT HEADS TO BE 1" PIPE\*

CPVC PIPE  
 STEEL PIPE

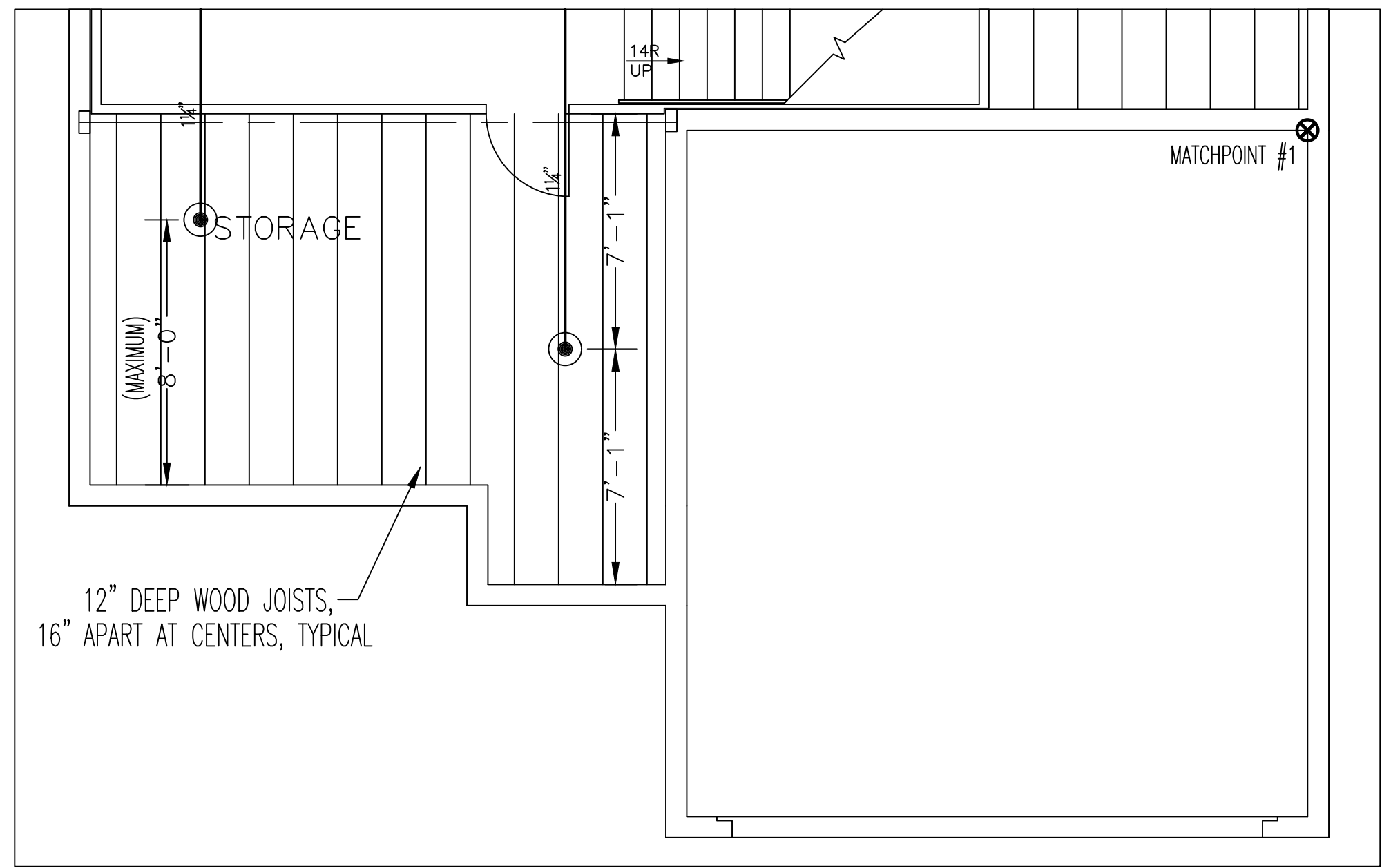

OPT. FRONT ELEVATION "B"

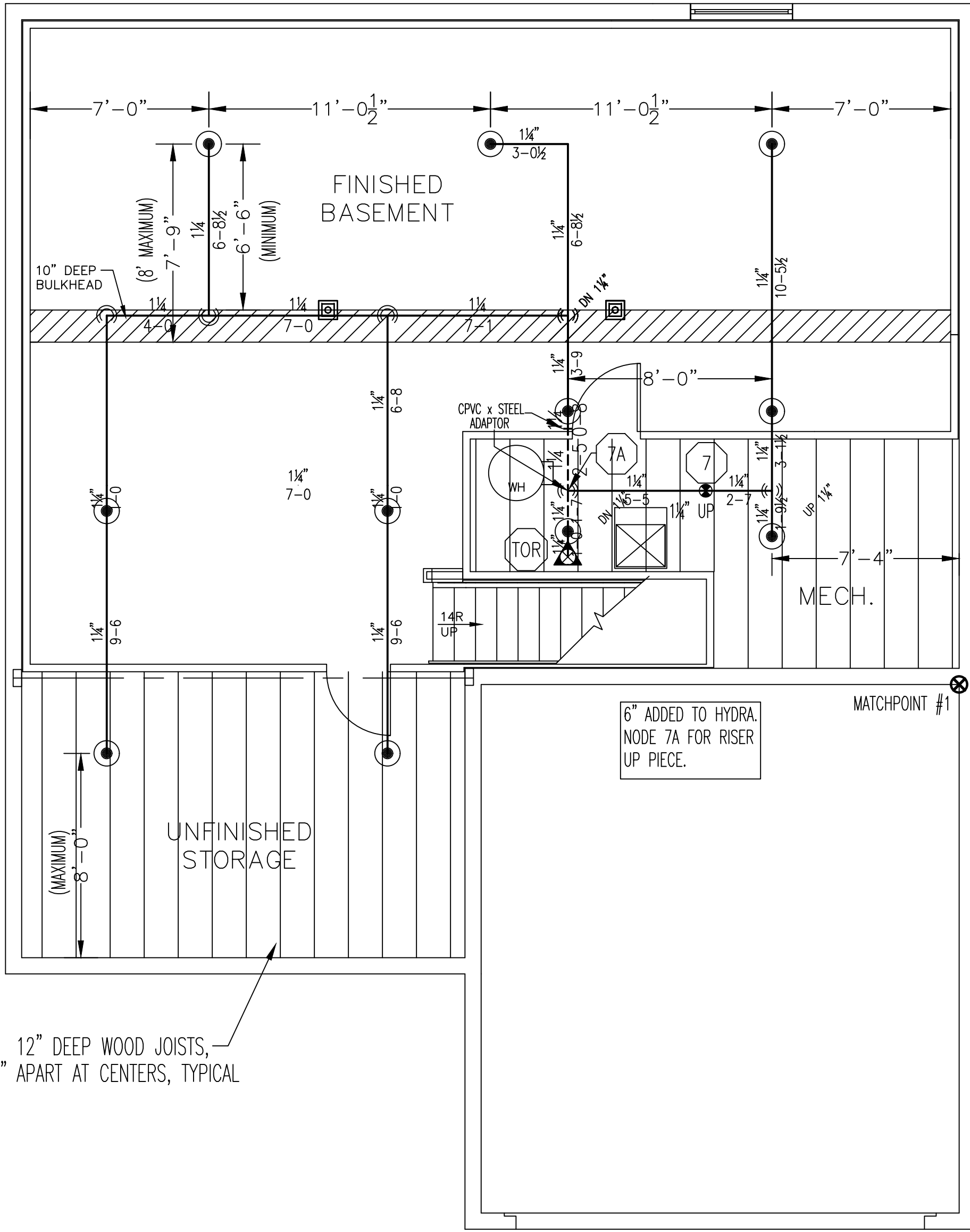

BASEMENT

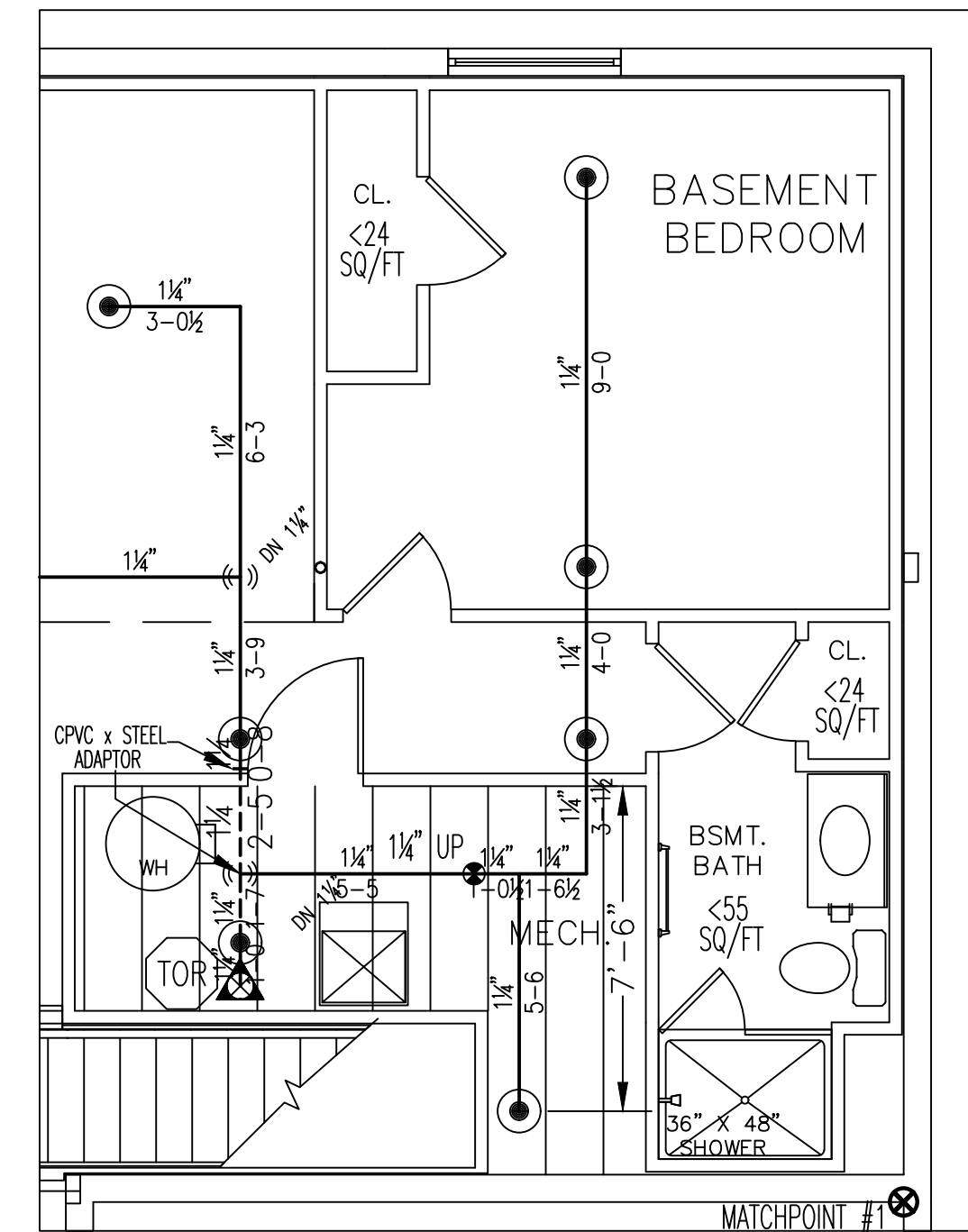

OPT. BASEMENT BEDROOM W/BATH

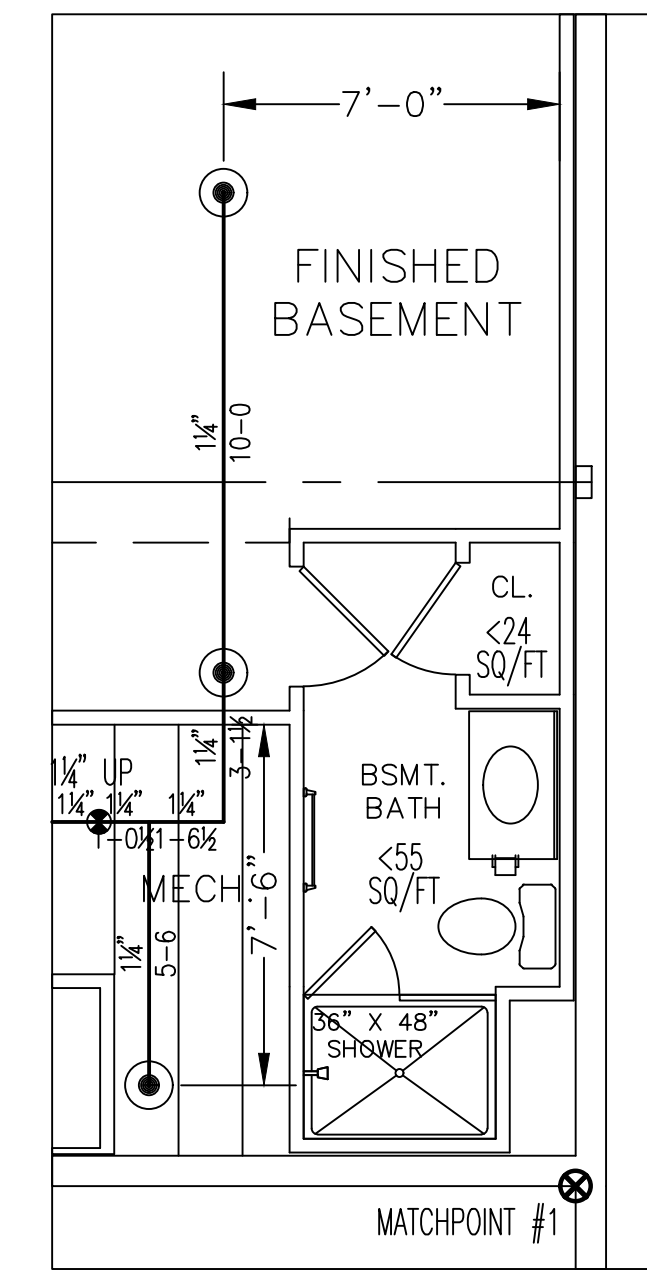

OPT. BASEMENT BATH

AS-BUILT  
 01/25/2021  
 FPP2021-00386

SPRINKLERS				DESIGN CRITERIA				SPECIALTY ITEMS				SYMBOLS				PLAN REVISIONS			
SYMBOL	MANUF/MODEL	TEMP.	FINISH	TOTAL	NFPA REF. #130	TYPE SYS.	HAZARD	RESIDUAL PSI	FLOW TEST:	FIRE PUMP:	F.D.C.:	TYPE:	DATE:	BY:	DESCRIPTION:				
⊙	1/4" REC. PEND. VIKING / QR VK488	155 DEG	WHITE	11		WET			STATIC PSI			⊙	01/25/21	WML	1.AS-BUILT OPTION LAYOUT HAS BEEN PROVIDED				
⊗	1/4" REC. PEND. VIKING / QR VK488	175 DEG	WHITE	0		HAZARD LIGHT HAZARD			RESIDUAL PSI			⊗			STUDY OPT WITH POWDER ROOM AND NOW A PANTRY THAT REQUIRED COVERAGE.				
▽	1/4" REC. SIDEWALL VIKING / QR VK488	155 DEG	WHITE	0		DENSITY .05			⊙ FLOW			⊙			THAT REQUIRED COVERAGE.				
▽	1/4" REC. SIDEWALL VIKING / QR VK488	175 DEG	WHITE	0		REMOTE AREA	2 HEADS		HYDRANT ELEV.			⊙							
						MAX. S.F./HD.	256-288		HYD. LOW GRAD.			⊙							
						K FACTOR	4.0-4.9		HYD. HIGH GRAD.			⊙							
						C FACTOR	120 - 150		ADJ STATIC PSI			⊙							
									ADJ RESID. PSI			⊙							
									INFO BY			⊙							
									INSIDE HOSE	N/A		⊙							
									OUTSIDE HOSE			⊙							
JOB TOTAL																			
	40			11															

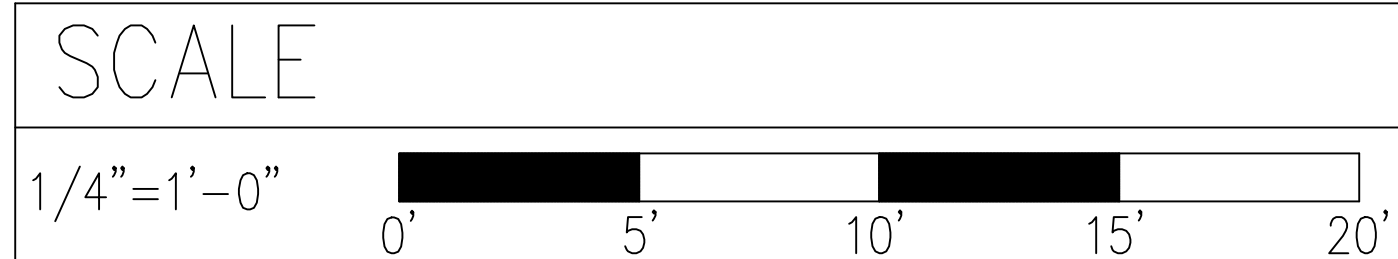

JOB NAME: BLACKBURN HUDSON MODEL HOME 11249 WHEELER RIDGE DR MANASSAS, VA 20109

DATE: 12-02-2020 SCALE: 1/4"=1'-0" CONTRACT NO: 20-0158 APPROVALS: PRINCE WILLIAM COUNTY F.M.O.

PLAN NORTH DRAWN BY: WML REVIEWED BY: NVR, INC. CONTRACTOR: NVR, INC.

AREA: LOT 71 BASEMENT CAD FILE: BLACKBURNSUBMIT

PERMIT NO: BLD2021-03547 CONTRACTOR PHONE: 540-428-8712

**BUILDERS FIRE SOLUTIONS**  
 225 ELM STREET, WARRENTON, VA 20186 (540) 428-8712  
 AUTOMATIC FIRE PROTECTION SYSTEMS  
 DESIGN INSTALLATION SERVICE

**HYDRAULICALLY CALCULATED SYSTEM**

THIS SYSTEM AS SHOWN ON SHEET 2 OF 5  
 COMPANY PRINT NO. 20-0158 DATED 12-02-20  
 FOR 1ST FLOOR DINING AREA REMOTE #2  
 AT 11249 WHEELER RIDGE DR CONTRACT NO. 02158  
 IS DESIGNED TO DISCHARGE AT A RATE OF .05 GPM (L/MIN) PER SQ FT (M2) OF FLOOR AREA OVER A MAXIMUM AREA OF 6000 SQ FT (M2) WHEN SUPPLIED WITH WATER AT THE RATE OF 200 GPM (L/MIN) AT 100 PSI (6.9 BAR) AT THE BASE OF THE RISER HOSE STREAM ALLOWANCE OF 100 GPM (L/MIN) OCCUPANCY CLASSIFICATION (LIGHT HAZARD) COMMODITY CLASSIFICATION (N/A) MAXIMUM STORAGE HEIGHT (N/A)

INSTALLED BY: BUILDERS FIRE SOLUTIONS  
 SAFETY MARGIN: 14.658 PSI  
 PENDENT HEADS: 16' x 16' SPACING

\*ALL LINE PIPING TO BE 1 1/4" PIPE\*  
 \*ALL DROPS FOR PENDENT HEADS TO BE 1" PIPE\*

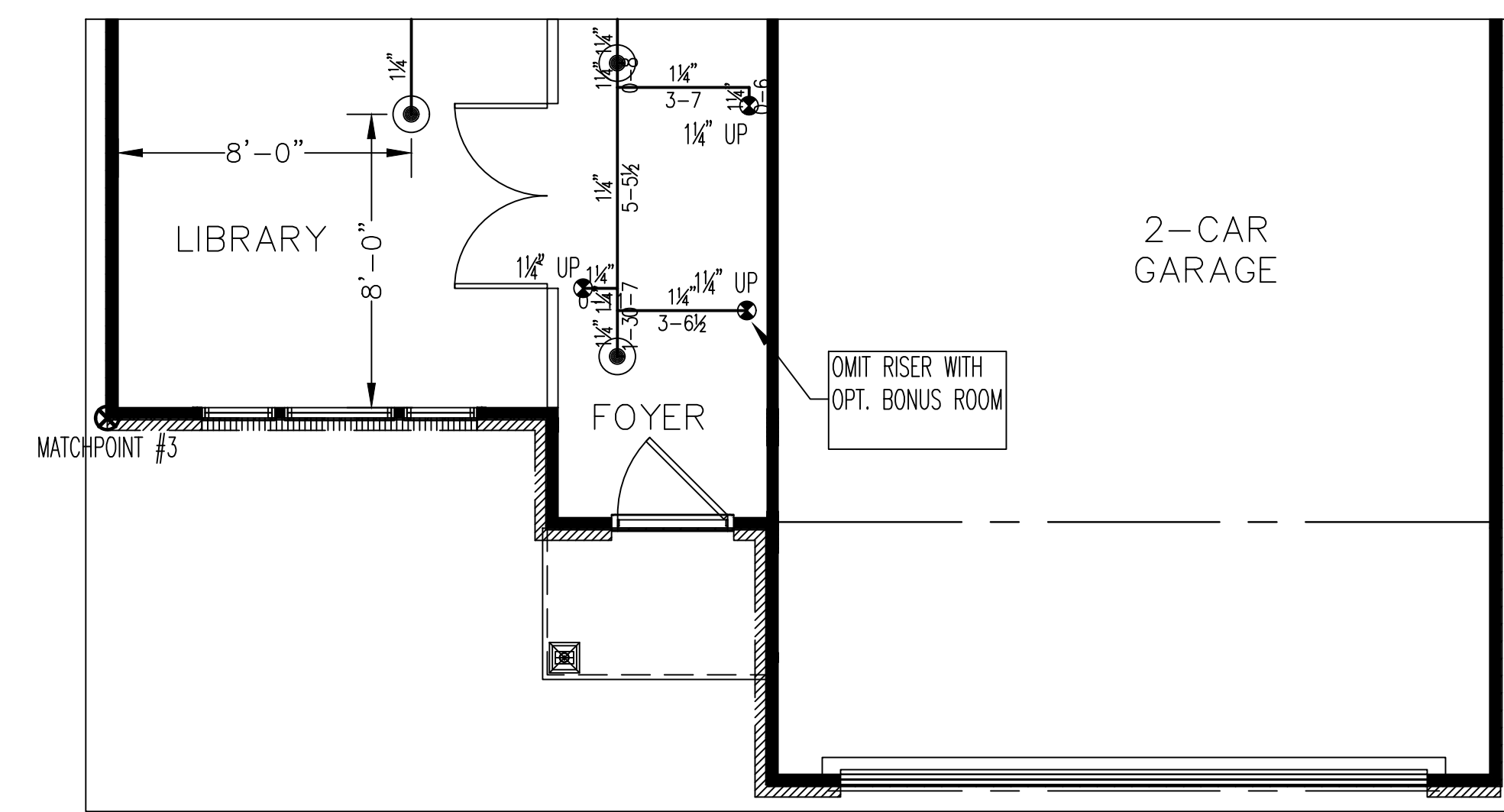
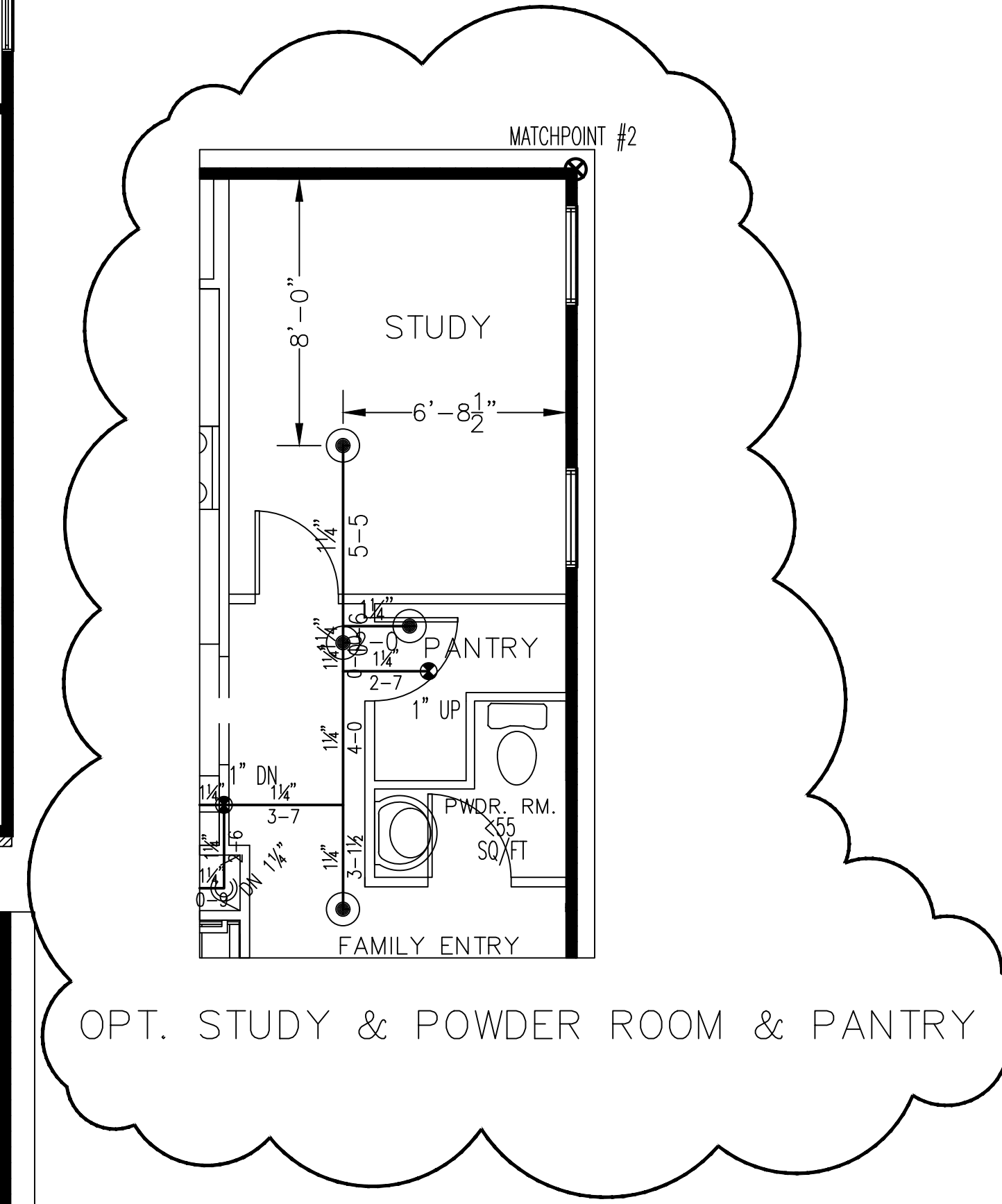
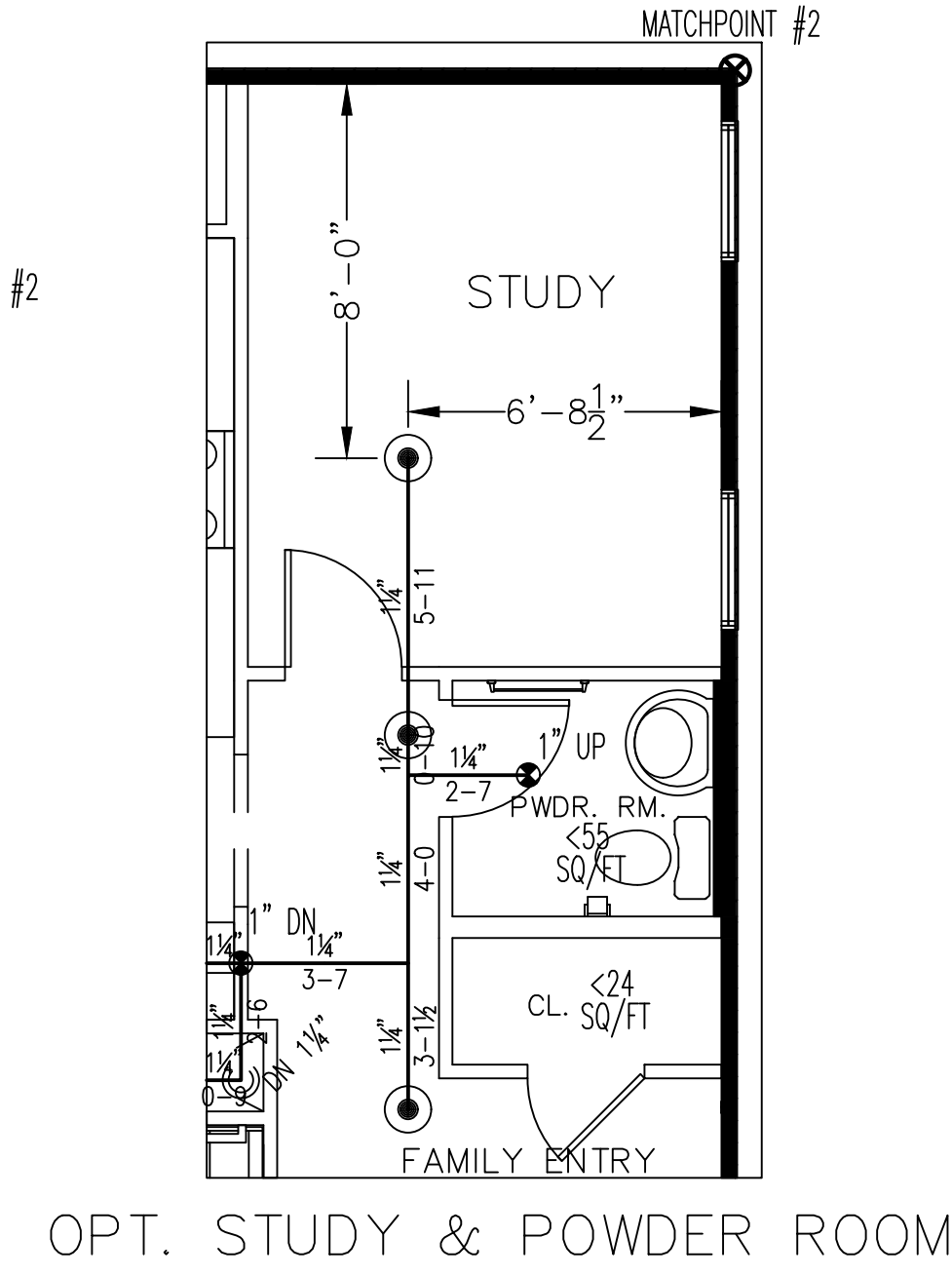
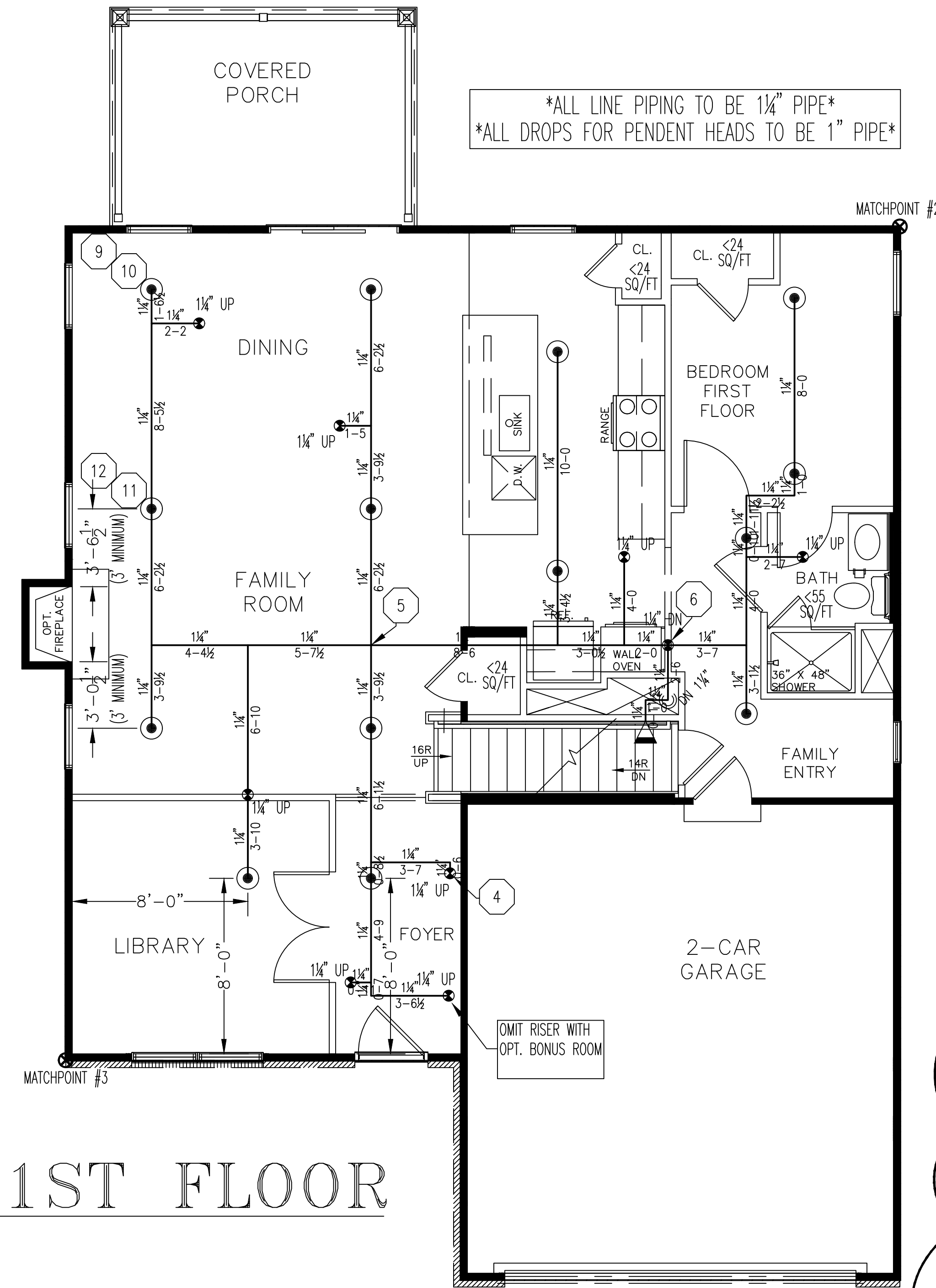
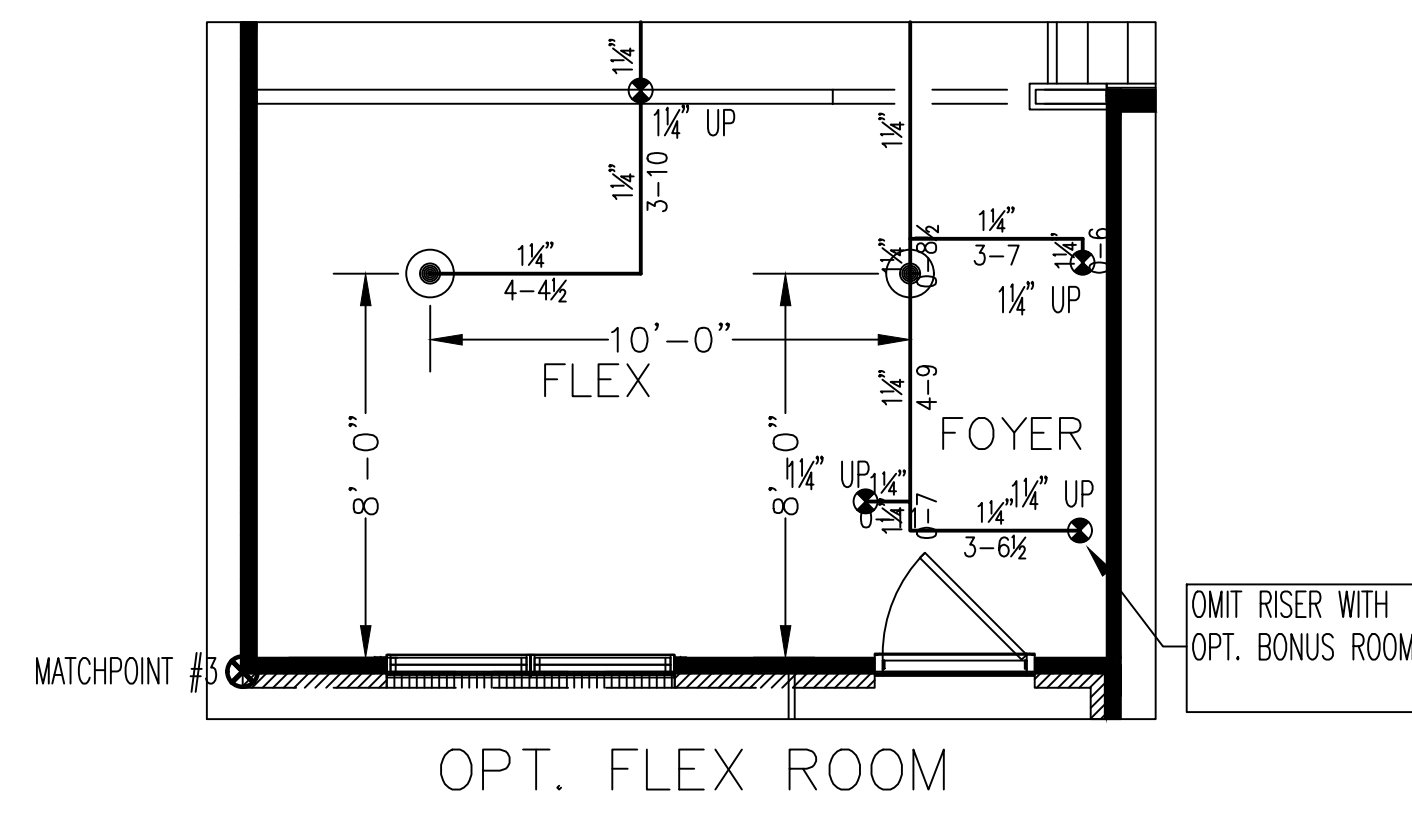

AS-BUILT  
 01/25/2021  
 FPP2021-00386

SPRINKLERS				DESIGN CRITERIA				SPECIALTY ITEMS				SYMBOLS				PLAN REVISIONS			
SYMBOL	MANUF./MODEL	TEMP.	FINISH	TOTAL	NFPA REF. #130	TYPE SYS.	WET	FLOW TEST:	FIRE PUMP:	F.D.C.:	TYPE:	DATE:	BY:	DESCRIPTION:	DATE:	BY:	DESCRIPTION:		
⊙	1/4" REC. PEND. VIKING / QR VK468	155 DEG	WHITE	14		HAZARD	LIGHT HAZARD	STATIC PSI	RATED FLOW:		TOP OF SPRINKLER RISER ASSEMBLY	01/25/21	WML	1.4S-BUILT OPTION LAYOUT HAS BEEN PROVIDED					
⊗	1/4" REC. PEND. VIKING / QR VK468	175 DEG	WHITE	0		HAZARD	LIGHT HAZARD	RESIDUAL PSI	RATED BOOST:		MATCH POINT FOR LAYOUT OPTIONS			STUDY OPT WITH POWDER ROOM AND NOW A PANTRY					
⊙	1/4" REC. SIDEWALL VIKING / QR VK468	155 DEG	WHITE	1		DENSITY	.05	⊙ FLOW	SUCT. X DIST.		RISE/DROP IN PIPE ELEVATION			THAT REQUIRED COVERAGE.					
⊙	1/4" REC. SIDEWALL VIKING / QR VK468	175 DEG	WHITE	0		REMOTE AREA	2 HEADS	HYDRANT ELEV.	RELIEF VALVE:		HYDRAULIC NODE								
						MAX. S.F./HD.	256-288	HYD. LOW GRAD.	FUEL TANK:										
						K FACTOR	4.0-4.9	HYD. HIGH GRAD.	MUFFLER:										
						C FACTOR	120 - 150	ADJ STATIC PSI	TEST HEADER:										
						INSIDE HOSE	N/A	ADJ RESID. PSI	TYPE:										
						OUTSIDE HOSE		INFO BY:	SIZE:										
									FINISH:										



JOB NAME: BLACKBURN HUDSON MODEL HOME 11249 WHEELER RIDGE DR MANASSAS, VA 20109

DATE: 12-02-2020 SCALE: 1/4"=1'-0" CONTRACT NO: 20-0158 APPROVALS: PRINCE WILLIAM COUNTY F.M.O.

PLAN NORTH DRAWN BY: WML REVIEWED BY: NVR, INC. CONTRACTOR: BLACKBURN SUBMIT

AREA: LOT 71: 1ST FLOOR CAD FILE: BLACKBURN SUBMIT

PERMIT NO: BLD2021-03547 CONTRACTOR PHONE: 540-428-8712

DATE: 01/25/21 BY: WML DESCRIPTION: 1.4S-BUILT OPTION LAYOUT HAS BEEN PROVIDED

DATE: 01/25/21 BY: WML DESCRIPTION: STUDY OPT WITH POWDER ROOM AND NOW A PANTRY THAT REQUIRED COVERAGE.

SCALE: 1/4"=1'-0" 0' 5' 10' 15' 20'

**BUILDERS FIRE SOLUTIONS**  
 225 ELM STREET, WARRENTON, VA 20186 (540) 428-8712  
 AUTOMATIC FIRE PROTECTION SYSTEMS  
 DESIGN INSTALLATION SERVICE

\*ALL LINE PIPING TO BE 1 1/4" PIPE\*  
 \*ALL DROPS FOR PENDENT HEADS TO BE 1" PIPE\*

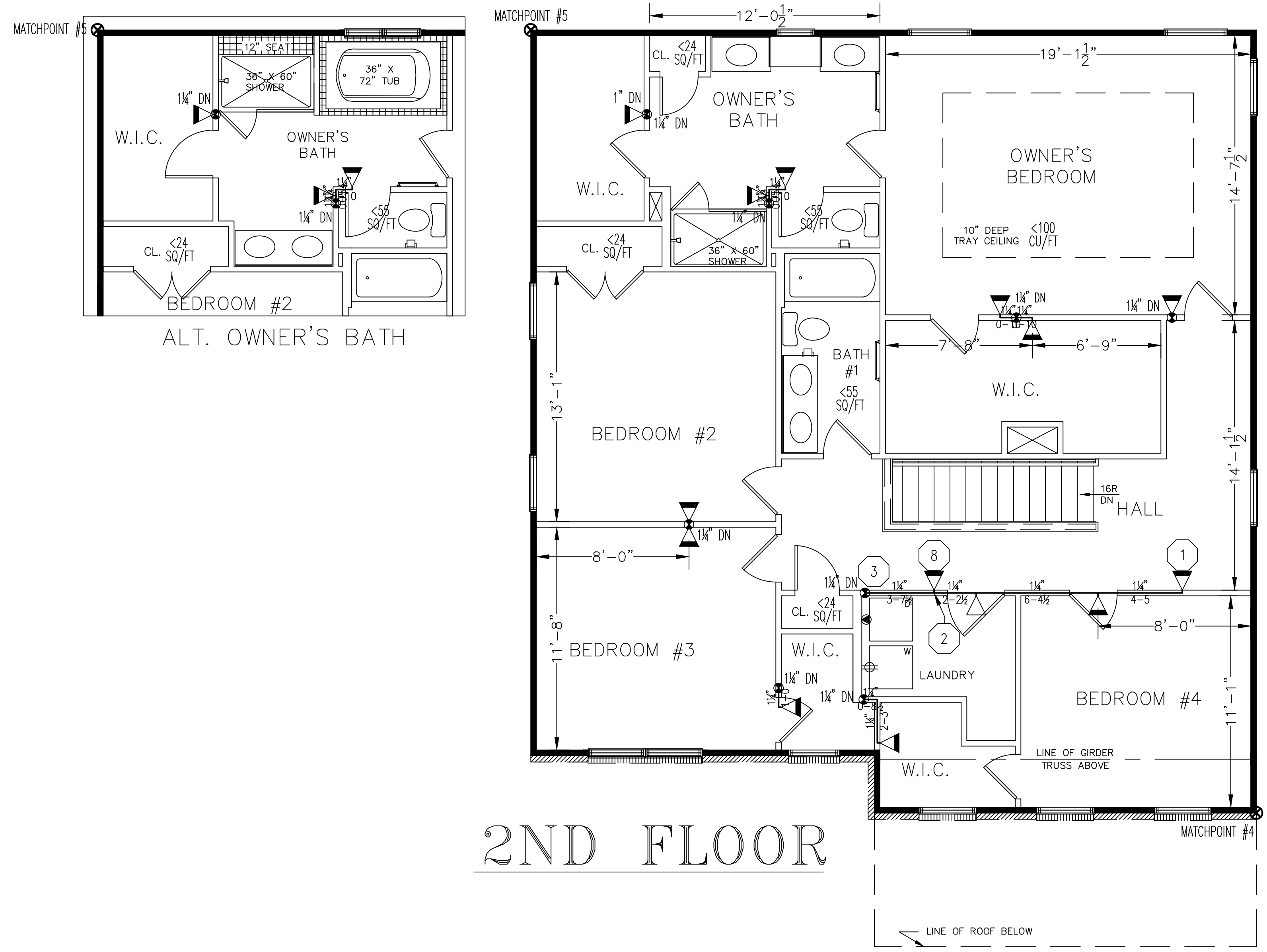

**HYDRAULICALLY CALCULATED SYSTEM**

THIS SYSTEM AS SHOWN ON SHEET 3 OF 5  
 COMPANY PRINT NO [20-0158] DATED [12-02-20]  
 FOR [2ND FLOOR HALL REMOTE #1]  
 AT [11249 WHEELER RIDGE DR] CONTRACT NO [0158]  
 IS DESIGNED TO DISCHARGE AT A RATE OF [0.5] GPM  
 (L/MIN) PER SQ FT (M2) OF FLOOR AREA OVER A  
 MAXIMUM AREA OF [6.528] SQ FT (M2) WHEN SUPPLIED  
 WITH WATER AT THE RATE OF [26.152] GPM (L/MIN)  
 AT [57.052] PSI (BARS) AT THE BASE OF THE RISER  
 HOSE STREAM ALLOWANCE OF [10/21] GPM (L/MIN)  
 OCCUPANCY CLASSIFICATION [LIGHT HAZARD]  
 COMMODITY CLASSIFICATION [N/A]  
 MAXIMUM STORAGE HEIGHT [N/A]

INSTALLED BY: BUILDERS FIRE SOLUTIONS  
 SAFETY MARGIN: 5.719 PSI  
 SIDEWALL HEADS: 16' x 16' SPACING

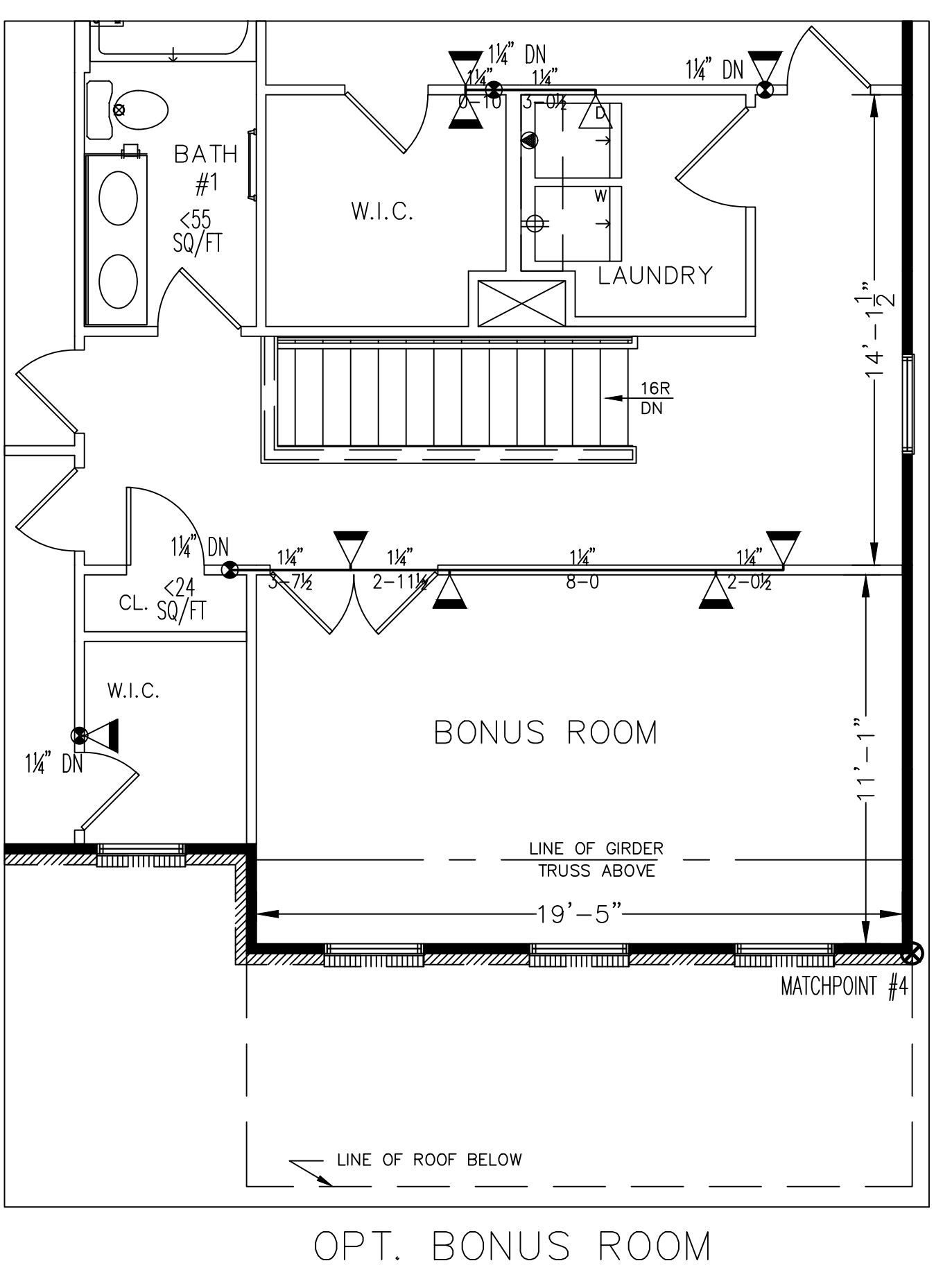
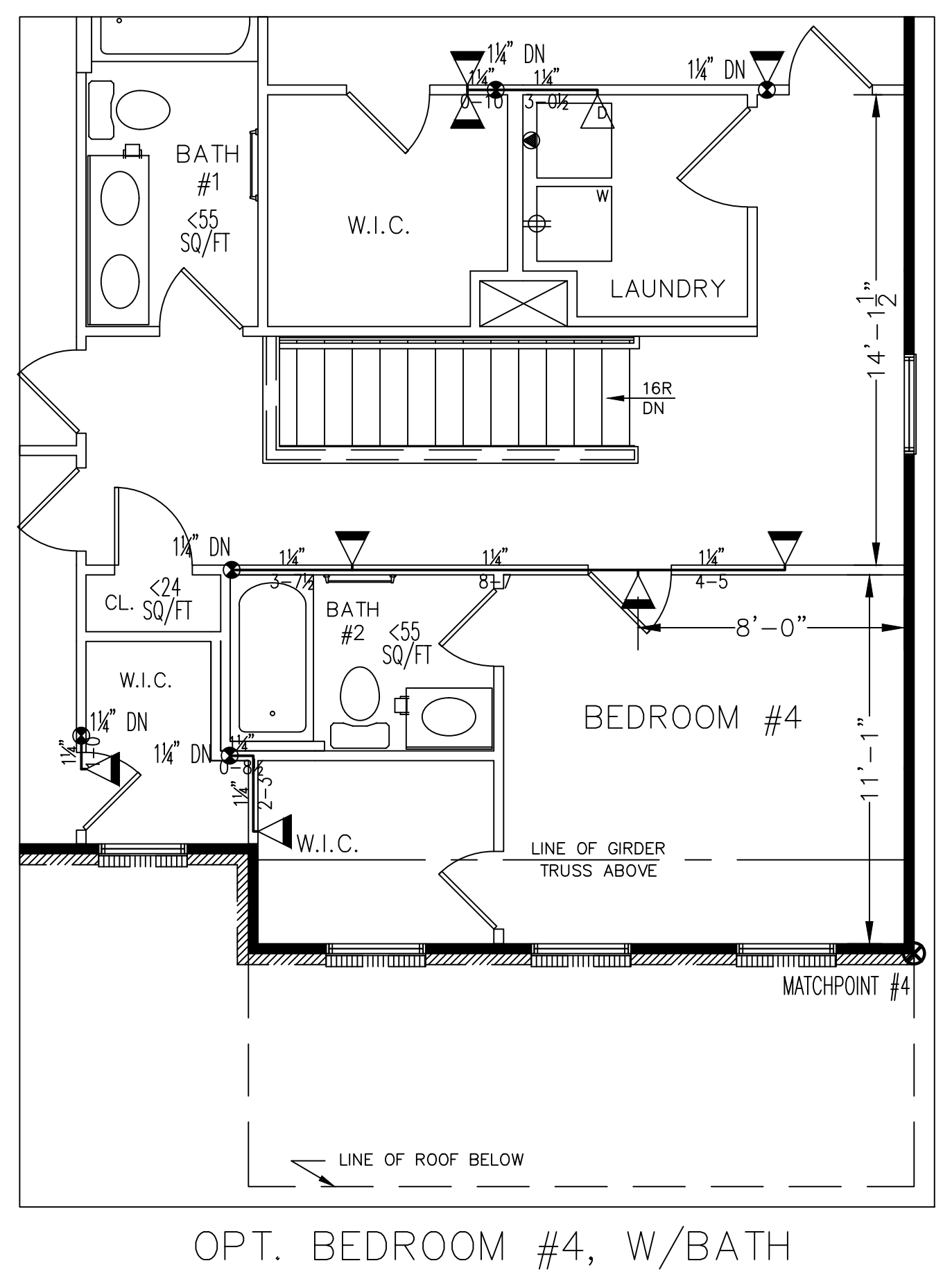
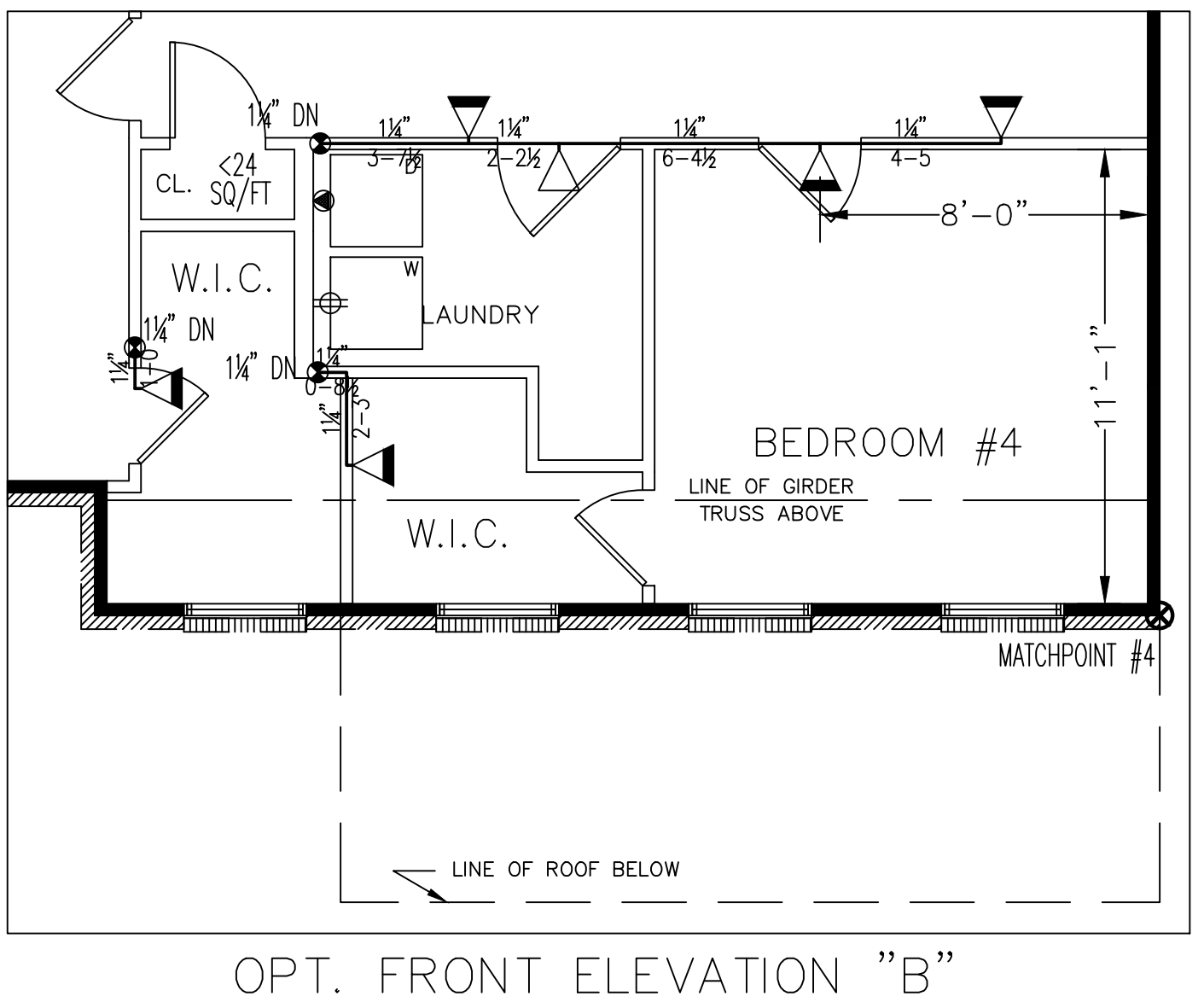

AS-BUILT  
 01/25/2021  
 FPP2021-00386

SPRINKLERS				DESIGN CRITERIA				SPECIALTY ITEMS				SYMBOLS				PLAN REVISIONS																				
SYMBOL	MANUF/MODEL	TEMP.	FINISH	TOTAL	NFPA REF. #130	TYPE SYS.	HAZARD	DENSITY	REMOTE AREA	MAX. S.F./HD.	K FACTOR	C FACTOR	INSIDE HOSE	OUTSIDE HOSE	FIRE PUMP:	RATED FLOW:	RATED BOOST:	SUCT. X DIST.	RELIEF VALVE:	FUEL TANK:	MUFFLER:	TEST HEADER:	TYPE:	SIZE:	FINISH:	F.D.C.:	TYPE:	SIZE:	FINISH:	ALARM VALVE:	OTHER:	DATE:	BY:	DESCRIPTION:		
⊙	1/4" REC. PEND. VIKING / QR VK468	155 DEG	WHITE	0		WET							N/A																					01/25/21	WML	1.4S-BUILT OPTION LAYOUT HAS BEEN PROVIDED
⊗	1/4" REC. PEND. VIKING / QR VK468	175 DEG	WHITE	0		HAZARD LIGHT HAZARD																													STUDY OPT WITH POWDER ROOM AND NOW A PANTRY	
▽	1/4" REC. SIDEWALL VIKING / QR VK468	155 DEG	WHITE	13																															THAT REQUIRED COVERAGE.	
▽	1/4" REC. SIDEWALL VIKING / QR VK468	175 DEG	WHITE	1																																
JOB TOTAL				40	TOTAL THIS SHEET				14	INSIDE HOSE				N/A	INFO BY																					

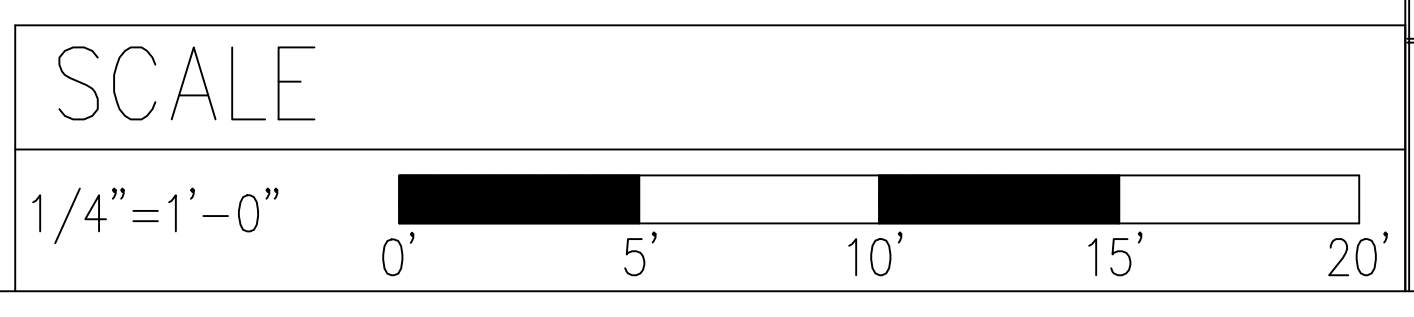

JOB NAME: BLACKBURN  
 HUDSON MODEL HOME  
 11249 WHEELER RIDGE DR  
 MANASSAS, VA 20109

DATE: 12-02-2020  
 PLAN NORTH

SCALE: 1/4"=1'-0"

CONTRACT NO: 20-0158  
 REVIEWED BY:

APPROVALS: PRINCE WILLIAM COUNTY F.M.O.  
 CONTRACTOR: NVR, INC.

AREA: LOT 71: 2ND FLOOR  
 PERMIT NO: BLD2021-03547

CAD FILE: BLACKBURNSUBMIT  
 CONTRACTOR PHONE: 540-428-8712

DRWG NO: 3 OF 5

**BUILDERS FIRE SOLUTIONS**  
 225 ELM STREET, WARRENTON, VA 20186 (540) 428-8712  
 AUTOMATIC FIRE PROTECTION SYSTEMS  
 DESIGN INSTALLATION SERVICE



## TECHNICAL DATA

## FREEDOM® RESIDENTIAL PENDENT SPRINKLER VK468 (K4.9)

The Viking Corporation, 210 N Industrial Park Drive, Hastings MI 49058

Telephone: 269-945-9501 Technical Services: 877-384-5464 Fax: 269-818-1680 Email: techsvcs@vikingcorp.com

Visit the Viking website for the latest edition of this technical data page [www.vikinggroupinc.com](http://www.vikinggroupinc.com)

### 1. DESCRIPTION

Viking Freedom® Residential Pendent Sprinkler VK468 is a small, thermosensitive, glass-bulb residential sprinkler available in several different finishes and temperature ratings to meet varying design requirements. The Electroless Nickel PTFE (ENT) coating has been investigated for installation in corrosive atmospheres and is C-UL-US-EU Listed as corrosion resistant as indicated in the Approval Chart. The orifice design, with a K-Factor of 4.9 (70.6 metric†), allows efficient use of available water supplies for the hydraulically designed fire-protection system. The glass bulb operating element and special deflector characteristics meet the challenges of residential sprinkler standards.

### 2. LISTINGS AND APPROVALS



**UL Listed (C-UL-US-EU):** Category VKKW



**VdS Approved**

**NYC Approved:** MEA 89-92-E, Volume 35

**UL Classified to:** NSF/ANSI Standard 61, Drinking Water System Components (MH48034).

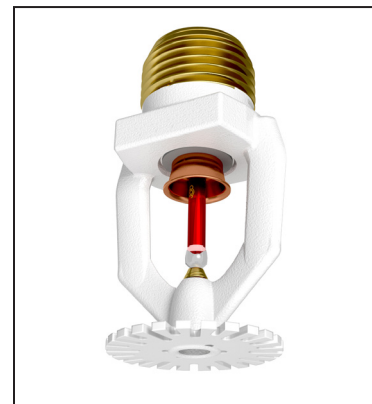

**WARNING:** Cancer and Reproductive Harm-  
[www.P65Warnings.ca.gov](http://www.P65Warnings.ca.gov)

Refer to the Approval Chart and Design Criteria for C-UL-US-EU Listing requirements that must be followed.

### 3. TECHNICAL DATA

#### Specifications:

Available since 2006.

Minimum Operating Pressure: Refer to the Approval Chart.

Maximum Working Pressure: 175 psi (12 bar). Factory tested hydrostatically to 500 psi (34.5 bar).

Thread size: 1/2" (15 mm) NPT

Nominal K-Factor: 4.9 U.S. (70.6 metric†)

†Metric K-factor measurement shown is in Bar. When pressure is measured in kPa, divide the metric K-factor shown by 10.0.

Glass-bulb fluid temperature rated to -65 °F (-55 °C)

Overall Length: 2-1/4" (58 mm)

#### Material Standards:

Frame Casting: Brass UNS-C84400 or QM Brass

Deflector: Brass UNS-C23000, Phosphor Bronze UNS-C51000, or Brass UNS-C26000

Bulb: Glass, nominal 3 mm diameter

Belleville Spring Sealing Assembly: Nickel Alloy, coated on both sides with Polytetrafluoroethylene (PTFE) Tape

Pip Cap and Insert Assembly: Copper UNS-C11000 and Stainless Steel UNS-S30400

Compression Screw: Brass UNS-C36000

For ENT coated sprinklers: Belleville spring - Exposed. Screw and Pipcap - ENT plated.

**Ordering Information:** (Also refer to the current Viking price list.)

**Sprinkler:** Base Part No. 13637

Order Sprinkler VK468 by first adding the appropriate suffix for the sprinkler finish and then the appropriate suffix for the temperature rating to the sprinkler base part number.

Finish Suffix: Brass = A, Chrome = F, White Polyester = M-/W, Black Polyester = M-/B, and ENT = JN

Temperature Suffix: 155 °F (68 °C) = B, 175 °F (79 °C) = D

For example, sprinkler VK468 with a Brass finish and a 155 °F (68 °C) temperature rating = Part No. 13637AB.

#### Available Finishes And Temperature Ratings:

Refer to Table 1.

**Accessories:** (Also refer to the Viking website.)

#### Sprinkler Wrenches:

A. Standard Wrench: Part No. 21475M/B (available since 2017)

B. Wrench for recessed sprinklers: Part No. 13577W/B\* (available since 2006)

C. Optional Protective Sprinkler Cap Remover/Escutcheon Installer Tool\*\* Part No. 15915 (available since 2010.)

\*A 1/2" ratchet is required (not available from Viking).

\*\*Allows use from the floor by attaching a length of 1" diameter CPVC tubing to the tool. Ideal for sprinkler cabinets. Refer to Bulletin F\_051808.

	<b>TECHNICAL DATA</b>	<b>FREEDOM® RESIDENTIAL PENDENT SPRINKLER VK468 (K4.9)</b>
---	-----------------------	--

**The Viking Corporation, 210 N Industrial Park Drive, Hastings MI 49058**  
**Telephone: 269-945-9501 Technical Services: 877-384-5464 Fax: 269-818-1680 Email: techsvcs@vikingcorp.com**  
**Visit the Viking website for the latest edition of this technical data page [www.vikinggroupinc.com](http://www.vikinggroupinc.com)**

**Sprinkler Cabinets:**

- A. Six-head capacity: Part No. 01724A (available since 1971)
- B. Twelve-head capacity: Part No. 01725A (available since 1971)

**4. INSTALLATION**

Refer to appropriate NFPA Installation Standards.

**5. OPERATION**

During fire conditions, the heat-sensitive liquid in the glass bulb expands, causing the glass to shatter, releasing the pip cap and sealing spring assembly. Water flowing through the sprinkler orifice strikes the sprinkler deflector, forming a uniform spray pattern to extinguish or control the fire.

**6. INSPECTIONS, TESTS AND MAINTENANCE**

Refer to NFPA 25 for Inspection, Testing and Maintenance requirements.

**7. AVAILABILITY**

The Viking Model VK468 Sprinkler is available through a network of domestic and international distributors. See The Viking Corporation web site for the closest distributor or contact The Viking Corporation.

**8. GUARANTEE**

For details of warranty, refer to Viking's current list price schedule or contact Viking directly.

**TABLE 1: AVAILABLE SPRINKLER TEMPERATURE RATINGS AND FINISHES**

Sprinkler Temperature Classification	Sprinkler Nominal Temperature Rating <sup>1</sup>	Maximum Ambient Ceiling Temperature <sup>2</sup>	Bulb Color
Ordinary	155 °F (68 °C)	100 °F (38 °C)	Red
Intermediate	175 °F (79 °C)	150 °F (65 °C)	Yellow

**Sprinkler Finishes:** Brass, Chrome, White Polyester, Black Polyester, and ENT

**Corrosion Resistant Coatings<sup>3</sup>:** ENT

**Footnotes**

- <sup>1</sup> The sprinkler temperature rating is stamped on the deflector.
- <sup>2</sup> Based on NFPA-13. Other limits may apply, depending on fire loading, sprinkler location, and other requirements of the Authority Having Jurisdiction. Refer to specific installation standards.
- <sup>3</sup> The corrosion resistant coatings have passed the standard corrosion test required by the approving agencies indicated in the Approval Chart. These tests cannot and do not represent all possible corrosive environments. Prior to installation, verify through the end-user that the coatings are compatible with or suitable for the proposed environment. For ENT coated sprinklers, the waterway is coated. Note that the spring is exposed on sprinklers with ENT coating.

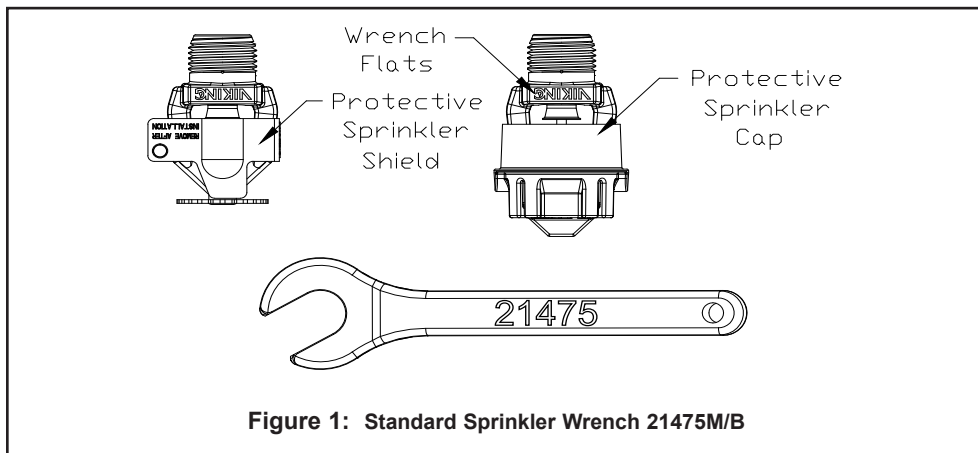

**Figure 1: Standard Sprinkler Wrench 21475M/B**



## TECHNICAL DATA

## FREEDOM® RESIDENTIAL PENDENT SPRINKLER VK468 (K4.9)

The Viking Corporation, 210 N Industrial Park Drive, Hastings MI 49058  
 Telephone: 269-945-9501 Technical Services: 877-384-5464 Fax: 269-818-1680 Email: techsvcs@vikingcorp.com  
 Visit the Viking website for the latest edition of this technical data page www.vikinggroupinc.com

### Approval Chart Viking VK468, 4.9 K-Factor Residential Pendent Sprinkler

For systems designed to NFPA 13D or NFPA 13R. For systems designed to NFPA 13, refer to the design criteria. For Ceiling types refer to current editions of NFPA 13, 13R or 13D

Sprinkler Base Part Number <sup>1</sup>	SIN	NPT Thread Size		Nominal K-Factor		Maximum Water Working Pressure	Overall Length				
		Inches	mm	U.S.	metric <sup>2</sup>		Inches	mm			
13637	VK468	1/2	15	4.9	70.6	175 psi (12 bar)	2-1/4	58			
Max. Coverage Area <sup>4</sup> Ft.X Ft. (m X m)	Ordinary Temp Rating (155 °F/68 °C)		Intermediate Temp Rating (175 °F/79 °C)		Deflector to Ceiling	Installation Type	Listings and Approvals <sup>3</sup>				Minimum Spacing Ft. (m)
	Flow <sup>4</sup> GPM (L/min)	Pressure <sup>4</sup> PSI (bar)	Flow <sup>4</sup> GPM (L/min)	Pressure <sup>4</sup> PSI (bar)			C-UL-US-EU <sup>5</sup>	VdS	NYC <sup>6</sup>	NSF <sup>8</sup>	
12 X 12 (3.7 X 3.7)	13 (49.2)	7.0 (0.48)	13 (49.2)	7.0 (0.48)	1-1/8 to 2 inch	Standard surface-mounted escutcheons, or recessed with the Micromatic® Model E-1, E-2, or E-3 Recessed Escutcheon	See Foot-notes 7 and 10.	See Foot-notes 7 and 10.	See Foot-note 7.	See Foot-note 7.	8 (2.4)
14 X 14 (4.3 X 4.3)	13 (49.2)	7.0 (0.48)	13 (49.2)	7.0 (0.48)							
16 X 16 (4.9 X 4.9)	13 (49.2)	7.0 (0.48)	13 (49.2)	7.0 (0.48)							
18 X 18 (5.5 X 5.5)	17 (64.4)	12.0 (0.83)	17 (64.4)	12.0 (0.83)							
20 X 20 (6.1 X 6.1)	20 (75.7)	16.7 (1.15)	20 (75.7)	16.7 (1.15)							

#### Footnotes

- <sup>1</sup> Part number shown is the base part number. For complete part number, refer to Viking's current price schedule.
- <sup>2</sup> Metric K-factor measurement shown is when pressure is measured in Bar. When pressure is measured in kPa, divide the metric K-factor shown by 10.0.
- <sup>3</sup> This chart shows the listings and approvals available at the time of printing. Other approvals may be in process. Check with the manufacturer for any additional approvals. Refer also to Design Criteria.
- <sup>4</sup> For areas of coverage smaller than shown, use the "Flow" and "Pressure" for the next larger area listed. Flows and pressures listed are per sprinkler. The distance from sprinklers to walls shall not exceed one-half the sprinkler spacing indicated for the minimum "Flow" and "Pressure" used.
- <sup>5</sup> Listed by Underwriter's Laboratories, Inc. for use in the U.S., Canada, and European Union.
- <sup>6</sup> Accepted for use, City of New York Department of Buildings, MEA Number 89-92-E, Vol. 35.
- <sup>7</sup> Approved Finishes are: Brass, Chrome, White Polyester, and Black Polyester<sup>9</sup>
- <sup>8</sup> UL Classified to: NSF/ANSI Standard 61, Drinking Water System Components (MH48034).
- <sup>9</sup> Other paint colors are available on request with the same C-UL-US-EU listings as the standard finish colors.
- <sup>10</sup> Approved finish is Electroless Nickel PTFE (ENT). ENT is C-UL-US-EU Listed as corrosion resistant. ENT is available with standard surface-mounted escutcheons or the Micromatic Model E-1 Recessed Escutcheon.



**TECHNICAL DATA**

**FREEDOM® RESIDENTIAL  
PENDENT SPRINKLER  
VK468 (K4.9)**

The Viking Corporation, 210 N Industrial Park Drive, Hastings MI 49058  
 Telephone: 269-945-9501 Technical Services: 877-384-5464 Fax: 269-818-1680 Email: techsvcs@vikingcorp.com  
 Visit the Viking website for the latest edition of this technical data page www.vikinggroupinc.com

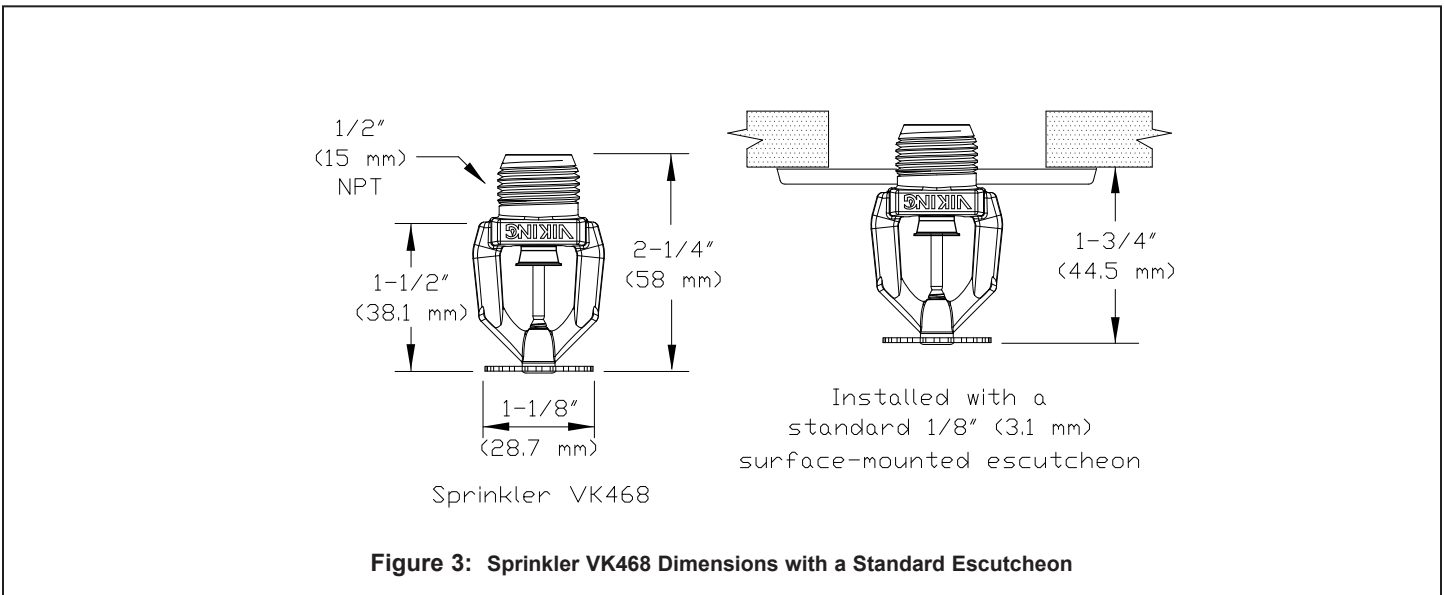
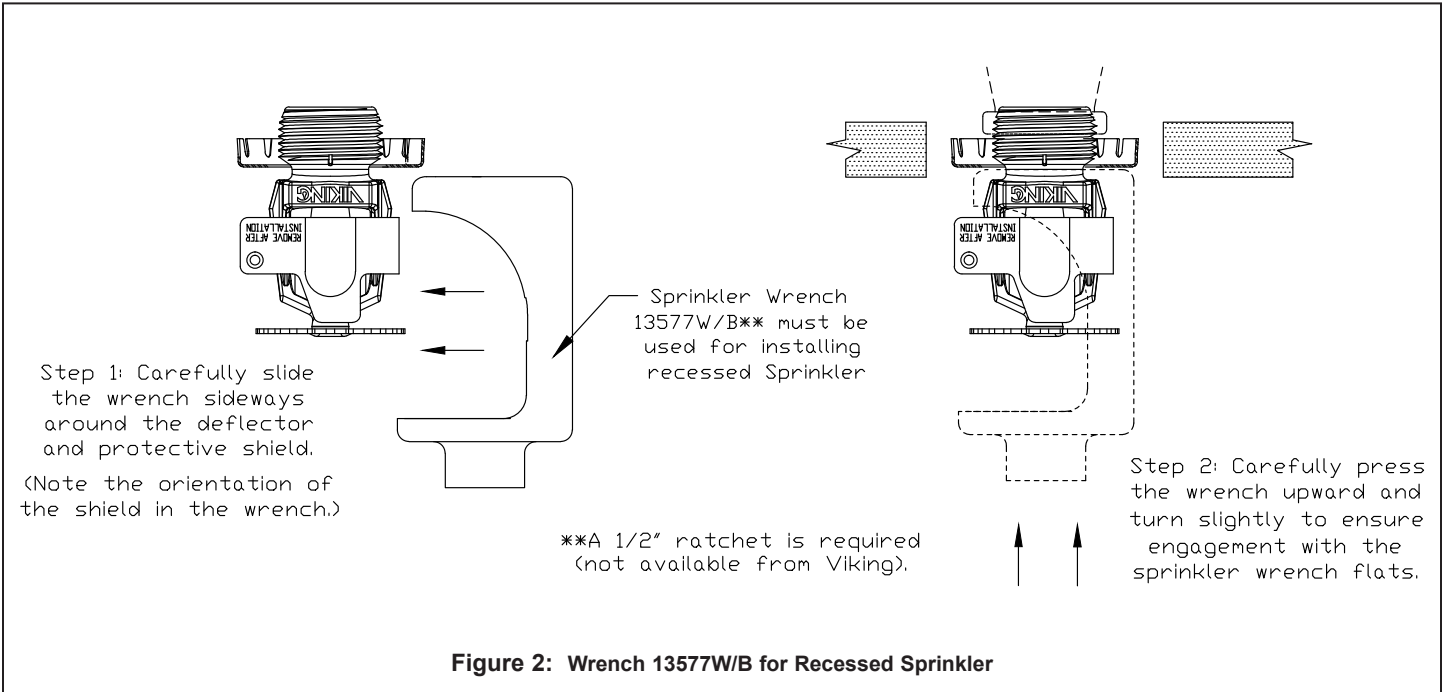



## TECHNICAL DATA

## FREEDOM® RESIDENTIAL PENDENT SPRINKLER VK468 (K4.9)

The Viking Corporation, 210 N Industrial Park Drive, Hastings MI 49058

Telephone: 269-945-9501 Technical Services: 877-384-5464 Fax: 269-818-1680 Email: techsvcs@vikingcorp.com

Visit the Viking website for the latest edition of this technical data page [www.vikinggroupinc.com](http://www.vikinggroupinc.com)

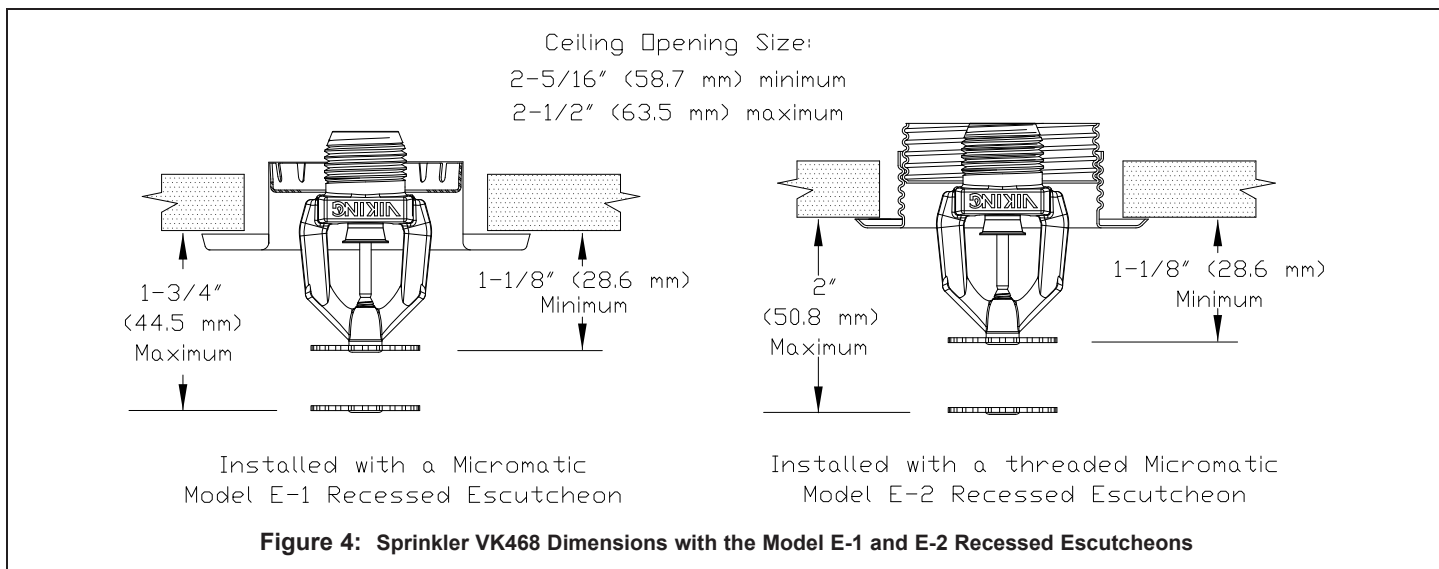

### DESIGN CRITERIA

(Also refer to the Approval Chart.)

#### UL Listing Requirements (C-UL-US-EU):

When using Viking Residential Pendent Sprinkler VK468 for systems designed to NFPA 13D or NFPA 13R, apply the listed areas of coverage and minimum water supply requirements shown in the Approval Chart.

For systems designed to NFPA 13: The number of design sprinklers is to be the four contiguous most hydraulically demanding sprinklers. The minimum required discharge from each of the four sprinklers is to be the greater of the following:

- The flow rates given in the Approval Chart for NFPA 13D and NFPA13R applications for each listed area of coverage, **or**
- Calculated based on a minimum discharge of 0.1 gpm/sq. ft. over the "design area" in accordance with sections 8.5.2.1 or 8.6.2.1.2 of NFPA 13.
- Minimum distance between residential sprinklers: 8 ft. (2.4 m).

**IMPORTANT:** Always refer to Bulletin Form No. F\_091699 - Care and Handling of Sprinklers. Also refer to Form No. F\_080614, F\_080415 and F\_080190 for general care, installation, and maintenance information. Viking sprinklers are to be installed in accordance with the latest edition of Viking technical data, the appropriate standards of NFPA, VdS, and any other similar Authorities Having Jurisdiction, and also with the provisions of governmental codes, ordinances, and standards, whenever applicable. Final approval and acceptance of all residential sprinkler installations must be obtained from the Authorities Having Jurisdiction.





# Viking Residential Sprinkler Installation Guide

**October 25, 2018**



**WARNING:** Cancer and Reproductive Harm-  
[www.P65Warnings.ca.gov](http://www.P65Warnings.ca.gov)

Trusted Above All™

[www.vikinggroupinc.com](http://www.vikinggroupinc.com)



## TECHNICAL DATA

## FREEDOM® RESIDENTIAL SPRINKLER INSTALLATION GUIDE

The Viking Corporation, 210 N Industrial Park Drive, Hastings MI 49058

Telephone: 269-945-9501 Technical Services: 877-384-5464 Fax: 269-818-1680 Email: techsvcs@vikingcorp.com

### 1. DESCRIPTION

Viking residential automatic sprinklers are equipped with a “fast response” heat-sensitive operating element designed to respond individually and quickly to a specific high temperature. Viking residential sprinklers are designed to combine speed of operation with water distribution characteristics to help in the control of residential fires and to improve life safety by prolonging the time available for occupants to escape or be evacuated.

### 2. LISTINGS AND APPROVALS

Refer to the Approval Charts on the appropriate sprinkler technical data page(s) and/or approval agency listings.

- A. Viking residential sprinklers are intended for use in the following occupancies: one- and two-family dwellings and mobile homes with the fire protection sprinkler system installed in accordance with NFPA 13D; residential occupancies up to four stories in height with the fire protection system installed in accordance with NFPA 13R; or residential portions of any occupancy with the fire protection system installed in accordance with NFPA 13. Information contained in this guide is based on NFPA 13, “Standard for the Installation of Sprinkler Systems”.
- B. The design criteria for residential sprinklers contained in the NFPA installation standards must be followed except as modified by the individual UL 1626 listing information provided in the technical data pages and this Residential Sprinkler Installation Guide. For listed areas of coverage, technical data, and specific design and installation instructions, refer to the appropriate Viking technical data page for the sprinkler model used.
- C. Viking residential sprinklers listed by Underwriters Laboratories, Inc. (UL) have passed fire tests designed to represent fire conditions for the sprinkler’s listed area of coverage. The standards for residential sprinkler performance and spray patterns are printed in Underwriters Laboratories Publication UL 1626, “Standard for Residential Sprinklers for Fire Protection Service”. All listed Viking residential sprinklers meet or exceed UL 1626 performance requirements and spray pattern criteria for their listed areas of coverage.
- D. NFPA standards allow use of residential sprinklers with rates, design areas, areas of coverage, and minimum design pressures other than those specified in the standards when they have been listed for such specific residential installation conditions.

### 3. TECHNICAL DATA

#### Specifications:

Refer to the appropriate sprinkler technical data sheet.

#### Material Standards:

Refer to the appropriate sprinkler technical data sheet.

Viking Technical Data may be found on  
The Viking Corporation’s Web site at  
<http://www.vikinggroupinc.com>.  
The Web site may include a more recent  
edition of this Technical Data Page.

### 4. INSTALLATION

**NOTE: Take care not to over-tighten the sprinkler and/or damage its operating parts!**

**Maximum Torque: 1/2” NPT: 14 ft-lbs. (19.0 N-m)      3/4” NPT: 20 ft-lbs. (27.1 N-m)**

#### A. Care and Handling (also refer to Bulletin - Care and Handling of Sprinklers, Form No. F\_091699.)

Sprinklers must be handled with care and protected from mechanical damage during storage, transport, handling, and after installation.

Store sprinklers in a cool, dry place in their original container.

Use care when locating sprinklers near fixtures that can generate heat.

Never install sprinklers that have been dropped, damaged in any way, or exposed to temperatures exceeding the maximum ambient temperature allowed (refer to Table 1.)

Never install any glass-bulb sprinkler if the bulb is cracked or if there is a loss of liquid from the bulb. A small air bubble should be present in the glass bulb. Any sprinkler with a loss of liquid from the glass bulb or damage to the fusible element should be destroyed immediately. (Note: Installing glass bulb sprinklers in direct sunlight (ultraviolet light) may affect the color of the dye used to color code the bulb. This color change does not affect the integrity of the bulb.)

Viking residential sprinklers are intended for use on wet pipe residential systems only. Adequate heat must be provided for wet-pipe systems. DO NOT use Viking residential sprinklers on dry systems unless specifically allowed by recognized installation standards or the Authority Having Jurisdiction.

#### Residential concealed sprinklers must be installed in neutral or negative pressure plenums only!

Corrosion-resistant sprinklers must be installed when subject to corrosive atmospheres. **NOTE:** Viking residential sprinklers are not intended for use in corrosive environments.

Replaces pages 1-17, dated December 1, 2016.

(Added P65 Warning.)



## TECHNICAL DATA

## FREEDOM® RESIDENTIAL SPRINKLER INSTALLATION GUIDE

The Viking Corporation, 210 N Industrial Park Drive, Hastings MI 49058  
 Telephone: 269-945-9501 Technical Services: 877-384-5464 Fax: 269-818-1680 Email: techsvcs@vikingcorp.com

**TABLE 1: RESIDENTIAL SPRINKLER TEMPERATURE RATINGS**

Sprinkler Temperature Classification	Sprinkler Nominal Temperature Rating <sup>1</sup>	Maximum Ambient Ceiling Temperature <sup>3</sup>	Bulb Color
<b>Residential Glass Bulb Style Sprinklers</b>			
Ordinary	155 °F (68 °C)	100 °F (38 °C)	Red
Intermediate	175 °F (79 °C)	150 °F (65 °C)	Yellow
Sprinkler Temperature Classification	Sprinkler Nominal Temperature Rating (Fusing Point) <sup>1</sup>	Maximum Ambient Ceiling Temperature <sup>3</sup>	
<b>Residential Fusible Element Style Sprinklers</b>			
Ordinary	165 °F (74 °C)	100 °F (38 °C)	
Sprinkler Temperature Classification	Sprinkler Nominal Temperature Rating (Fusing Point)	Maximum Ambient Ceiling Temperature <sup>3</sup>	Temperature Identification Stamp
<b>Residential Flush Style Sprinklers</b>			
Ordinary	165 °F (74 °C)	100 °F (38 °C)	On Cover or Sprinkler Inlet (VK476)
Intermediate	220 °F (104 °C)	150 °F (65 °C)	On Cover
Sprinkler Temperature Classification	Sprinkler Nominal Temperature Rating (Fusing Point)	Maximum Ambient Ceiling Temperature <sup>3</sup>	Cover Plate Temperature Rating
<b>Residential Concealed Style Sprinklers</b>			
Ordinary	135 °F (57 °C) <sup>1</sup> , 140 °F (60 °C) <sup>2</sup> , 155 °F (68 °C) <sup>1</sup> , or 165 °F (74 °C) <sup>1</sup>	100 °F (38 °C)	135 °F (57 °C)

### Footnotes

<sup>1</sup> The sprinkler temperature rating is stamped on the deflector or flow shaper.

<sup>2</sup> The temperature rating is stamped on the sprinkler.

<sup>3</sup> Based on NFPA-13. Other limits may apply, depending on fire loading, sprinkler location, and other requirements of the Authority Having Jurisdiction. Refer to specific installation standards.

### B. Installation Instructions

Viking sprinklers are manufactured and tested to meet the rigid requirements of approving agencies. They are designed to be installed in accordance with recognized installation standards NFPA 13, NFPA 13R, and NFPA 13D, and any associated TIAs.

Deviation from the standards or any alteration to the sprinklers or cover plate assemblies after they leave the factory including, but not limited to: painting, plating, coating, or modification, may render the sprinklers inoperative and will automatically nullify the approval and any guarantee made by Viking.

The use of residential sprinklers may be limited due to occupancy and hazard. Residential fire protection systems must be designed and installed only by those who are completely familiar with the appropriate standards and codes, and thoroughly experienced in fire protection design, hydraulic calculations, and sprinkler system installation.

Before installation, be sure to have the appropriate sprinkler model and style, with the correct K-Factor, temperature rating, and response characteristics. Viking residential sprinklers must be installed after the piping is in place to prevent mechanical damage. Keep sprinklers with protective caps or bulb shields contained within the caps or shields during installation and testing, and any time the sprinkler is shipped or handled.

1a. For frame-style sprinklers, install escutcheon (if used), which is designed to thread onto the external threads of the sprinkler\*.

\*Refer to the appropriate sprinkler technical data page to determine approved escutcheons for use with specific sprinkler models.

1b. For flush and concealed style sprinklers: Cut the sprinkler nipple so that the ½" or ¾" (15 mm or 20 mm) NPT\*\* outlet of the reducing coupling is at the desired location and centered in the opening\*\* in the ceiling or wall.

\*\*Size depends on the sprinkler model used. Refer to appropriate sprinkler data page.



## TECHNICAL DATA

## FREEDOM® RESIDENTIAL SPRINKLER INSTALLATION GUIDE

The Viking Corporation, 210 N Industrial Park Drive, Hastings MI 49058

Telephone: 269-945-9501 Technical Services: 877-384-5464 Fax: 269-818-1680 Email: techsvcs@vikingcorp.com

### DESIGN CRITERIA

**For Systems Designed to NFPA 13D or NFPA 13R:** Apply the listed areas of coverage and minimum water supply requirements shown in the approval charts on the residential sprinkler data pages. The sprinkler flow rate is the minimum required discharge from each of the total number of design sprinklers as specified in NFPA 13D or NFPA 13R.

**For Systems Designed to the latest edition of NFPA 13:** The number of design sprinklers is to be the four most hydraulically demanding sprinklers. The minimum required discharge from each of the four sprinklers is to be the greater of the following:

- The flow rates given in the approval charts on the data pages for NFPA 13D and NFPA13R for each area of coverage listed, or
- Calculated based on a minimum discharge of 0.1 gpm/sq. ft. over the “design area” in accordance with sections 8.5.2.1 or 8.6.2.1.2 of NFPA 13. The greatest dimension of the coverage area cannot be any greater than the maximum areas of coverage shown on the data pages.

#### Flow Rates

All residential sprinklers manufactured on or after July 12, 2002 are listed with a single minimum flow rate. Where rooms have more than one sprinkler, multiple-sprinkler calculations are still required, but the first sprinkler and any additional sprinkler or sprinklers must be calculated flowing at identical minimum flow rates, based on the area of sprinkler coverage, using the minimum flow and pressure listed for the sprinkler model used.

Consult the appropriate standards and the Authorities Having Jurisdiction to determine the number of sprinklers to hydraulically calculate to verify adequate water supply for multiple-sprinkler operation.

Operating Pressure: The minimum operating pressure of any sprinkler shall be the minimum operating pressure specified by the listing, or 7 psi (0.5 bar), whichever is greater. The maximum allowable operating pressure is 175 psi (12 bar).

#### Areas of Coverage

If the actual area of coverage is less than the listed area of coverage, use the minimum water supply for the next larger area of coverage listed. DO NOT interpolate. Residential sprinkler systems must be hydraulically calculated according to NFPA standards to verify that the water supply is adequate for proper operation of the sprinklers. Hydraulic calculations are required to verify adequate water supply at the hydraulically most remote single sprinkler when it is operating at the minimum gpm and psi listed for single-sprinkler operation for the sprinkler model used.

Viking residential sprinklers may be listed for more than one area of coverage. Suggested practice in selecting area of coverage is to select the one that can be adequately supplied by the available water supply and still allow for the installation of as few sprinklers in a compartment as possible while observing all guidelines pertaining to obstructions and spacing. This maximizes the use of the available water supply, which is often limited on residential fire protection systems. After selecting an appropriate area of coverage, sprinklers must be spaced according to guidelines set forth in the installation standards.

**Definition of “COMPARTMENT”:** A space completely enclosed by walls and a ceiling. Openings to an adjoining space are allowed, provided the openings have a minimum lintel depth of 8 in. (203.2 mm) from the ceiling.

#### Spacing Guidelines

For guidelines concerning spacing of Viking residential sprinklers near beams, obstructions, heat sources, and sloped ceilings [slopes more than a 2/12 (9.5°) pitch], refer to the Viking residential sprinkler data pages and installation guide, the appropriate NFPA standard, and the Authority Having Jurisdiction. NOTE: Sloped, beamed, and pitched ceilings could require special design features such as larger flow, or a design for more sprinklers to operate in the compartment, or both.

**Distance from Walls:** Install not more than one-half the listed sprinkler spacing nor less than 4” (102 mm) from walls, partitions, or obstructions as defined in the standards.

**Minimum Sprinkler Spacing:** The minimum distance between residential sprinklers to prevent cold soldering (i.e., the spray from one operating sprinkler onto an adjacent sprinkler that could prevent its proper activation) is 8 ft. (2.4 m).

**Maximum Sprinkler Spacing:** Locate adjacent sprinklers no farther apart than the listed spacing.

**Deflector Position:** Install frame style residential *pendent* sprinklers with the deflector between 1” and 4” (25.4 mm to 102 mm) below smooth ceilings, unless the sprinkler data page indicates otherwise. Install pendent sprinklers in the pendent position only, with the deflector oriented parallel with the ceiling or roof.

Refer to the individual listings in the residential sprinkler data pages for horizontal sidewall sprinkler deflector or sprinkler centerline distance below the ceiling. Install horizontal sidewall sprinklers in the horizontal position only below smooth ceilings, with the leading edge of the deflector or element assembly oriented parallel with the ceiling.

**IMPORTANT: Always refer to Bulletin Form No. F\_091699 - Care and Handling of Sprinklers. Also refer to the appropriate sprinkler data page. Viking sprinklers are to be installed in accordance with the latest edition of Viking technical data, the appropriate standards of NFPA and any other similar Authorities Having Jurisdiction, and also with the provisions of governmental codes, ordinances, and standards, whenever applicable. Final approval and acceptance of all residential sprinkler installations must be obtained from the Authorities Having Jurisdiction.**



## TECHNICAL DATA

## FREEDOM® RESIDENTIAL SPRINKLER INSTALLATION GUIDE

The Viking Corporation, 210 N Industrial Park Drive, Hastings MI 49058

Telephone: 269-945-9501 Technical Services: 877-384-5464 Fax: 269-818-1680 Email: techsvcs@vikingcorp.com

2. Apply a small amount of pipe-joint compound or tape to the external threads of the sprinkler only, taking care not to allow a build-up of compound in the sprinkler inlet. **NOTE:** Sprinklers with protective caps or bulb shields must be contained within the caps or shields before applying pipe-joint compound or tape. *Exception: For concealed sprinklers (i.e., VK457, VK458, VK468, VK474, and VK4570) the protective cap is removed for installation.*
3. Care must be taken when installing sprinklers on CPVC and copper piping systems. Never install the sprinkler into the reducing fitting before attaching the reducing fitting to the piping. Sprinklers must be installed on CPVC systems after the reducing fitting has been installed and the primer and/or cement manufacturer's recommended curing time has elapsed. When installing sprinklers on copper piping systems, take care to brush the inside of the sprinkler supply piping and reducing fitting to ensure that no flux accumulates in the sprinkler orifice. Excess flux can cause corrosion and may impair the ability of the sprinkler to operate properly.
4. Refer to the appropriate sprinkler technical data page to determine the correct sprinkler wrench for the model of sprinkler used. DO NOT use the sprinkler deflector or fusible element to start or thread the sprinkler into a fitting.
  - a. Install the sprinkler onto the piping using the special sprinkler wrench only, while taking care not to over-tighten or damage the sprinkler operating parts.
  - b. Thread the flush or concealed sprinkler into the 1/2" or 3/4" (15 mm or 20 mm) NPT\*\* outlet of the coupling by turning it clockwise with the special sprinkler wrench. *NOTE: For flush and concealed sprinklers with protective shells, the internal diameter of the special flush and concealed sprinkler installation wrench is designed for use with the sprinkler contained within the shell. Exception: For concealed sprinklers VK457, VK458, VK468, VK474, and VK4570 the protective cap is removed for installation, and then placed back on the sprinkler temporarily.*
5. After installation, the entire sprinkler system must be tested. The test must be conducted to comply with the installation standards.
  - a. Make sure the sprinkler has been properly tightened. If a thread leak occurs, normally the unit must be removed, new pipe-joint compound or tape applied, and then reinstalled. This is due to the fact that when the joint seal leaks, the sealing compound is washed out of the joint.
  - b. **Remove plastic protective sprinkler caps or bulb shields AFTER the wall or ceiling finish work is completed where the sprinkler is installed and there no longer is a potential for mechanical damage to the sprinkler operating elements.** To remove the bulb shields, simply pull the ends of the shields apart where they are snapped together. To remove caps from frame style sprinklers, turn the caps slightly and pull them off the sprinklers. **SPRINKLER CAPS OR BULB SHIELDS MUST BE REMOVED FROM SPRINKLERS BEFORE PLACING THE SYSTEM IN SERVICE!** Retain a protective cap or shield in the spare sprinkler cabinet.
6. For residential flush sprinklers, the ceiling ring can now be installed onto the sprinkler body. Align the ceiling ring with the sprinkler body and thread on or push it on until the flange touches the ceiling. Note the maximum vertical adjustment is 1/2" (12,7 mm) for sprinkler VK420 and 5/8" for VK476. DO NOT MODIFY THE UNIT. If necessary, re-cut the sprinkler drop nipples as required.
7. For residential concealed sprinklers, the cover plate assembly can now be attached.
  - a. Remove the cover plate assembly from the protective box, taking care not to damage the assembly.
  - b. From below the ceiling, gently place the base of the cover plate assembly over the sprinkler protruding through the opening in the ceiling or wall.
  - c. Carefully push the cover plate assembly onto the sprinkler, using even pressure with the palm of the hand, until the unfinished brass flange of the cover plate base touches the ceiling or wall.
  - d. The maximum adjustment available for residential concealed sprinklers is 1/2" (12.7 mm) [1/4" (6.4 mm) for sprinkler VK480]. DO NOT MODIFY THE UNIT. If necessary, re-cut the sprinkler nipples.

**NOTE:** If it is necessary to remove the entire sprinkler unit, the system must be taken out of service. See Maintenance instructions below and follow all warnings and instructions.

## 5. OPERATION

During fire conditions, the operating element fuses or shatters (depending on the type of sprinkler), releasing the pip cap and sealing assembly. Water flowing through the sprinkler orifice strikes the sprinkler deflector or flow shaper, forming a uniform, high-wall wetting spray pattern to extinguish or control the fire.



## TECHNICAL DATA

## FREEDOM® RESIDENTIAL SPRINKLER INSTALLATION GUIDE

The Viking Corporation, 210 N Industrial Park Drive, Hastings MI 49058

Telephone: 269-945-9501 Technical Services: 877-384-5464 Fax: 269-818-1680 Email: techsvcs@vikingcorp.com

### 6. INSPECTIONS, TESTS AND MAINTENANCE

Refer to NFPA 25 for Inspection, Testing and Maintenance requirements. **NOTICE:** The owner is responsible for having the fire-protection system and devices inspected, tested, and maintained in proper operating condition in accordance with this guide, and applicable NFPA standards. In addition, the Authority Having Jurisdiction may have additional maintenance, testing, and inspection requirements that must be followed.

- A. Sprinklers must be inspected on a regular basis for signs of corrosion, mechanical damage, obstructions, paint, etc. Frequency of the inspections may vary due to corrosive atmospheres, water supplies, and activity around the device.
- B. Sprinklers or cover plate assemblies that have been field painted, caulked, or mechanically damaged must be replaced immediately. Sprinklers showing signs of corrosion shall be tested and/or replaced immediately as required. Installation standards require sprinklers to be tested and, if necessary, replaced immediately after a specified term of service. Refer to NFPA 25 and the Authorities Having Jurisdiction for the specified period of time after which testing and/or replacement of residential sprinklers is required. Never attempt to repair or reassemble a sprinkler. Sprinklers and cover assemblies that have operated cannot be reassembled or re-used, but must be replaced. When replacement is necessary, use only new sprinklers and cover assemblies with identical performance characteristics.
- C. The sprinkler discharge pattern is critical for proper fire protection. Nothing should be hung from, attached to, or otherwise obstruct the discharge pattern of the sprinkler. All obstructions must be immediately removed or, if necessary, additional sprinklers installed.
- D. When replacing existing sprinklers, the system must be removed from service. Refer to the appropriate system description and/or valve instructions. Prior to removing the system from service, notify all Authorities Having Jurisdiction. Consideration should be given to employment of a fire patrol in the effected area.
  1. Remove the system from service, drain all water, and relieve all pressure on the piping.
  - 2a. For frame-style sprinklers, use the special sprinkler wrench and remove the old sprinkler by turning it counterclockwise to unthread it from the piping.
  - 2b. *For residential flush pendent and concealed style sprinklers: Remove the ceiling ring or cover plate assembly before unthreading the sprinkler body from the piping. To remove a ceiling ring, grasp it from below the ceiling and gently turn it counterclockwise. Cover plates can be removed either by gently unthreading them or pulling them off the sprinkler body (depends on the sprinkler model used). After the ceiling ring or cover plate assembly has been removed from the sprinkler, use the sprinkler wrench to unthread the sprinkler from the piping. NOTE: For flush and concealed sprinklers with protective shells, the internal diameter of the special flush and concealed sprinkler installation wrench is designed for use with the sprinkler contained within the shell. Place a plastic protective shell (from the spare sprinkler cabinet) over the sprinkler to be removed and then fit the sprinkler wrench over the shell. Exception: Concealed sprinklers VK457, VK458, VK468, VK474, and VK4570 are removed without the plastic cap.*
  3. Follow instructions in section 4B. Installation Instructions to install the new unit. Be sure the replacement sprinkler is the correct model and style, with the appropriate K-Factor, temperature rating, and response characteristics. A fully stocked sprinkler cabinet should be provided for this purpose. *(For flush or concealed style sprinklers, stock of spare ceiling rings or cover plates should also be available in the spare sprinkler cabinet.)*
  4. Place the system back in service and secure all valves. Check for and repair all leaks.
- E. Sprinkler systems that have been subjected to a fire must be returned to service as soon as possible. The entire system must be inspected for damage, and repaired or replaced as necessary. Sprinklers that have been exposed to corrosive products of combustion or high ambient temperatures, but have not operated, should be replaced. Refer to the Authority Having Jurisdiction for minimum replacement requirements.

### 7. AVAILABILITY

Viking Residential Sprinklers are available through a network of domestic and international distributors. See The Viking Corporation web site for the closest distributor or contact The Viking Corporation.

### 8. GUARANTEE

For details of warranty, refer to Viking's current list price schedule or contact Viking directly.

<h1>VIKING</h1>	<h2>TECHNICAL DATA</h2>	<h3>FREEDOM® RESIDENTIAL SPRINKLER INSTALLATION GUIDE</h3>
-----------------	-------------------------	--

The Viking Corporation, 210 N Industrial Park Drive, Hastings MI 49058  
 Telephone: 269-945-9501 Technical Services: 877-384-5464 Fax: 269-818-1680 Email: techsvcs@vikingcorp.com

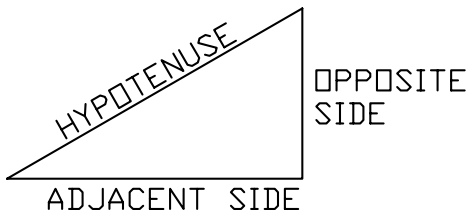

TANGENT =  
 OPPOSITE SIDE (RISE)  
 ADJACENT SIDE (RUN)

$$\frac{\text{RISE}}{\text{RUN}} = \text{TANGENT}$$

$$\text{ANGLE} = \text{TAN}^{-1} \left( \frac{\text{RISE}}{\text{RUN}} \right)$$

$$\text{SLOPE DISTANCE} = \sqrt{(\text{RISE})^2 + (\text{RUN})^2}$$

RISE	RUN	TANGENT	ANGLE	SLOPE DISTANCE
2	12	.1666	9.45°	12.1
3	12	.2500	14°	12.3
4	12	.3333	18.4°	12.6
5	12	.4166	22.6°	13
6	12	.5000	26.5°	13.4
7	12	.5833	30.2°	13.8
8	12	.6666	33.6°	14.4
9	12	.7500	36.8°	15
10	12	.8333	39.8°	15.6
11	12	.9166	42.5°	16.2
12	12	1	45°	16.97

**Table 2**  
 Rise Over Run Conversion to Degrees of Slope

	<b>TECHNICAL DATA</b>	<b>FREEDOM® RESIDENTIAL SPRINKLER INSTALLATION GUIDE</b>
---	-----------------------	--

The Viking Corporation, 210 N Industrial Park Drive, Hastings MI 49058  
 Telephone: 269-945-9501 Technical Services: 877-384-5464 Fax: 269-818-1680 Email: techsvcs@vikingcorp.com

**SPACING OF RESIDENTIAL SPRINKLERS LISTED FOR USE  
BELOW SLOPED CEILINGS UP TO AN 8/12 (33.7°) PITCH**  
 (Refer to the appropriate residential sprinkler technical data page for listings.)

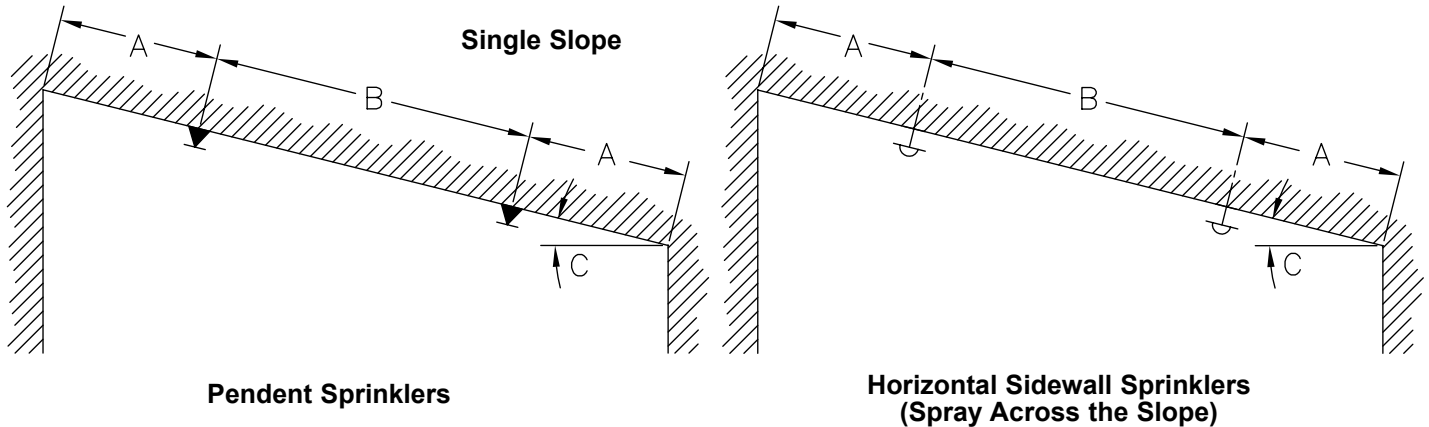

**Figure 1**

- (A) One-half listed spacing of sprinkler maximum, 0'-4" (0-102 mm) minimum.
- (B) Listed spacing of sprinkler, maximum, 8'-0" (2.4 m) minimum.
- (C) Where angle "C" is greater than an 8/12 (33.7°) pitch, see Figure 2 below.

**SPACING OF RESIDENTIAL SPRINKLERS BELOW SLOPED  
CEILINGS WITH GREATER THAN 8/12 (33.7°) PITCH**  
 (NOTE: Refer to NFPA 13D or NFPA 13R, and the Authority Having Jurisdiction.)

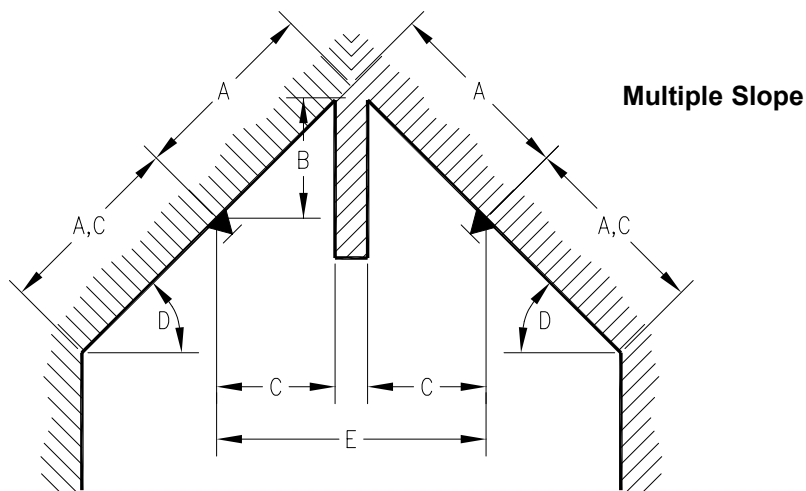

**Figure 2**

- (A) One-half listed spacing of sprinkler, maximum.
- (B) 3'-0" (.91 m) maximum.
- (C) 0'-4" (0-102 mm) minimum.
- (D) Slopes greater than an 8/12 (33.7°) pitch.
- (E) For distance less than 8'-0" (2.4 m), baffle required.





## TECHNICAL DATA

## FREEDOM® RESIDENTIAL SPRINKLER INSTALLATION GUIDE

The Viking Corporation, 210 N Industrial Park Drive, Hastings MI 49058  
 Telephone: 269-945-9501 Technical Services: 877-384-5464 Fax: 269-818-1680 Email: techsvcs@vikingcorp.com

### SPACING OF RESIDENTIAL SPRINKLERS LISTED FOR USE BELOW SLOPED CEILINGS UP TO AN 8/12 (33.7°) PITCH

(Refer to the appropriate residential sprinkler technical data page for listings.)

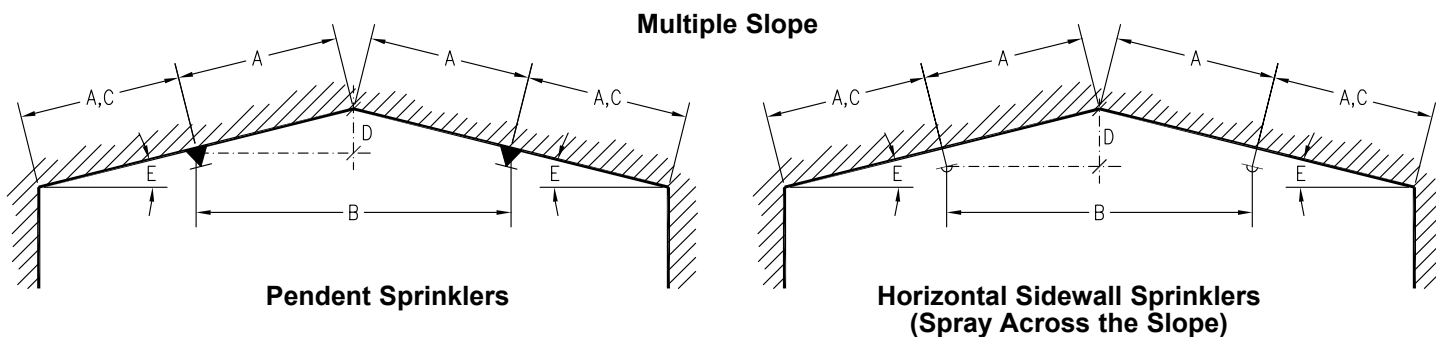
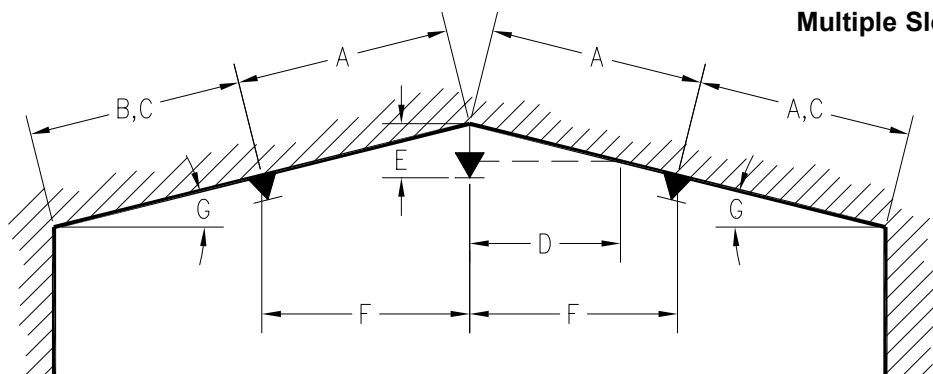

**Figure 3**

- (A) One-half listed spacing of sprinkler, maximum.
- (B) 8'-0" (2.4 m) minimum.
- (C) 0'-4" (0-102 mm) minimum.
- (D) 3'-0" (.91 m) maximum.
- (E) Acceptable for slopes of 0/12 to 8/12 (0° to 33.7°) pitch.

### SPACING OF RESIDENTIAL PENDENT SPRINKLERS AT PEAK OF SLOPED CEILINGS WITH PITCH LESS THAN 8/12 (33.7°)

(Refer to the appropriate residential sprinkler technical data page for listings.)



**Figure 4**

- (A) Listed spacing of sprinkler, maximum.
- (B) One-half listed spacing of sprinkler, maximum.
- (C) 0'-4" minimum.
- (D) Refer to page 10 for minimum distance between sprinkler and intersecting sloped ceiling.
- (E) Refer to the appropriate residential sprinkler technical data page for deflector distance below ceiling.
- (F) 8'-0" minimum.
- (G) Reference: 4/12 (18.0°) pitch maximum for 12' (3.7 m) spacing.  
 2.5/12 (12.0°) pitch maximum for 14' (4.3 m) spacing.  
 2/12 (10.0°) pitch maximum for 16' (4.9 m) spacing.  
 2/12 (10.0°) pitch maximum for 18' (5.5 m) spacing.  
 1.9/12 (9.0°) pitch maximum for 20' (6.1 m) spacing.  
 Angles based on sprinklers installed 0'-4" (0-102 mm) from peak.

**NOTE:** Whenever possible, utilize design as shown in Figure 3 above.



**TECHNICAL DATA**

**FREEDOM® RESIDENTIAL  
SPRINKLER  
INSTALLATION GUIDE**

The Viking Corporation, 210 N Industrial Park Drive, Hastings MI 49058

Telephone: 269-945-9501 Technical Services: 877-384-5464 Fax: 269-818-1680 Email: techsvcs@vikingcorp.com

**SPACING OF RESIDENTIAL SPRINKLERS BELOW SLOPED CEILINGS WITH GREATER THAN 8/12 (33.7°) PITCH WITH NO BAFFLE AND A MAXIMUM OF 2 SPRINKLERS IN THE ROOM**  
(NOTE: Refer to NFPA 13D or NFPA 13R, and the Authority Having Jurisdiction.)

**Multiple Slope**

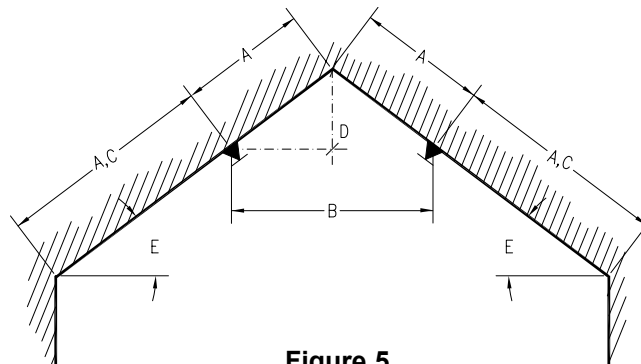
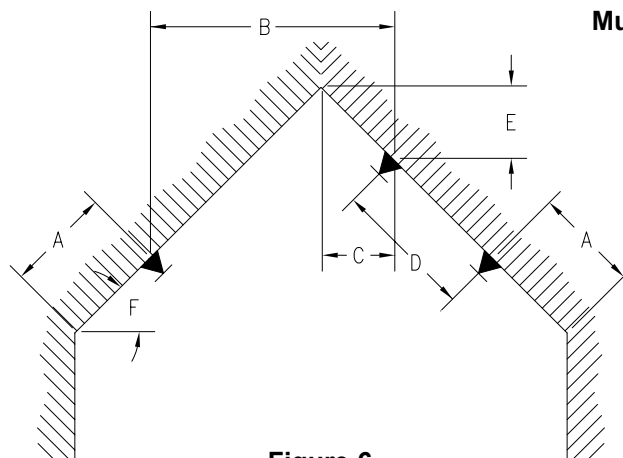

**Figure 5**

- (A) One-half listed spacing of sprinkler, maximum.
- (B) 8'-0" (2.4 m) minimum.
- (C) 0'-4" (0-102 mm) minimum.
- (D) 3'-0" (.91 m) maximum.
- (E) Acceptable for slopes greater than an 8/12 (33.7°) pitch.
- (F) When this design is used, refer to the appendices of NFPA 13D or NFPA 13R, and the Authority Having Jurisdiction regarding the number of design sprinklers to hydraulically calculate.

**SPACING OF RESIDENTIAL SPRINKLERS BELOW CEILINGS WITH SLOPES EXCEEDING 8/12 (33.7°) PITCH WITH NO BAFFLE AND A MAXIMUM OF 3 SPRINKLERS IN THE ROOM**  
(NOTE: Refer to NFPA 13D or NFPA 13R, and the Authority Having Jurisdiction.)

**Multiple Slope**



**Figure 6**

- (A) 0'-4" (0-102 mm) minimum, to one-half listed spacing, maximum.
- (B) One-half listed spacing, maximum, 8'-0" (2.4 m) minimum.
- (C) 0'-4" (0-102 mm) minimum.
- (D) Listed spacing maximum, 8'-0" (2.4 m) minimum.
- (E) 3'-0" (.91 m) maximum.
- (F) Slopes greater than 8/12 up to a 21/12 (33.7° up to 60°) pitch.

**NOTES:** In addition to the above limits, rooms requiring this type of installation must be hydraulically calculated to supply a minimum of three operating sprinklers. Layout similar for horizontal sidewall sprinklers with throw across slope. Refer to the appropriate residential sprinkler technical data sheets.



TECHNICAL DATA

FREEDOM® RESIDENTIAL  
SPRINKLER  
INSTALLATION GUIDE

The Viking Corporation, 210 N Industrial Park Drive, Hastings MI 49058  
Telephone: 269-945-9501 Technical Services: 877-384-5464 Fax: 269-818-1680 Email: techsvcs@vikingcorp.com

**SPACING OF RESIDENTIAL SPRINKLERS BELOW CEILINGS WITH SLOPES EXCEEDING 8/12 (33.7°) PITCH WITH NO BAFFLE AND A MAXIMUM OF 2 SPRINKLERS IN THE ROOM**  
(NOTE: Refer to NFPA 13D or NFPA 13R, and the Authority Having Jurisdiction.)

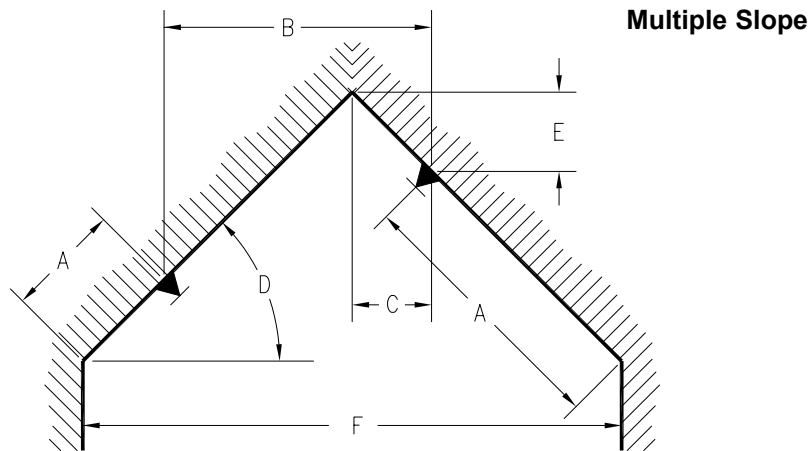

**Figure 7**

- (A) 0'-4" (0-102 mm) minimum, to one-half listed spacing, maximum.
- (B) One-half listed spacing, maximum, 8'-0" (2.4 m) minimum.
- (C) 0'-4" (0-102 mm) minimum.
- (D) Slopes greater than 8/12 pitch up to a 21/12 (33.7° up to a 60°) pitch.
- (E) 3'-0" (.91 m) maximum.
- (F) When dimension "F" exceeds 16' (4.9 m), utilize design configuration shown in Figure 6.

**NOTES:** Layout similar for horizontal sidewall sprinklers with throw across slope. Refer to the appropriate residential sprinkler technical data sheets.

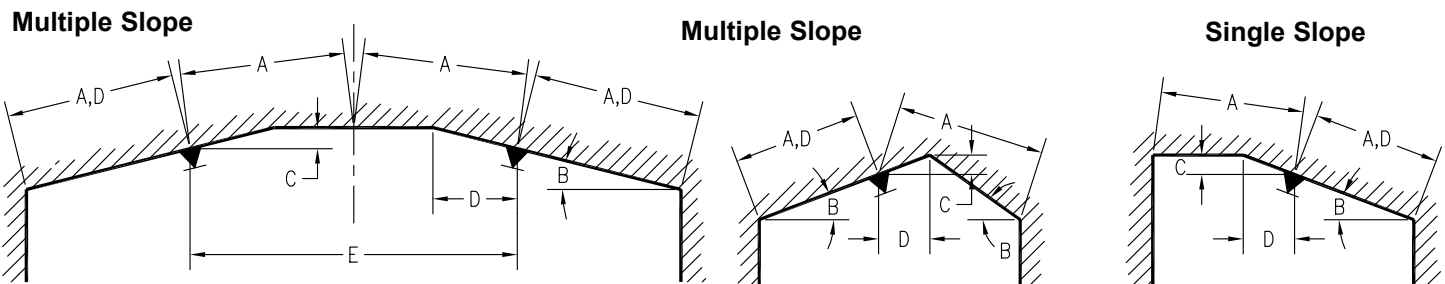

**Figure 8**

- (A) One-half listed spacing, maximum.
- (B) Refer to the appropriate residential sprinkler technical data pages for listings of sprinklers for use below slopes up to and including a 8/12 (33.7°) pitch.
- (C) 3'-0" (.91 m) maximum.
- (D) 0'-4" (0-102 mm) minimum.
- (E) 8'-0" (2.4 m) minimum without baffle.

**NOTES:** Layout similar for horizontal sidewall sprinklers with throw across slope. Refer to the appropriate residential sprinkler technical data sheets.



**TECHNICAL DATA**

**FREEDOM® RESIDENTIAL  
SPRINKLER  
INSTALLATION GUIDE**

The Viking Corporation, 210 N Industrial Park Drive, Hastings MI 49058  
 Telephone: 269-945-9501 Technical Services: 877-384-5464 Fax: 269-818-1680 Email: techsvcs@vikingcorp.com

**MINIMUM DISTANCE BETWEEN SPRINKLER AND INTERSECTING SLOPED CEILINGS**

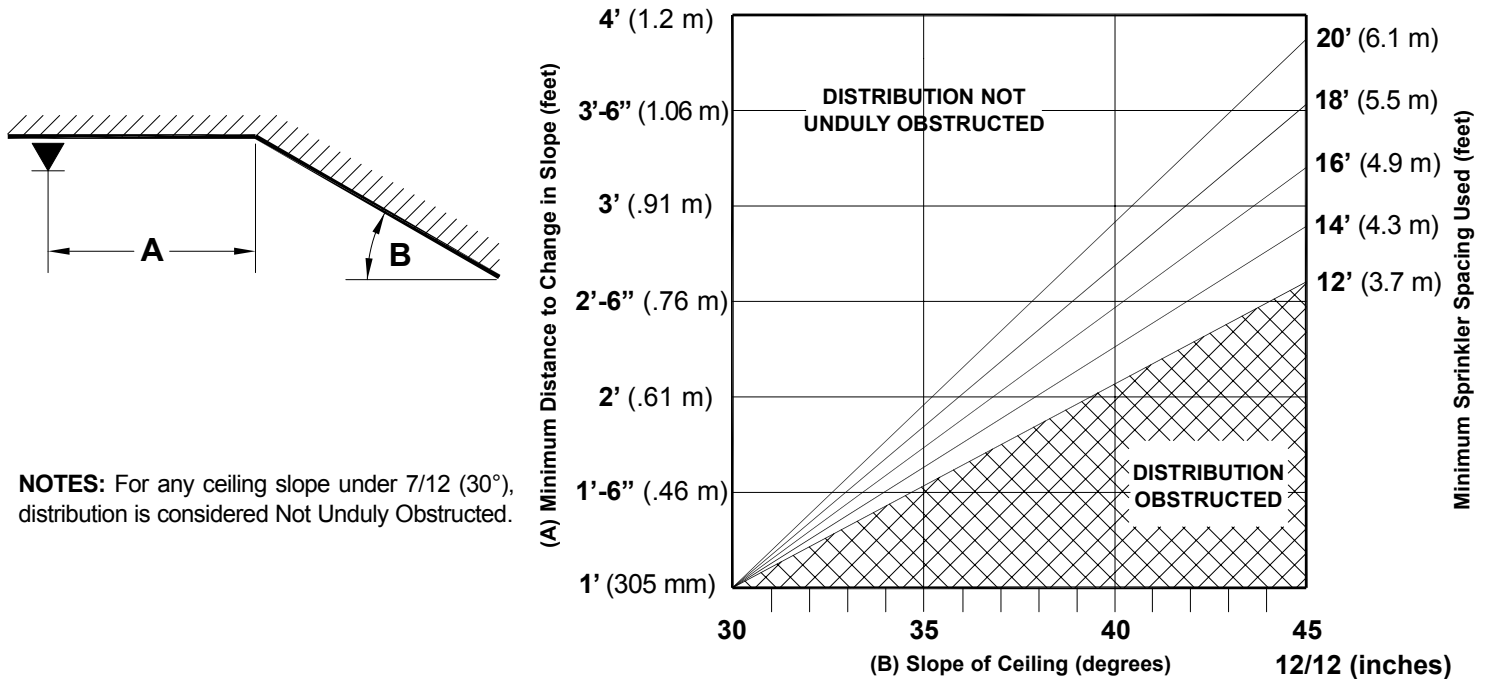

**MAXIMUM DISTANCE DOWN SLOPE TO AVOID OBSTRUCTION TO SPRINKLER DISCHARGE**

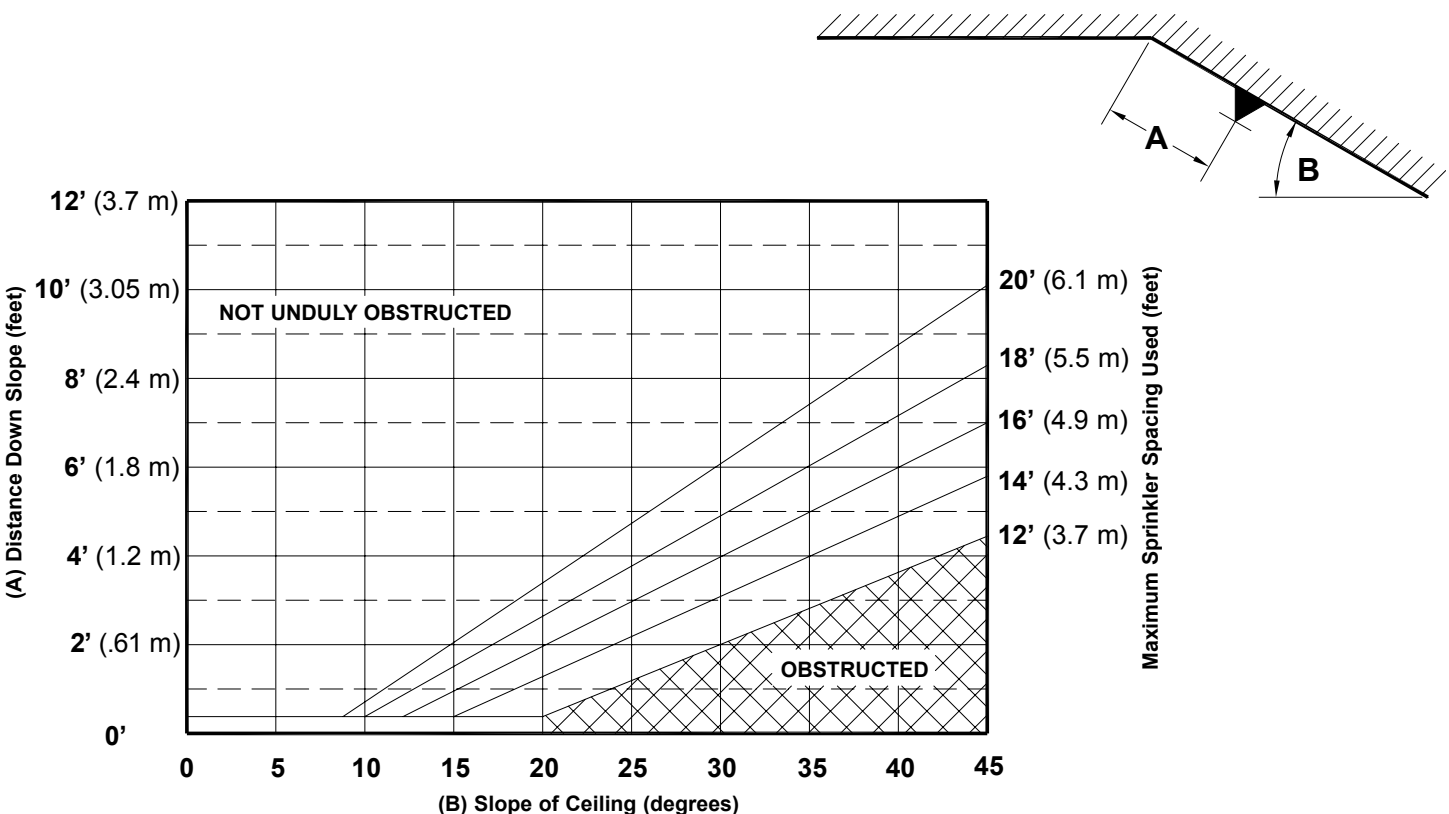



**TECHNICAL DATA**

**FREEDOM® RESIDENTIAL  
SPRINKLER  
INSTALLATION GUIDE**

The Viking Corporation, 210 N Industrial Park Drive, Hastings MI 49058  
 Telephone: 269-945-9501 Technical Services: 877-384-5464 Fax: 269-818-1680 Email: techsvcs@vikingcorp.com

**AVOIDING OBSTRUCTIONS TO SPRINKLER DISCHARGE**  
 (Obstruction rules for residential sprinklers are found in section 8.10 of the 2010 edition of NFPA 13.)  
**Positioning Residential Pendent Sprinklers - Obstructions at the Ceiling**

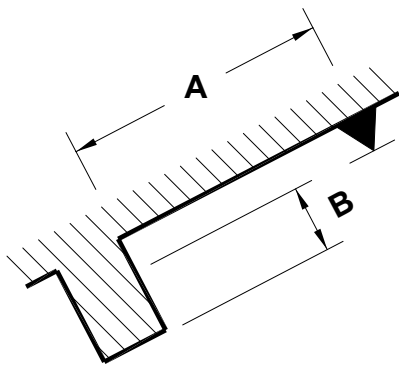
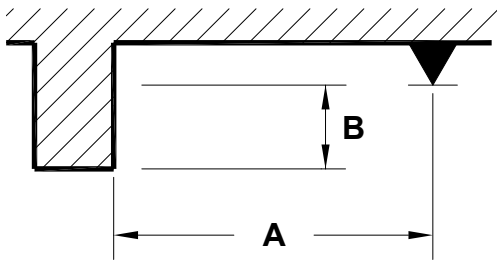

Distance from Sprinkler to Side of Ceiling Obstruction (Dimension A)	Maximum Distance from Deflector to Bottom of Ceiling Obstruction (Dimension B)	
	Inches	mm
Less than 1 ft. 6 in. (Less than 457 mm)	0	0
1 ft. 6 in. to less than 3 ft. (457 mm to less than .94 m)	1	25.4
3 ft. to less than 4 ft. (.91 m to less than 1.2 m)	3	76
4 ft. to less than 4 ft. 6 in. (1.2 m to less than 1.37 m)	5	127
4 ft. 6 in. to less than 6 ft. (1.37 m to less than 1.8 m)	7	178
6 ft. to less than 6 ft. 6 in. (1.8 m to less than 2 m)	9	229
6 ft. 6 in. to less than 7 ft. (2 m to less than 2.1 m)	11	279
7 ft. or greater (2.1 m or greater)	14	356

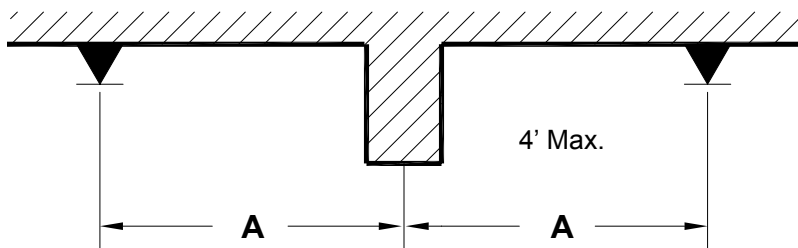

Residential pendent sprinklers may be located on opposite sides of continuous obstructions up to 4 ft. (1.2 m) wide at the ceiling, as long as the distance from the centerline of the obstruction to the sprinklers (A) does not exceed one-half the maximum spacing allowed between sprinklers.

**Positioning Residential Pendent Sprinklers - Obstructions Along Walls**

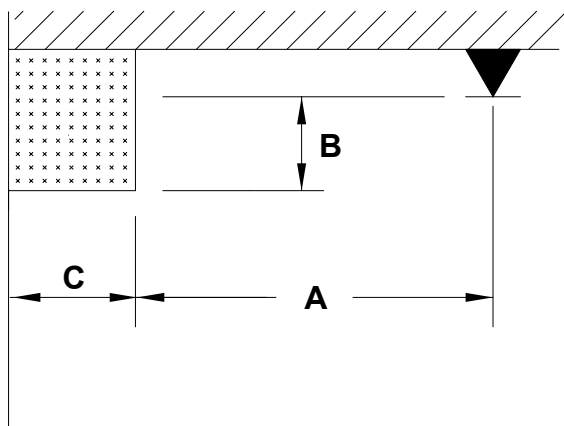

- (A) Distance from centerline of sprinkler to side of obstruction.
- (B) Distance from deflector to bottom of obstruction.
- (C) Width of the obstruction.

Obstructions up to 30 in. (.8 m) wide (C) located against the wall are permitted to be protected when (A) is greater than or equal to (C) minus 8 in. (.2 m) plus (B).

$$C \leq 30 \text{ in.} \quad \text{for metric } C \leq .8 \text{ m}$$

$$A \geq (C - 8 \text{ in.}) + B \quad A \geq (C - .2 \text{ m}) + B$$

	<b>TECHNICAL DATA</b>	<b>FREEDOM® RESIDENTIAL SPRINKLER INSTALLATION GUIDE</b>
---	-----------------------	--

The Viking Corporation, 210 N Industrial Park Drive, Hastings MI 49058  
 Telephone: 269-945-9501 Technical Services: 877-384-5464 Fax: 269-818-1680 Email: techsvcs@vikingcorp.com

**AVOIDING OBSTRUCTIONS TO SPRINKLER DISCHARGE**

(Obstruction rules for residential sprinklers are found in section 8.10 of the 2010 edition of NFPA 13.)

**Positioning Residential Horizontal Sidewall Sprinklers - Obstructions at the Ceiling**

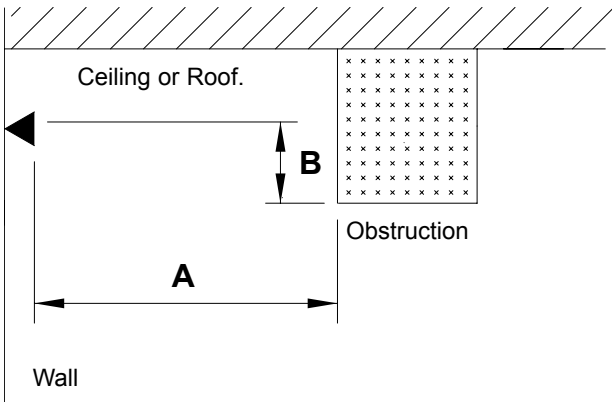

(A) Distance from sprinkler to side of obstruction.  
 (B) Distance from deflector to bottom of obstruction.

Distance from Sprinkler to Side of Ceiling Obstruction (Dimension A)	Maximum Distance from Deflector to Bottom of Ceiling Obstruction (Dimension B)	
	Inches	mm
Less than 8 ft. (Less than 2.4 m)	No Obstructions Allowed	
8 ft. to less than 10 ft. (2.4 m to less than 3.05 m)	1	25.4
10 ft. to less than 11 ft. (3.05 m to less than 3.35 m)	2	50.8
11 ft. to less than 12 ft. (3.35 m to less than 3.7 m)	3	76
12 ft. to less than 13 ft. (3.7 m to less than 4 m)	4	102
13 ft. to less than 14 ft. (4 m to less than 4.3 m)	6	152
14 ft. to less than 15 ft. (4.3 m to less than 4.6 m)	7	178
15 ft. to less than 16 ft. (4.6 m to less than 4.9 m)	9	229
16 ft. to less than 17 ft. (4.9 m to less than 5.2 m)	11	279
17 ft. or greater (5.2 m or greater)	14	356

**Positioning Residential Horizontal Sidewall Sprinklers - Obstructions Along Walls**

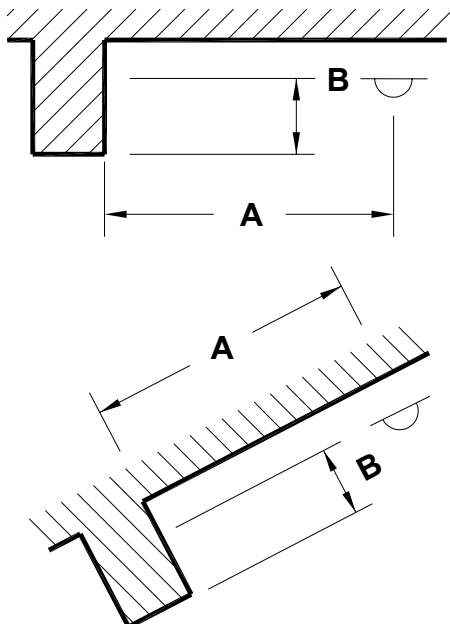

Distance from Sprinkler to Side of Obstruction Along Wall (Dimension A)	Maximum Distance from Deflector to Bottom of Obstruction (Dimension B)	
	Inches	mm
Less than 1 ft. 6 in. (Less than 457 mm)	0	0
1 ft. 6 in. to less than 3 ft. (457 mm to less than .94 m)	1	25.4
3 ft. to less than 4 ft. (.91 m to less than 1.2 m)	3	76
4 ft. to less than 4 ft. 6 in. (1.2 m to less than 1.37 m)	5	127
4 ft. 6 in. to less than 6 ft. (1.37 m to less than 1.8 m)	7	178
6 ft. to less than 6 ft. 6 in. (1.8 m to less than 2 m)	9	229
6 ft. 6 in. to less than 7 ft. (2 m to less than 2.1 m)	11	279
7 ft. or greater (2.1 m or greater)	14	356

(A) Distance from sprinkler to side of obstruction.  
 (B) Distance from deflector to bottom of obstruction.



## TECHNICAL DATA

## FREEDOM® RESIDENTIAL SPRINKLER INSTALLATION GUIDE

The Viking Corporation, 210 N Industrial Park Drive, Hastings MI 49058

Telephone: 269-945-9501 Technical Services: 877-384-5464 Fax: 269-818-1680 Email: techsvcs@vikingcorp.com

### LOCATING RESIDENTIAL SPRINKLERS NEAR HEAT SOURCES

Ordinary temperature rated residential sprinklers (135 °F to 170 °F rated) are only to be installed where the maximum ambient ceiling temperature will not exceed 100 °F. Where the maximum ambient ceiling temperature will be from 101 °F to 150 °F, use intermediate temperature rated residential sprinklers (175 °F to 225 °F rated).

Residential sprinklers must be positioned a sufficient distance away from heat sources that include fireplaces, stoves, kitchen ranges, wall ovens, hot water pipes, water heaters, furnaces and associated flues and ducts, and light fixtures. The following minimum distances must be maintained for both ordinary and intermediate temperature rated residential sprinklers as indicated.

Heat Source	Minimum Distance from Edge of Source to Ordinary Temperature Rated Sprinkler		Minimum Distance from Edge of Source to Intermediate Temperature Rated Sprinkler	
	Inches	metric	Inches	metric
Side of open or recessed fireplace	36	.91 m	12	305 mm
Front of recessed fire place	60	1.5 m	36	.91 m
Coal- or wood-burning stove	42	1.1 m	12	305 mm
Kitchen range	18	457 mm	9	229 mm
Wall oven	18	457 mm	9	229 mm
Hot air flues	18	457 mm	9	229 mm
Uninsulated heat ducts	18	457 mm	9	229 mm
Uninsulated hot water pipes	12	305 mm	6	152 mm
Side of ceiling- or wall-mounted hot air diffusers	24	.61 m	12	305 mm
Front of wall-mounted hot air diffusers	36	.91 m	18	457 mm
Hot water heater or furnace	6	152 mm	3	76 mm
Light fixture less than 250W	6	152 mm	3	76 mm
Light fixture 250W to 499W	12	305 mm	6	152 mm
Where residential sprinklers will be exposed to the rays of the sun passing through glass or plastic skylights, use intermediate temperature rated sprinklers.				
When locating residential sprinklers in an unventilated concealed compartment, under an unventilated attic or uninsulated roof, where the maximum ambient temperature does not exceed 150 °F, use intermediate temperature rated sprinklers.				



**TECHNICAL DATA**

**FREEDOM® RESIDENTIAL  
SPRINKLER  
INSTALLATION GUIDE**

The Viking Corporation, 210 N Industrial Park Drive, Hastings MI 49058

Telephone: 269-945-9501 Technical Services: 877-384-5464 Fax: 269-818-1680 Email: techsvcs@vikingcorp.com

**NOTE:** The dimensions shown are intended to apply to residential sprinklers installed in ceilings above fireplaces used to burn products that cause elevated temperatures at or near the ceiling in areas surrounding the fireplace. The recommendations should not be construed to apply to decorative non-opening fireplaces such as gas fire units that will not cause elevated temperatures at the ceiling.

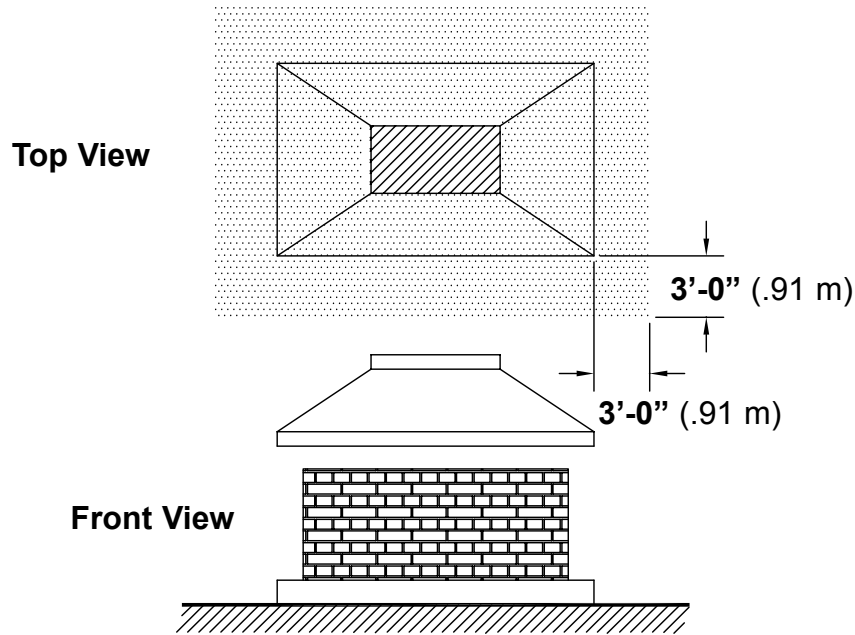

Sprinklers near an open hearth fireplace must be located outside of the shaded area or be intermediate degree rated.

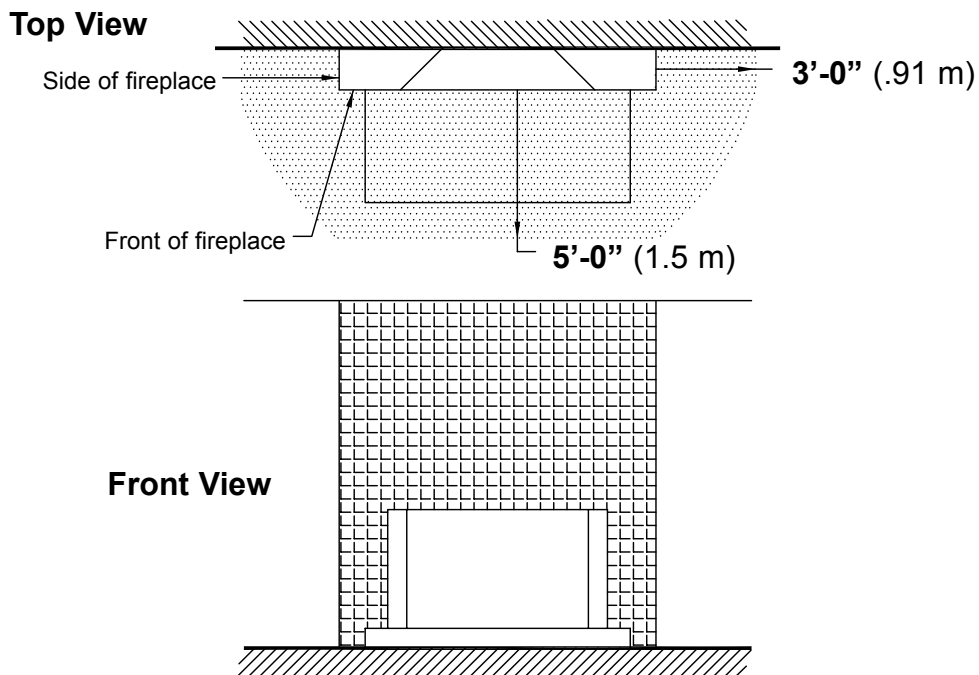

Sprinklers near a recessed hearth fireplace must be located outside of the shaded area [at least 3'-0" (.91 m)] from the side of a recessed fireplace and at least 5'-0" (1.5 m) from the front) or be intermediate degree rated.



	<b>TECHNICAL DATA</b>	<b>FREEDOM® RESIDENTIAL SPRINKLER INSTALLATION GUIDE</b>
---	-----------------------	--

The Viking Corporation, 210 N Industrial Park Drive, Hastings MI 49058  
 Telephone: 269-945-9501 Technical Services: 877-384-5464 Fax: 269-818-1680 Email: techsvcs@vikingcorp.com

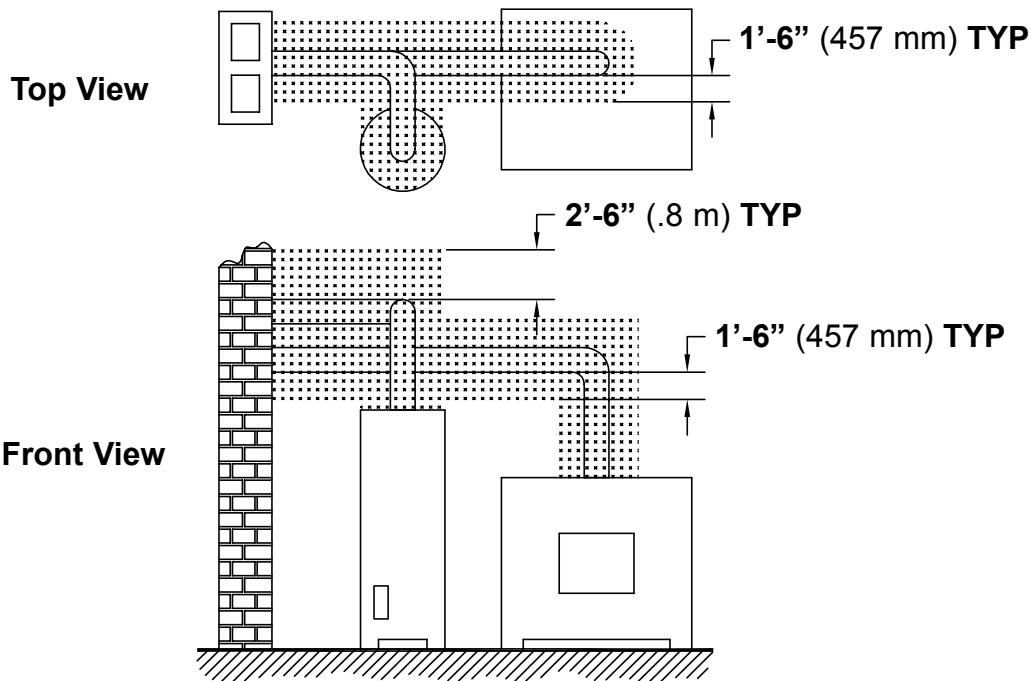

Sprinklers near a furnace or water heater must be located outside of the shaded area or be intermediate degree rated.

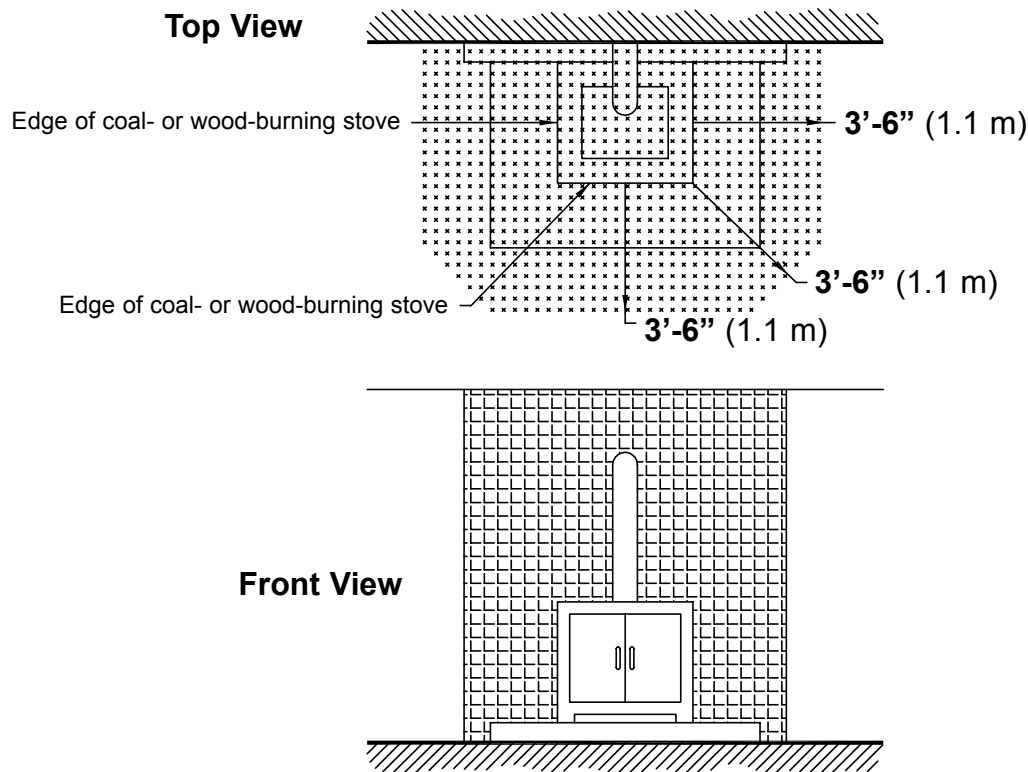

Sprinklers near a coal- or wood-burning stove must be located outside of shaded area or be intermediate degree rated.



TECHNICAL DATA

FREEDOM® RESIDENTIAL  
SPRINKLER  
INSTALLATION GUIDE

The Viking Corporation, 210 N Industrial Park Drive, Hastings MI 49058  
Telephone: 269-945-9501 Technical Services: 877-384-5464 Fax: 269-818-1680 Email: techsvcs@vikingcorp.com

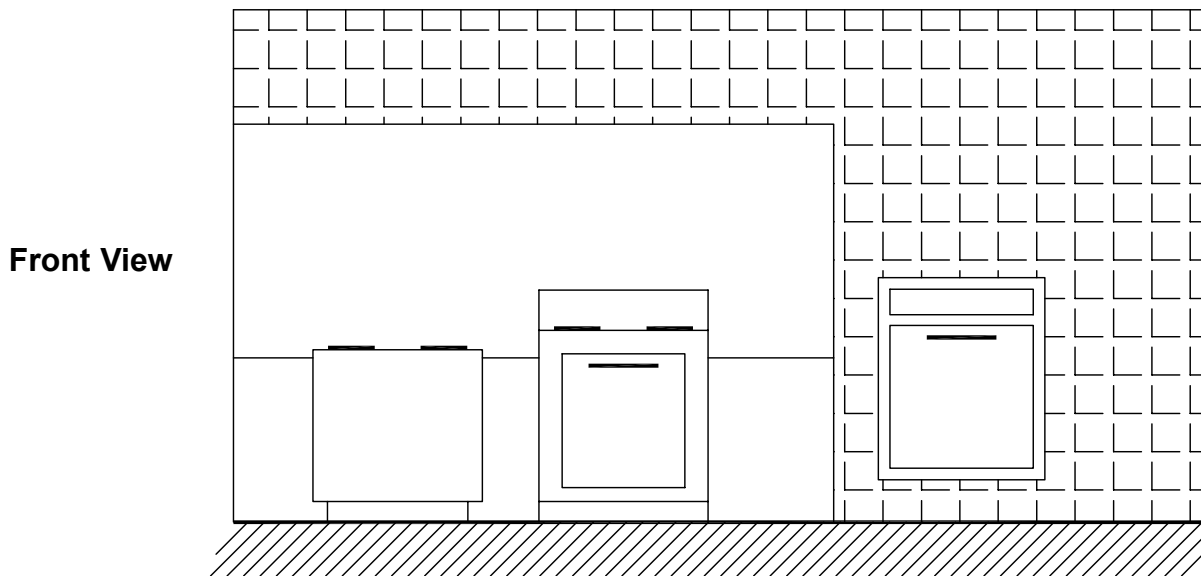
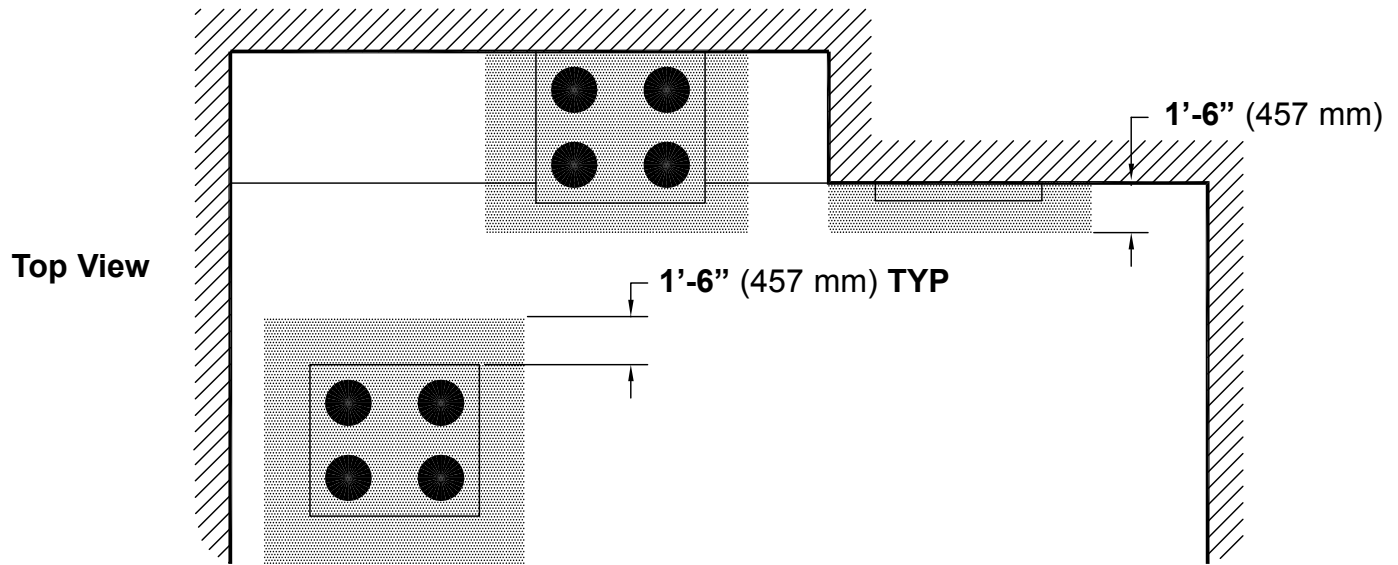

Sprinklers near a range or wall oven must be located outside of shaded areas or be intermediate degree rated.



**BULLETIN**

**CARE AND HANDLING OF SPRINKLERS**

The Viking Corporation, 210 N Industrial Park Drive, Hastings MI 49058  
 Telephone: 269-945-9501 Technical Services: 877-384-5464 Fax: 269-818-1680 Email: techsvcs@vikingcorp.com

**SPRINKLERS ARE FRAGILE - HANDLE WITH CARE!**

**General Handling and Storage:**

- Store sprinklers in a cool, dry place.
- Protect sprinklers during storage, transport, handling, and after installation.
- Use the original shipping containers. DO NOT place sprinklers loose in boxes, bins, or buckets.
- Keep sprinklers separated at all times. DO NOT allow metal parts to contact sprinkler operating elements.

**For Pre-Assembled Drops:**

- Protect sprinklers during handling and after installation.
- For recessed assemblies, use the protective sprinkler cap (Viking Part Number 10364).

**Sprinklers with Protective Shields or Caps:**

- DO NOT remove shields or caps until after sprinkler installation and there no longer is potential for mechanical damage to the sprinkler operating elements.
- **Sprinkler shields or caps MUST be removed BEFORE placing the system in service!**
- Remove the sprinkler shield by carefully pulling it apart where it is snapped together.
- Remove the cap by turning it slightly and pulling it off the sprinkler.

**Sprinkler Installation:**

- DO NOT use the sprinkler deflector or operating element to start or thread the sprinkler into a fitting.
- **Use only the designated sprinkler head wrench!** Refer to the current sprinkler technical data page to determine the correct wrench for the model of sprinkler used.
- DO NOT install sprinklers onto piping at the floor level.
- Install sprinklers after the piping is in place to prevent mechanical damage.
- DO NOT allow impacts such as hammer blows directly to sprinklers or to fittings, pipe, or couplings in close proximity to sprinklers. Sprinklers can be damaged from direct or indirect impacts.
- DO NOT attempt to remove drywall, paint, etc., from sprinklers.
- **Take care not to over-tighten the sprinkler and/or damage its operating parts!**

**Maximum Torque:**

- 1/2" NPT: 14 ft-lbs. (19.0 N-m)**
- 3/4" NPT: 20 ft-lbs. (27.1 N-m)**
- 1" NPT: 30 ft-lbs. (40.7 N-m)**



**CORRECT**  
(Original container used)

**INCORRECT**  
(Placed loose in box)

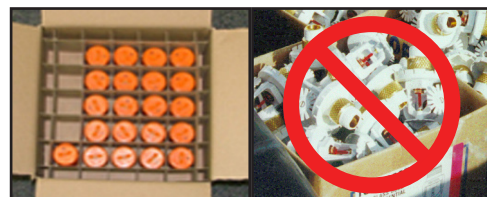

**CORRECT**  
(Protected with caps)

**INCORRECT**  
(Protective caps not used)



**CORRECT**  
(Piping is in place at the ceiling)

**INCORRECT**  
(Sprinkler at floor level)



**CORRECT**  
(Special installation wrenches)

**INCORRECT**  
(Designated wrench not used)

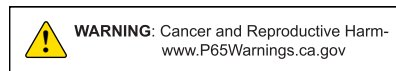

**! WARNING**

Any sprinkler with a loss of liquid from the glass bulb or damage to the fusible element should be destroyed. Never install sprinklers that have been dropped, damaged, or exposed to temperatures exceeding the maximum ambient temperature allowed. Sprinklers that have been painted in the field must be replaced per NFPA 13. Protect sprinklers from paint and paint overspray in accordance with the installation standards. Do not clean sprinklers with soap and water, ammonia, or any other cleaning fluid. Do not use adhesives or solvents on sprinklers or their operating elements.

**Refer to the appropriate technical data page and NFPA standards for complete care, handling, installation, and maintenance instructions. For additional product and system information Viking data pages and installation instructions are available on the Viking Web site at [www.vikinggroupinc.com](http://www.vikinggroupinc.com).**



## BULLETIN

CARE AND HANDLING  
OF SPRINKLERS

The Viking Corporation, 210 N Industrial Park Drive, Hastings MI 49058  
 Telephone: 269-945-9501 Technical Services: 877-384-5464 Fax: 269-818-1680 Email: techsvcs@vikingcorp.com

## PROTECTIVE SPRINKLER SHIELDS AND CAPS

### General Handling and Storage:

Many Viking sprinklers are available with a plastic protective cap or shield temporarily covering the operating elements. The snap-on shields and caps are factory installed and are intended to help protect the operating elements from mechanical damage during shipping, storage, and installation. NOTE: It is still necessary to follow the care and handling instructions on the appropriate sprinkler technical data sheets\* when installing sprinklers with bulb shields or caps.

### WHEN TO REMOVE THE SHIELDS AND CAPS:

NOTE: SHIELDS AND CAPS MUST BE REMOVED FROM SPRINKLERS BEFORE PLACING THE SYSTEM IN SERVICE!

Remove the shield or cap from the sprinkler only after checking all of the following:

- The sprinkler has been installed\*.
- The wall or ceiling finish work is completed where the sprinkler is installed and there no longer is a potential for mechanical damage to the sprinkler operating elements.

**SHIELDS AND CAPS MUST BE REMOVED FROM SPRINKLERS BEFORE PLACING THE SYSTEM IN SERVICE!**

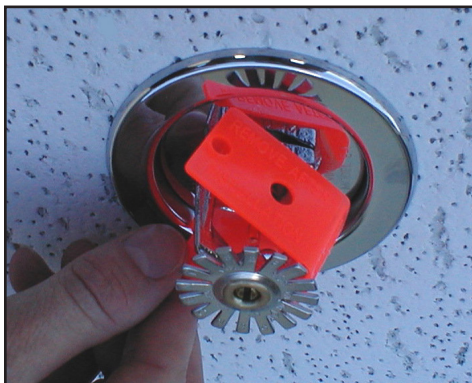

Figure 1: Sprinkler shield being removed from a pendent sprinkler.



Figure 2: Sprinkler cap being removed from a pendent sprinkler.



Figure 3: Sprinkler cap being removed from an upright sprinkler.

## HOW TO REMOVE SHIELDS AND CAPS:

No tools are necessary to remove the shields or caps from sprinklers. DO NOT use any sharp objects to remove them! **Take care not to cause mechanical damage to sprinklers when removing the shields or caps.** When removing caps from fusible element sprinklers, use care to prevent dislodging ejector springs or damaging fusible elements. NOTE: Squeezing the sprinkler cap excessively could damage sprinkler fusible elements.

- To remove the shield, simply pull the ends of the shield apart where it is snapped together. Refer to Figure 1.
- To remove the cap, turn it slightly and pull it off the sprinkler. Refer to Figures 2 and 3.

### NOTICE

Refer to the current sprinkler technical data page to determine the correct sprinkler wrench for the model of sprinkler used.

### WARNING

Never install sprinklers that have been dropped, damaged, or exposed to temperatures in excess of the maximum ambient temperature allowed.

\* Refer to the appropriate current technical data pages for complete care, handling, and installation instructions. Data pages are included with each shipment from Viking or Viking distributors. They can also be found on the Web site at [www.vikinggroupinc.com](http://www.vikinggroupinc.com).



## BULLETIN

CARE AND HANDLING  
OF SPRINKLERS

The Viking Corporation, 210 N Industrial Park Drive, Hastings MI 49058  
 Telephone: 269-945-9501 Technical Services: 877-384-5464 Fax: 269-818-1680 Email: techsvcs@vikingcorp.com



**CONCEALED COVER ASSEMBLIES ARE FRAGILE!**  
**TO ASSURE SATISFACTORY PERFORMANCE OF THE PRODUCT, HANDLE WITH CARE.**

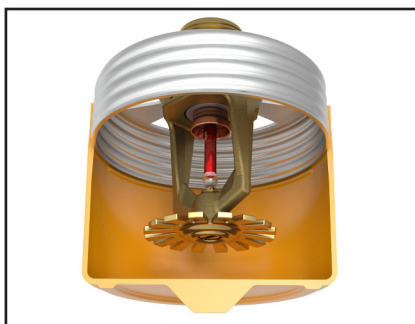

Concealed Sprinkler and Adapter  
 Assembly with Protective Cap

Concealed Sprinkler and Adapter  
 Assembly (Protective Cap Removed)



Cover Plate Assembly  
 (Pendent Cover 12381 shown)



#### GENERAL HANDLING AND STORAGE INSTRUCTIONS:

- Do not store in temperatures exceeding 100 °F (38 °C). Avoid direct sunlight and confined areas subject to heat.
- Protect sprinklers and cover assemblies during storage, transport, handling, and after installation.
  - Use original shipping containers.
  - Do not place sprinklers or cover assemblies loose in boxes, bins, or buckets.
- Keep the sprinkler bodies covered with the protective sprinkler cap any time the sprinklers are shipped or handled, during testing of the system, and while ceiling finish work is being completed.
- Use only the designated Viking recessed sprinkler wrench (refer to the appropriate sprinkler data page) to install these sprinklers. **NOTE:** The protective cap is temporarily removed during installation and then placed back on the sprinkler for protection until finish work is completed.
- Do not over-tighten the sprinklers into fittings during installation.
- Do not use the sprinkler deflector to start or thread the sprinklers into fittings during installation.
- Do not attempt to remove drywall, paint, etc., from the sprinklers.
- Remove the plastic protective cap from the sprinkler before attaching the cover plate assembly. **PROTECTIVE CAPS MUST BE REMOVED FROM SPRINKLERS BEFORE PLACING THE SYSTEM IN SERVICE!**

Refer to the appropriate current technical data pages for complete care, handling, and installation instructions. Data pages are included with each shipment from Viking or Viking distributors. They can also be found on the Web site at [www.vikinggroupinc.com](http://www.vikinggroupinc.com).



## BULLETIN

CARE AND HANDLING  
OF SPRINKLERS

The Viking Corporation, 210 N Industrial Park Drive, Hastings MI 49058

Telephone: 269-945-9501 Technical Services: 877-384-5464 Fax: 269-818-1680 Email: techsvcs@vikingcorp.com

## USE THE FOLLOWING PRECAUTIONS WHEN HANDLING WAX-COATED SPRINKLERS

Many of Viking's sprinklers are available with factory-applied wax coating for corrosion resistance. These sprinklers MUST receive appropriate care and handling to avoid damaging the wax coating and to assure satisfactory performance of the product.

### General Handling and Storage of Wax-Coated Sprinklers:

- Store the sprinklers in a cool, dry place (in temperatures below the maximum ambient temperature allowed for the sprinkler temperature rating. Refer to Table 1 below.)
- Store containers of wax-coated sprinklers separate from other sprinklers.
- Protect the sprinklers during storage, transport, handling, and after installation.
- Use original shipping containers.
- Do not place sprinklers in loose boxes, bins, or buckets.

### Installation of Wax-Coated Sprinklers:

Use only the special sprinkler head wrench designed for installing wax-coated Viking sprinklers (any other wrench may damage the unit).

- Take care not to crack the wax coating on the units.
- For touching up the wax coating after installation, wax is available from Viking in bar form. Refer to Table 1 below. The coating MUST be repaired after sprinkler installation to protect the corrosion-resistant properties of the sprinkler.
- Use care when locating sprinklers near fixtures that can generate heat. Do not install sprinklers where they would be exposed to temperatures exceeding the maximum recommended ambient temperature for the temperature rating used.
- Inspect the coated sprinklers frequently soon after installation to verify the integrity of the corrosion resistant coating. Thereafter, inspect representative samples of the coated sprinklers in accordance with NFPA 25. Close up visual inspections are necessary to determine whether the sprinklers are being affected by corrosive conditions.

TABLE 1

Sprinkler Temperature Rating (Fusing Point)	Wax Part Number	Wax Melting Point	Maximum Ambient Ceiling Temperature <sup>1</sup>	Wax Color
155 °F (68 °C) / 165 °F (74 °C)	02568A	148 °F (64 °C)	100 °F (38 °C)	Light Brown
175 °F (79 °C)	04146A	161 °F (71 °C)	150 °F (65 °C)	Brown
200 °F (93 °C)	04146A	161 °F (71 °C)	150 °F (65 °C)	Brown
220 °F (104 °C)	02569A	170 °F (76 °C)	150 °F (65 °C)	Dark Brown
286 °F (141 °C)	02569A	170 °F (76 °C)	150 °F (65 °C)	Dark Brown

<sup>1</sup> Based on NFPA-13. Other limits may apply, depending on fire loading, sprinkler location, and other requirements of the Authority Having Jurisdiction. Refer to specific installation standards.



Never install sprinklers that have been dropped, damaged, or exposed to temperatures in excess of the maximum ambient temperature allowed.

Refer to the appropriate current technical data pages for complete care, handling, and installation instructions. Data pages are included with each shipment from Viking or Viking distributors. They can also be found on the Web site at [www.vikinggroupinc.com](http://www.vikinggroupinc.com).



## TECHNICAL DATA

## SPRINKLER OVERVIEW

The Viking Corporation, 210 N Industrial Park Drive, Hastings MI 49058

Telephone: 269-945-9501 Technical Services: 877-384-5464 Fax: 269-818-1680 Email: techsvcs@vikingcorp.com

### 1. DESCRIPTION

Viking fire sprinklers consist of a threaded frame with a specific waterway or orifice size and a deflector for distributing water in a specified pattern. A closed or sealed sprinkler refers to a complete assembly, including the thermosensitive operating element. An open sprinkler does not use an operating element and is open at all times. The distribution of water is intended to extinguish a fire or to control its spread.

Viking sprinklers are available in several models and styles. Refer to specific sprinkler technical data pages for available styles, finishes, temperature ratings, thread sizes, and nominal K-Factors for the particular model selected.

### 2. LISTINGS AND APPROVALS

Refer to the Approval Charts on the appropriate sprinkler technical data page(s) and/or approval agency listings.



**WARNING:** Cancer and Reproductive Harm-  
www.P65Warnings.ca.gov

### 3. TECHNICAL DATA

#### Pressure Ratings:

Maximum allowable water working pressure is 175 psig (12 Bar) unless rated and specified for high water working pressure [250 psig (17.2 bar)].

#### Sprinkler Identification:

Viking sprinklers are identified and marked with the word "Viking", the sprinkler identification number (SIN) consisting of "VK" plus a three digit number\*, the model letter, and the year of manufacture.

#### Available Finishes:

Viking sprinklers are available in several decorative finishes. Some models are available with corrosion-resistant coatings or are fabricated from non-corrosive material. Refer to the sprinkler technical data page for additional information.

#### Available Temperature Ratings:

Viking sprinklers are available in several temperature ratings that relate to a specific temperature classification. Applicable installation rules mandate the use and limitations of each temperature classification. In selecting the appropriate temperature classification, the maximum expected ceiling temperature must be known. When there is doubt as to the maximum temperature at the sprinkler location, a maximum-reading thermometer should be used to determine the temperature under conditions that would show the highest readings to be expected. In addition, recognized installation rules may require a higher temperature classification, depending upon sprinkler location, occupancy classification, commodity classification, storage height, and other hazards. In all cases, the maximum expected ceiling temperature dictates the lowest allowable temperature classification. Sprinklers located immediately adjacent to a heat source may require a higher temperature rating.

#### K-Factors:

Viking sprinklers are available in several orifice sizes with related K-Factors. The orifice is a tapered waterway and, therefore, the K-Factor given is nominal. Nominal U.S. K-Factors are provided in accordance with the 1999 edition of NFPA 13, Section 3-2.3. Refer to the specific data page for appropriate K-Factor information.

#### Available Styles:

Viking sprinklers are available for installation in several positions as indicated by a stamping on the deflector. The deflector style dictates the appropriate installation position of the sprinkler; it breaks the solid stream of water issuing from the sprinkler orifice to form a specific spray pattern. The following list indicates the various styles and identification of Viking sprinklers.

**UPRIGHT SPRINKLER:** A sprinkler intended to be installed with the deflector above the frame so water flows upward through the orifice, striking the deflector and forming an umbrella-shaped spray pattern downward. Marked "SSU" (Standard Sprinkler Upright) or "UPRIGHT" on the deflector.

**PENDENT SPRINKLER:** A sprinkler intended to be oriented with the deflector below the frame so water flows downward through the orifice, striking the deflector and forming an umbrella-shaped spray pattern downward. Marked "SSP" (Standard Sprinkler Pendent) or "PENDENT" on the deflector.

**CONVENTIONAL SPRINKLER:** An "old style" sprinkler intended to be installed with the deflector in either the upright or pendent position. The deflector provides a spherical type pattern with 40 to 60 percent of the water initially directed downward and a proportion directed upward. Must be installed in accordance with installation rules for conventional or old style sprinklers. **DO NOT USE AS A REPLACEMENT FOR STANDARD SPRAY SPRINKLERS.** Marked "C U/P" (Conventional Upright/Pendent) on the deflector.

Viking Technical Data may be found on  
The Viking Corporation's Web site at  
<http://www.vikinggroupinc.com>.  
The Web site may include a more recent  
edition of this Technical Data Page.



## TECHNICAL DATA

## SPRINKLER OVERVIEW

The Viking Corporation, 210 N Industrial Park Drive, Hastings MI 49058

Telephone: 269-945-9501 Technical Services: 877-384-5464 Fax: 269-818-1680 Email: techsvcs@vikingcorp.com

**VERTICAL SIDEWALL (VSW) SPRINKLER:** A sprinkler intended for installation near the wall and ceiling. The deflector provides a water spray pattern outward in a quarter-spherical pattern and can be installed in the upright or pendent position with the flow arrow in the direction of discharge. Marked "SIDEWALL" on the deflector with an arrow and the word "FLOW". (Note: Some vertical sidewall sprinklers can only be installed in the upright or pendent position—in this case, the sprinkler will also be marked "UPRIGHT" or "PENDENT".)

**HORIZONTAL SIDEWALL (HSW) SPRINKLER:** A sprinkler intended for installation near the wall and ceiling. The special deflector provides a water spray pattern outward in a quarter-spherical pattern. Most of the water is directed away from the nearby wall with a small portion directed at the wall behind the sprinkler. The top of the deflector is oriented parallel with the ceiling or roof. The flow arrows point in the direction of discharge. Marked "SIDEWALL" and "TOP" with an arrow and the word "FLOW".

**EXTENDED COVERAGE (EC) SPRINKLER:** A spray sprinkler designed to discharge water over an area having the maximum dimensions indicated in the individual listings. Maximum area of coverage, minimum flow rate, orifice size, and nominal K-Factor are specified in the individual listings. EC sprinklers are intended for Light-Hazard occupancies with smooth, flat, horizontal ceilings unless otherwise specified. In addition to the above markings, the sprinkler is marked "EC".

**QUICK RESPONSE (QR) SPRINKLER:** A spray sprinkler with a fast-actuating operating element. The use of quick response sprinklers may be limited due to occupancy and hazard. Refer to the Authority Having Jurisdiction (AHJ) prior to installing.

**QUICK RESPONSE EXTENDED COVERAGE (QREC) SPRINKLER:** A spray sprinkler designed to discharge water over an area having the maximum dimensions indicated in the individual listing. This is a sprinkler with an operating element that meets the criteria for quick response. QREC sprinklers are only intended for Light Hazard occupancies. The sprinkler is marked "QREC".

**FLUSH SPRINKLER:** A decorative spray sprinkler intended for installation with a concealed piping system. The unit is mounted flush with the ceiling or wall, with the fusible link exposed. Upon actuation, the deflector extends beyond the ceiling or wall to distribute water discharge. The sprinkler is marked "SSP", "PEND", or "SIDEWALL" and "TOP".

**CONCEALED SPRINKLER:** A decorative spray sprinkler intended for installation with a concealed piping system. The sprinkler is hidden from view by a cover plate installed flush with the ceiling or wall. During fire conditions, the cover plate detaches, and upon sprinkler actuation, the deflector extends beyond the ceiling or wall to distribute water discharge. The sprinkler is marked "SSP", "PEND", or "SIDEWALL" and "TOP".

**RECESSED SPRINKLER:** A spray sprinkler assembly intended for installation with a concealed piping system. The assembly consists of a sprinkler installed in a decorative adjustable recessed escutcheon that minimizes the protrusion of the sprinkler beyond the ceiling or wall without adversely affecting the sprinkler distribution or sensitivity. Refer to the appropriate technical data page for allowable sprinkler models, temperature ratings, and occupancy classifications. DO NOT RECESS ANY SPRINKLER NOT LISTED FOR USE WITH THE ESCUTCHEON.

**CORROSION-RESISTANT SPRINKLER:** A special service sprinkler with non-corrosive protective coatings, or that is fabricated from non-corrosive material, for use in atmospheres that would normally corrode sprinklers.

**DRY SPRINKLER:** A special-service sprinkler intended for installation on dry pipe systems or wet pipe systems where the sprinkler is subject to freezing temperatures. The unit consists of a sprinkler permanently secured to an extension nipple with a sealed inlet end to prevent water from entering the nipple until the sprinkler operates. The unit MUST be installed in a tee fitting. Dry upright sprinklers are marked with the "B" dimension [distance from the face of the fitting (tee) to the top of the deflector]. Dry pendent and sidewall sprinklers are marked with the "A" dimension [the distance from the face of fitting (tee) to the finished surface of the ceiling or wall].

**LARGE DROP SPRINKLER:** A type of special application sprinkler used to provide fire control of specific high-challenge fire hazards. Large drop sprinklers are designed to produce an umbrella-shaped spray pattern downward with a higher percentage of "large" water droplets than standard spray sprinklers. The sprinkler has an extra-large orifice with a nominal K-Factor of 11.2. Marked "HIGH CHALLENGE" and "UPRIGHT".

**EARLY SUPPRESSION FAST-RESPONSE (ESFR) SPRINKLER:** A sprinkler intended to provide fire suppression of specific high-challenge fire hazards through the use of a fast response fusible link, 14.0, 16.8, or 25.2 nominal K-Factor, and special deflector. ESFR sprinklers are designed to produce high-momentum water droplets in a hemispherical pattern below the deflector. This permits penetration of the fire plume and direct wetting of the burning fuel surface while cooling the atmosphere early in the development of a high-challenge fire. Marked "ESFR" and "UPRIGHT" or "PEND".

**INTERMEDIATE LEVEL/RACK STORAGE SPRINKLER:** A standard spray sprinkler assembly designed to protect its operating element from the spray of sprinklers installed at higher elevations. The assembly consists of a standard or large orifice upright or pendent sprinkler with an integral upright or pendent water shield and guard assembly. Use only those sprinklers that have been tested and listed for use with the assembly. Refer to the technical data page for allowable sprinkler models.

**RESIDENTIAL SPRINKLER:** A sprinkler intended for use in the following occupancies: one- and two-family dwellings with the fire protection sprinkler system installed in accordance with NFPA 13D; residential occupancies up to four stories in height with the fire protection system installed in accordance with NFPA 13R; and where allowed by the Authority Having Jurisdiction in residential portions of any occupancy with the fire protection system installed in accordance with NFPA 13.





## TECHNICAL DATA

## SPRINKLER OVERVIEW

The Viking Corporation, 210 N Industrial Park Drive, Hastings MI 49058

Telephone: 269-945-9501 Technical Services: 877-384-5464 Fax: 269-818-1680 Email: techsvcs@vikingcorp.com

Residential sprinklers have a unique distribution pattern and utilize a “fast response” heat sensitive operating element. They enhance survivability in the room of fire origin and are designed to provide a life safety environment for a minimum of ten minutes. For this reason, residential sprinklers must not be used to replace standard sprinklers unless tested for and approved by the Authority Having Jurisdiction. In addition to standard markings, the unit is identified as “RESIDENTIAL SPRINKLER” or “RES”.

#### 4. INSTALLATION

Refer to appropriate NFPA Installation Standards.

#### 5. OPERATION

Refer to the appropriate sprinkler technical data page(s).

#### 6. INSPECTIONS, TESTS AND MAINTENANCE

Refer to NFPA 25 for Inspection, Testing and Maintenance requirements.

#### 7. AVAILABILITY

Viking sprinklers are available through a network of domestic and international distributors. See The Viking Corporation web site for the closest distributor or contact The Viking Corporation.

#### 8. GUARANTEE

For details of warranty, refer to Viking’s current list price schedule or contact Viking directly.

**IMPORTANT: Always refer to Bulletin Form No. F\_091699 - Care and Handling of Sprinklers and the appropriate sprinkler general care, installation, and maintenance guide. Vikings sprinklers are to be installed in accordance with the latest edition of Viking technical data, the appropriate standards of NFPA, FM Global, LPCB, APSAD, VdS or other similar organizations, and also with the provisions of governmental codes, ordinances, and standards, whenever applicable. The sprinkler technical data page may contain installation requirements specific for the sprinkler model selected. The use of certain types of sprinklers may be limited due to occupancy and hazard. Refer to the Authority Having Jurisdiction prior to installation.**



## BULLETIN

## BEST PRACTICES FOR RESIDENTIAL SPRINKLER HANDLING & INSTALLATION

The Viking Corporation, 210 N Industrial Park Drive, Hastings MI 49058  
 Telephone: 269-945-9501 Technical Services: 877-384-5464 Fax: 269-818-1680 Email: techsvcs@vikingcorp.com  
 Visit the Viking website for the latest edition of this technical data page.

### SPRINKLERS ARE FRAGILE - HANDLE WITH CARE!

- Always keep sprinklers in a cool dry place.
- Protect sprinklers during storage, transport and handling as well as before, during and after installation. Refer to Viking's Care and Handling of Sprinklers Bulletin [Form No. F\\_091699<sup>2</sup>](#).
- Proper transit, storage and installation of sprinklers in a high-heat environment is a must. Care should be taken to prevent sprinklers from being exposed to ambient heat conditions in excess of those referenced in installation standards.
- Do not stage or store sprinklers on the job site in advance in a non-conditioned space prior to installation.
- Keep sprinklers in the original packaging and check temperature indicators on box label prior to installation. If the indicator has turned black, DO NOT install any product contained in the box. Refer to Viking product return policies.
- Temperatures exceeding the maximum ambient temperature of the sprinkler temperature-rating during storage, transport, handling and installation must be avoided.
- Per NFPA standards 13, 13R, and 13D, sprinklers installed where maximum ambient temperatures are at or over 101 °F (38 °C ) through 150 °F (66 °C) shall be intermediate temperature-rated sprinklers. Additionally, if sprinklers are installed in an unventilated concealed space under an uninsulated roof or in an unventilated attic, they shall be of intermediate temperature classification.
- Sprinklers installed where ambient temperatures are at or below 100 °F (38 °C) may be either ordinary or intermediate temperature-rated sprinklers. Refer to NFPA standards 13R 6.2.3.1 and 13D 7.5.6.1.
- Rough-in of sprinkler piping during hot weather conditions should not include the installation of sprinklers unless reasonable ambient temperatures can be maintained. Ambient temperatures that are considered when choosing the temperature rating for a sprinkler should take into account the range of ambient temperatures that are expected from installation through establishment and maintenance of temperature in a conditioned space. Appropriate insulation may be considered. **Example:** An ordinary temperature sprinkler should not be exposed to maximum ambient temperature higher than 100 °F (38 °C) or more. Refer to NFPA 13, Table 6.2.5.1, NFPA 13R, 6.2.3.1 and NFPA 13D, 7.5.6.1.
- CPVC fire sprinkler products exposed to high ambient temperatures (e.g. installed in unventilated, concealed spaces such as attics) should be insulated to maintain a cooler environment. Refer to Viking Plastics Installation and Design Manual, [Form No. F\\_080712<sup>2</sup>](#), for care and handling procedures.
- Protect all sprinklers and connecting CPVC piping in attic spaces and unvented concealed spaces from excessive heat exposure above 100 °F (38 °C). To separate excessive attic heat, properly tent and fully insulate all pipe in unconditioned spaces.
- Pressure relief valves should be installed on wet sprinkler systems where there is a risk of over-pressurization of a checked water supply, due to thermal expansion. Refer to NFPA 13, 7.1.2.1 and NFPA 13D, A.5.2.2.2.
- Fire sprinkler systems should be installed per current referenced editions of building codes and installation standards adopted in the jurisdiction where work is being performed.

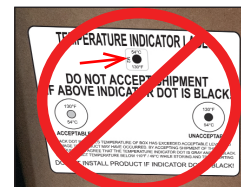

**INCORRECT**  
(Heat exposure)

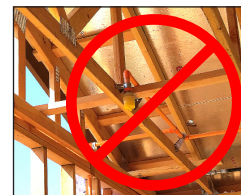

**INCORRECT**  
(Unconditioned at rough-in)



**INCORRECT**  
(Exposed piping)



**INCORRECT**  
(No pressure relief valve)

**WARNING:** Cancer and Reproductive Harm-  
[www.P65Warnings.ca.gov](http://www.P65Warnings.ca.gov)

<sup>1</sup>Hot weather condition is defined as temperatures that can reach the maximum ambient temperature-rating of the sprinkler.

<sup>2</sup>Clicking on blue hyperlink will open referenced document.

### ⚠ WARNING

Any sprinkler with a loss of liquid from the glass bulb or damage to the fusible element should be destroyed. Never install sprinklers that have been dropped, damaged, or exposed to temperatures exceeding the maximum ambient temperature allowed. Sprinklers that have been painted in the field must be replaced per NFPA 13. Protect sprinklers from paint and paint overspray in accordance with the installation standards. Do not clean sprinklers with soap and water, ammonia, or any other cleaning fluid. Do not use adhesives or solvents on sprinklers or their operating elements.

**Refer to the appropriate technical data page and NFPA standards for complete care, handling, installation, and maintenance instructions. For additional product and system information Viking data pages and installation instructions are available on the Viking Web site at [www.vikinggroupinc.com](http://www.vikinggroupinc.com).**

**BULLETIN****REGULATORY AND HEALTH  
WARNINGS**

The Viking Corporation, 210 N Industrial Park Drive, Hastings MI 49058

Telephone: 269-945-9501 Technical Services: 877-384-5464 Fax: 269-818-1680 Email: [techsvcs@vikingcorp.com](mailto:techsvcs@vikingcorp.com)

Visit the Viking website for the latest edition of this technical data page [www.vikinggroupinc.com](http://www.vikinggroupinc.com)

**1. DESCRIPTION**

Regulatory and Health Warnings applying to materials used in the manufacture and construction of fire protection products are provided herein as they relate to legally mandated jurisdictional regions.

**⚠ WARNING****STATE OF CALIFORNIA, USA**

Installing or servicing fire protection products such as sprinklers, valves, piping etc. can expose you to chemicals including, but not limited to, lead, nickel, butadiene, titanium dioxide, chromium, carbon black, and acrylonitrile which are known to the State of California to cause cancer or birth defects or other reproductive harm.

For more information, go to [www.P65Warnings.ca.gov](http://www.P65Warnings.ca.gov)

**2. WARRANTY TERMS AND CONDITIONS**

For details of warranty, refer to Viking's current list price schedule at [www.vikinggroupinc.com](http://www.vikinggroupinc.com) or contact Viking directly.



## TECHNICAL DATA

## FREEDOM® RESIDENTIAL HORIZONTAL SIDEWALL SPRINKLER VK486 (K4.0)

The Viking Corporation, 210 N Industrial Park Drive, Hastings MI 49058

Telephone: 269-945-9501 Technical Services: 877-384-5464 Fax: 269-818-1680 Email: techsvcs@vikingcorp.com

Visit the Viking website for the latest edition of this technical data page: [www.vikinggroupinc.com](http://www.vikinggroupinc.com)

### 1. DESCRIPTION

Viking Freedom® Residential Horizontal Sidewall Sprinkler VK486 is a small, thermostatic, glass-bulb residential sprinkler available in several different finishes and temperature ratings to meet varying design requirements. The Electroless Nickel PTFE (ENT) coating has been investigated for installation in corrosive atmospheres and is C-UL-US-EU Listed as corrosion resistant as indicated in the Approval Chart. The sprinkler orifice design, with a K-Factor of 4.0 (57.7 metric†), allows efficient use of available water supplies for the hydraulically designed fire-protection system. The glass bulb operating element and special deflector characteristics meet the challenges of residential sprinkler standards.

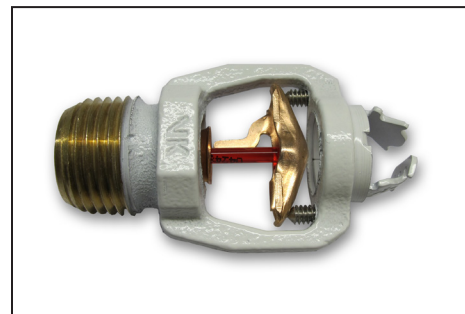

### 2. LISTINGS AND APPROVALS

 **UL Listed (C-UL-US-EU):** Category VKKW

 **VdS Approved**

 **WARNING:** Cancer and Reproductive Harm-  
[www.P65Warnings.ca.gov](http://www.P65Warnings.ca.gov)

Refer to the Approval Chart and Design Criteria for C-UL-US-EU Listing requirements that must be followed.

### 3. TECHNICAL DATA

#### Specifications:

Available since 2011.

Minimum Operating Pressure: Refer to the Approval Chart.

Maximum Working Pressure: 175 psi (12 bar). Factory tested hydrostatically to 500 psi (34.5 bar).

Thread size: 1/2" (15 mm) NPT

Nominal K-Factor: 4.0 U.S. (57.7 metric†)

† Metric K-factor measurement shown is in Bar. When pressure is measured in kPa, divide the metric K-factor shown by 10.0.

Glass-bulb fluid temperature rated to -65 °F (-55 °C)

Overall Length: 2-7/16" (62 mm)

Covered by the following US Patent numbers: 7,854,269 and 7,712,218

#### Material Standards:

Frame Casting: QM Brass and Brass UNS-C84400

Deflector: Phosphor Bronze UNS-C51000

Bulb: Glass, nominal 3 mm diameter

Belleville Spring Sealing Assembly: Nickel Alloy, coated on both sides with PTFE Tape

Pip Cap and Insert Assembly: Copper UNS-C11000 and Stainless Steel UNS-S30400

Compression Screws: 18-8 Stainless Steel

Yoke: Phosphor Bronze UNS-C51000

**Ordering Information:** (Also refer to the current Viking price list.)

**Sprinkler:** Base Part No. 17315

Order Sprinkler VK486 by first adding the appropriate suffix for the sprinkler finish and then the appropriate suffix for the temperature rating to the sprinkler base part number.

Finish Suffix: Brass = A, Chrome = F, White Polyester = M-/W, Black Polyester = M-/B

Temperature Suffix: 155 °F (68 °C) = B, 175 °F (79 °C) = D

For example, sprinkler VK486 with a Brass finish and a 155 °F (68 °C) temperature rating = Part No. 17315AB.

#### Available Finishes And Temperature Ratings:

Refer to Table 1.

**Accessories:** (Also refer to the Viking website.)

#### Sprinkler Wrenches:

A. Standard Wrench: Part No. 21475M/B (available since 2017)

B. Wrench for recessed sprinklers: Part No. 13655W/B\* (available since 2006)

\*A 1/2" ratchet is required (not available from Viking).



**TECHNICAL DATA**

**FREEDOM® RESIDENTIAL HORIZONTAL SIDEWALL SPRINKLER VK486 (K4.0)**

The Viking Corporation, 210 N Industrial Park Drive, Hastings MI 49058  
 Telephone: 269-945-9501 Technical Services: 877-384-5464 Fax: 269-818-1680 Email: techsvcs@vikingcorp.com  
 Visit the Viking website for the latest edition of this technical data page: www.vikinggroupinc.com

**Sprinkler Cabinets:**

- A. Six-head capacity: Part No. 01724A (available since 1971)
- B. Twelve-head capacity: Part No. 01725A (available since 1971)

**4. INSTALLATION**

Refer to appropriate NFPA Installation Standards.

**5. OPERATION**

During fire conditions, the heat-sensitive liquid in the glass bulb expands, causing the glass to shatter, releasing the yoke, pip cap, and sealing spring assembly. Water flowing through the sprinkler orifice strikes the sprinkler deflector, forming a uniform spray pattern to extinguish or control the fire.

**6. INSPECTIONS, TESTS AND MAINTENANCE**

Refer to NFPA 25 for Inspection, Testing and Maintenance requirements.

**7. AVAILABILITY**

Viking Sprinkler VK486 is available through a network of domestic and international distributors. See The Viking Corporation web site for the closest distributor or contact The Viking Corporation.

**8. GUARANTEE**

For details of warranty, refer to Viking's current list price schedule or contact Viking directly.

**TABLE 1: AVAILABLE SPRINKLER TEMPERATURE RATINGS AND FINISHES**

Sprinkler Temperature Classification	Sprinkler Nominal Temperature Rating <sup>1</sup>	Maximum Ambient Ceiling Temperature <sup>2</sup>	Bulb Color
Ordinary	155 °F (68 °C)	100 °F (38 °C)	Red
Intermediate	175 °F (79 °C)	150 °F (65 °C)	Yellow

**Sprinkler Finishes:** Brass, Chrome, White Polyester, and Black Polyester.

**Footnotes**

<sup>1</sup> The sprinkler temperature rating is stamped on the deflector.

<sup>2</sup> Based on NFPA-13. Other limits may apply, depending on fire loading, sprinkler location, and other requirements of the Authority Having Jurisdiction. Refer to specific installation standards.

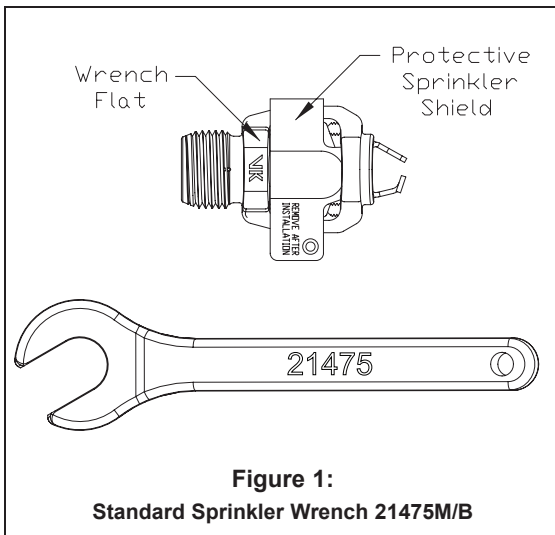

**Figure 1:**  
Standard Sprinkler Wrench 21475M/B

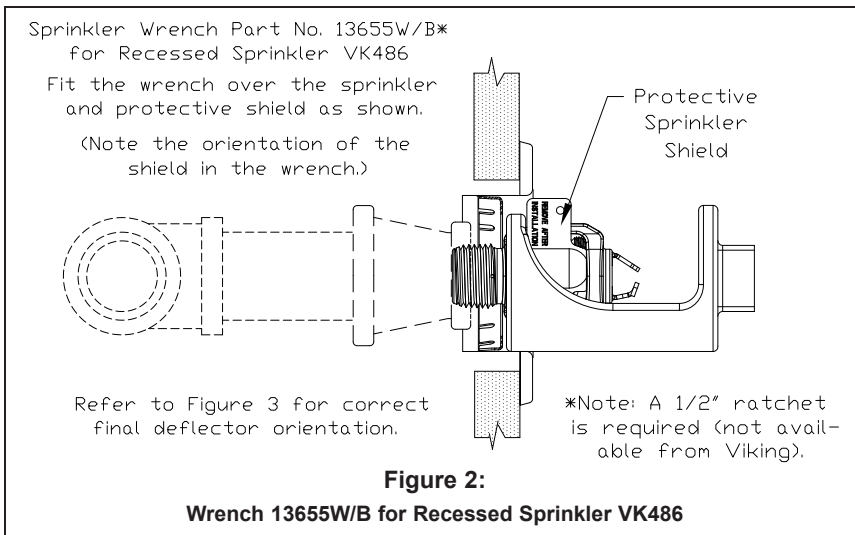

**Figure 2:**  
Wrench 13655W/B for Recessed Sprinkler VK486



## TECHNICAL DATA

## FREEDOM® RESIDENTIAL HORIZONTAL SIDEWALL SPRINKLER VK486 (K4.0)

The Viking Corporation, 210 N Industrial Park Drive, Hastings MI 49058  
 Telephone: 269-945-9501 Technical Services: 877-384-5464 Fax: 269-818-1680 Email: techsvcs@vikingcorp.com  
 Visit the Viking website for the latest edition of this technical data page: www.vikinggroupinc.com

### Approval Chart Viking VK486, 4.0 K-Factor Residential Horizontal Sidewall Sprinkler

For systems designed to NFPA 13D or NFPA 13R. For systems designed to NFPA 13, refer to the design criteria. For Ceiling types refer to current Editions of NFPA 13, 13R or 13D

Sprinkler Base Part Number <sup>1</sup>	SIN	NPT Thread Size		Nominal K-Factor		Maximum Water Working Pressure	Overall Length					
		Inches	mm	U.S.	metric <sup>2</sup>		Inches	mm				
17315	VK486	1/2	15	4.0	57.7	175 psi (12 bar)	2-7/16		62			
Max. Coverage Area <sup>3</sup> Width X Length Ft. X Ft. (m X m)	Max. Spacing Ft. (m)	Ordinary Temp Rating (155 °F/68 °C)		Intermediate Temp Rating (175 °F/79 °C)		Top of Deflector to Ceiling	Installation Type	Listings and Approvals <sup>4</sup>				Minimum Spacing Ft. (m)
		Flow <sup>3</sup> GPM (L/min)	Pressure <sup>3</sup> PSI (bar)	Flow <sup>3</sup> GPM (L/min)	Pressure <sup>3</sup> PSI (bar)			C-UL-US-EU <sup>5</sup>	VdS	NYC	NSF <sup>9</sup>	
12 X 12 (3.7 X 3.7)	12 (3.7)	11 (41.7)	7.6 (0.52)	11 (41.7)	7.6 (0.52)	4 to 6 inches	Standard surface-mounted escutcheons or recessed with the Micromatic® Model E-1, E-2, E-3, or G-1 Recessed Escutcheon	See Footnote 6 and 10.	See Footnote 6.	See Footnote 7.	See Footnote 6.	8 (2.4)
14 X 14 (4.3 X 4.3)	14 (4.3)	12 (45.5)	9 (0.62)	12 (45.5)	9 (0.62)							
16 X 16 (4.9 X 4.9)	16 (4.9)	13 (49.3)	10.6 (0.73)	13 (49.3)	10.6 (0.73)							
16 X 18 (4.9 X 5.5)	16 (4.9)	16 (60.6)	16 (1.10)	16 (60.6)	16 (1.10)							
16 X 20 (4.9 X 6.1)	16 (4.9)	22 (83.3)	30.3 (2.09)	22 (83.3)	30.3 (2.09)							
16 X 22 (4.9 X 6.7)	16 (4.9)	24 (90.8)	36 (2.48)	24 (90.8)	36 (2.48)							
18 X 18 (5.5 X 5.5)	18 (5.5)	18 (68.1)	20.3 (1.40)	19 (71.9)	22.6 (1.60)							
18 X 20 (5.5 X 6.1)	18 (5.5)	22 (83.3)	30.3 (2.09)	22 (83.3)	30.3 (2.09)							
20 X 20 (6.1 X 6.1)	20 (6.1)	22 (83.3)	30.3 (2.09)	22 (83.3)	30.3 (2.09)							
12 X 12 (3.7 X 3.7)	12 (3.7)	12 (45.5)	9 (0.62)	12 (45.5)	9 (0.62)							
14 X 14 (4.3 X 4.3)	14 (4.3)	12 (45.5)	9 (0.62)	13 (49.3)	10.6 (0.73)							
16 X 16 (4.9 X 4.9)	16 (4.9)	14 (53.0)	12.3 (0.84)	14 (53.0)	12.3 (0.84)							
16 X 18 (4.9 X 5.5)	16 (4.9)	16 (60.6)	16 (1.10)	16 (60.6)	16 (1.10)							
16 X 20 (4.9 X 6.1)	16 (4.9)	23 (87.1)	33.1 (2.28)	23 (87.1)	33.1 (2.28)							
16 X 22 (4.9 X 6.7)	16 (4.9)	26 (98.4)	42.3 (2.91)	26 (98.4)	42.3 (2.91)							
18 X 18 (5.5 X 5.5)	18 (5.5)	18 (68.1)	20.3 (1.40)	19 (71.9)	22.6 (1.60)							
18 X 20 (5.5 X 6.1)	18 (5.5)	23 (87.1)	33.1 (2.28)	23 (87.1)	33.1 (2.28)							
20 X 20 (6.1 X 6.1)	20 (6.1)	24 (90.8)	36 (2.48)	24 (90.8)	36 (2.48)							

#### Footnotes

- Part number shown is the base part number. For complete part number, refer to Viking's current price schedule.
- Metric K-factor measurement shown is when pressure is measured in Bar. When pressure is measured in kPa, divide the metric K-factor shown by 10.0.
- For areas of coverage smaller than shown, use the "Flow" and "Pressure" for the next larger area listed. Flows and pressures listed are per sprinkler. The distance from sprinklers to walls shall not exceed one-half the sprinkler spacing indicated for the minimum "Flow" and "Pressure" used.
- This chart shows the listings and approvals available at the time of printing. Other approvals may be in process. Check with the manufacturer for any additional approvals. Refer also to Design Criteria.
- Listed by Underwriter's Laboratories, Inc. for use in the U.S., Canada, and European Union.
- Approved Finishes are: Brass, Chrome, White Polyester, and Black Polyester <sup>8</sup>
- Meets New York City requirements, effective July 1, 2008.
- Other paint colors are available on request with the same C-UL-US-EU listings as the standard finish colors.
- UL Classified to : NSF/ANSI Standard 61, Drinking Water System Components (MH48034)
- Approved finish is Electroless Nickel PTFE (ENT). ENT is C-UL-US-EU Listed as corrosion resistant. ENT is available with standard surface-mounted escutcheons or the Micromatic Model E-1 Recessed Escutcheon.



**TECHNICAL DATA**

**FREEDOM® RESIDENTIAL HORIZONTAL SIDEWALL SPRINKLER VK486 (K4.0)**

The Viking Corporation, 210 N Industrial Park Drive, Hastings MI 49058  
 Telephone: 269-945-9501 Technical Services: 877-384-5464 Fax: 269-818-1680 Email: techsvcs@vikingcorp.com  
 Visit the Viking website for the latest edition of this technical data page: www.vikinggroupinc.com

**DESIGN CRITERIA**

(Also refer to the Approval Chart.)

**UL Listing Requirements (C-UL-US-EU):**

When using Viking Residential Horizontal Sidewall Sprinkler VK486 for systems designed to NFPA 13D or NFPA 13R, apply the listed areas of coverage and minimum water supply requirements shown in the Approval Chart.

For systems designed to NFPA 13: The number of design sprinklers is to be the four contiguous most hydraulically demanding sprinklers. The minimum required discharge from each of the four sprinklers is to be the greater of the following:

- The flow rates given in the Approval Chart for NFPA 13D and NFPA 13R applications for each listed area of coverage, **or**
- Calculated based on a minimum discharge of 0.1 gpm/sq. ft. over the “design area” in accordance with sections 8.5.2.1 or 8.6.2.1.2 of NFPA 13.
- Minimum distance between residential sprinklers: 8 ft. (2.4 m).
- The VK486 horizontal sidewall sprinkler deflector shall be located a minimum of 1-1/4” (31.8 mm) and a maximum of 6” (152 mm) from the wall on which it is installed.

**DEFLECTOR POSITION:** Install sprinkler VK486 with the leading edge of the deflector oriented parallel to the ceiling and the sprinkler frame arms oriented perpendicular to the ceiling (see Figure 4). **THE TOP SURFACE OF THE DEFLECTOR IS MARKED “TOP”.** The sprinkler must be oriented as shown in Figure 3 below.

**IMPORTANT: Always refer to Bulletin Form No. F\_091699 - Care and Handling of Sprinklers. Also refer to Form No. F\_080190, F\_080814, and F\_080415 for general care, installation, and maintenance information. Viking sprinklers are to be installed in accordance with the latest edition of Viking technical data, the appropriate standards of NFPA and any other similar Authorities Having Jurisdiction, and also with the provisions of governmental codes, ordinances, and standards, whenever applicable. Final approval and acceptance of all residential sprinkler installations must be obtained from the Authorities Having Jurisdiction.**

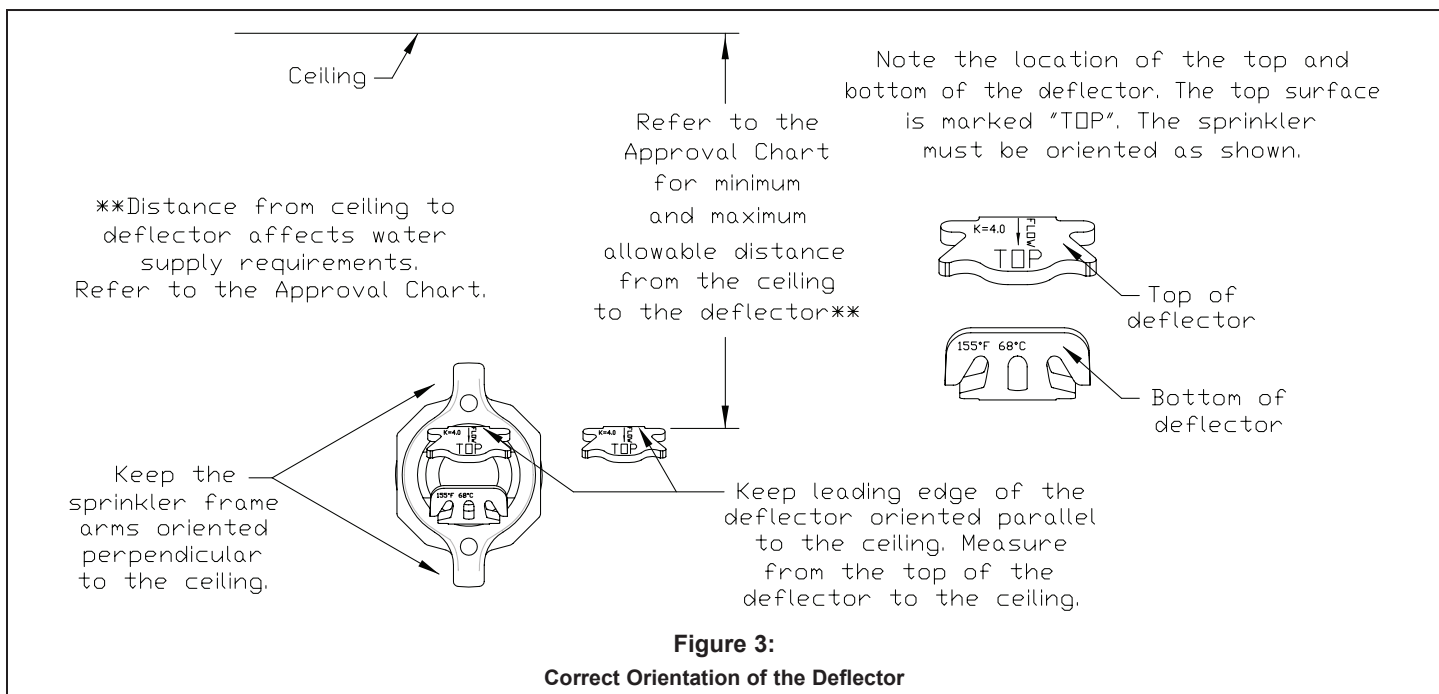



**TECHNICAL DATA**

**FREEDOM® RESIDENTIAL  
HORIZONTAL SIDEWALL  
SPRINKLER VK486 (K4.0)**

The Viking Corporation, 210 N Industrial Park Drive, Hastings MI 49058  
 Telephone: 269-945-9501 Technical Services: 877-384-5464 Fax: 269-818-1680 Email: techsvcs@vikingcorp.com  
 Visit the Viking website for the latest edition of this technical data page: www.vikinggroupinc.com

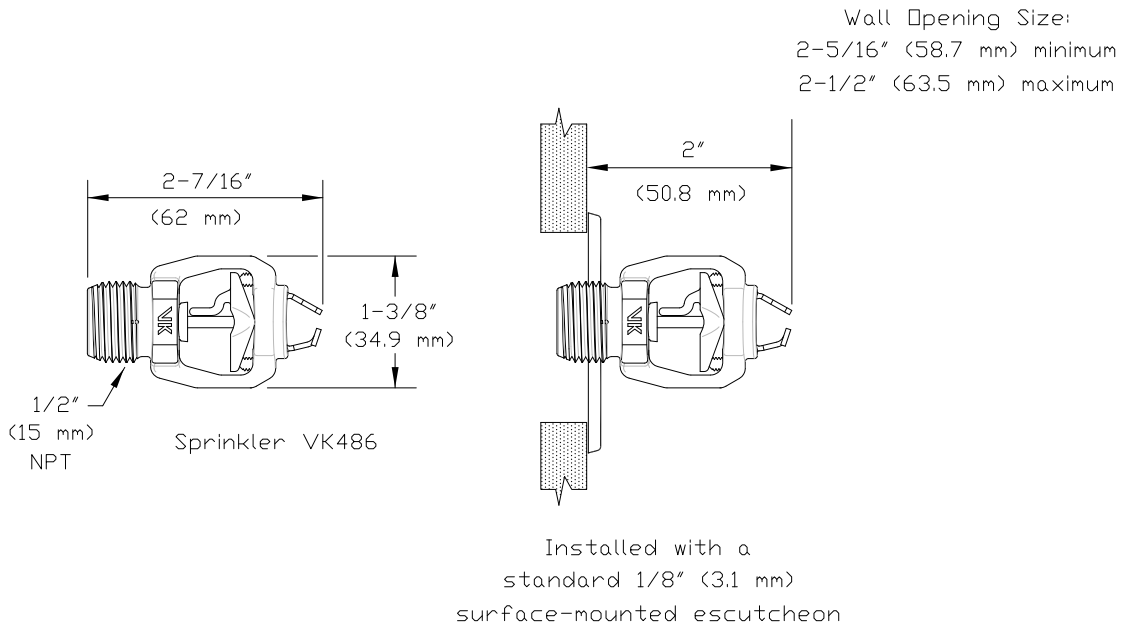

**Figure 4:**  
**Sprinkler VK486 Dimensions with a Standard Escutcheon and the Model F-1 Adjustable Escutcheon**

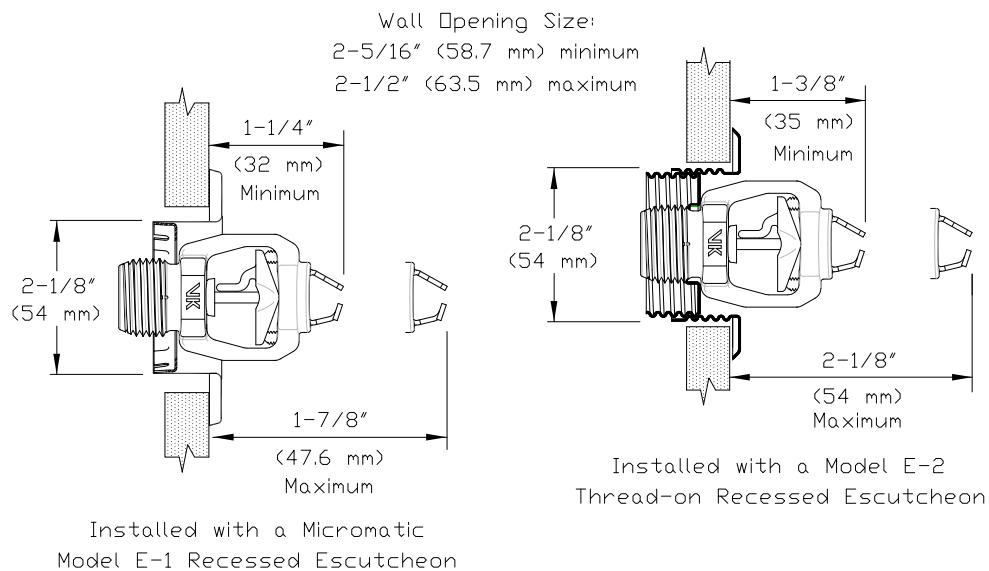

**Figure 5:**  
**Sprinkler VK486 Dimensions with the Model E-1 and E-2 Recessed Escutcheons**





TECHNICAL DATA

FREEDOM® RESIDENTIAL HORIZONTAL SIDEWALL SPRINKLER VK486 (K4.0)

The Viking Corporation, 210 N Industrial Park Drive, Hastings MI 49058  
Telephone: 269-945-9501 Technical Services: 877-384-5464 Fax: 269-818-1680 Email: techsvcs@vikingcorp.com  
Visit the Viking website for the latest edition of this technical data page: www.vikinggroupinc.com

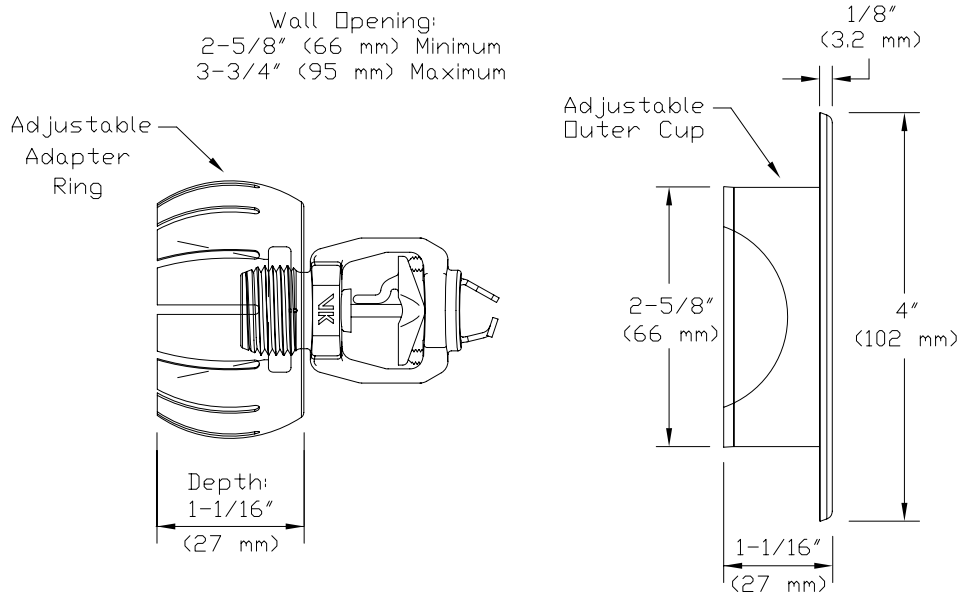
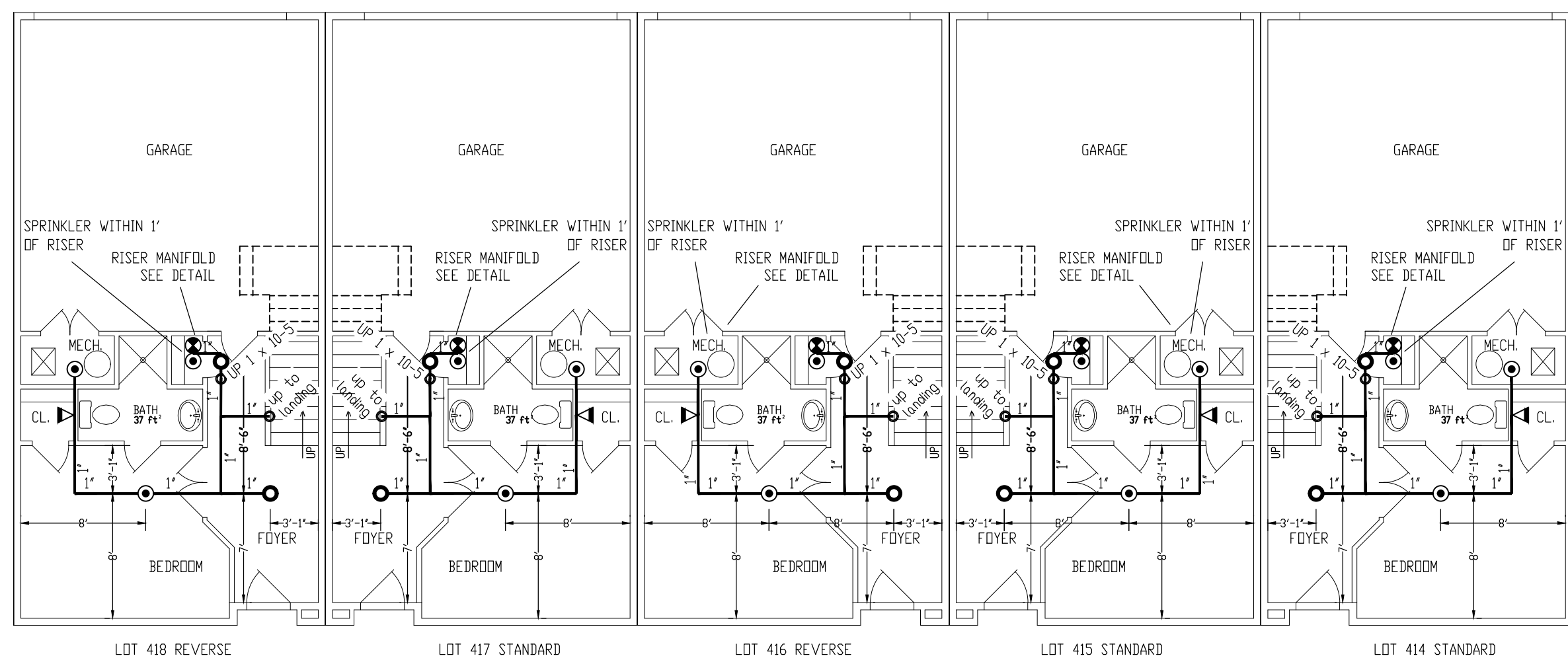
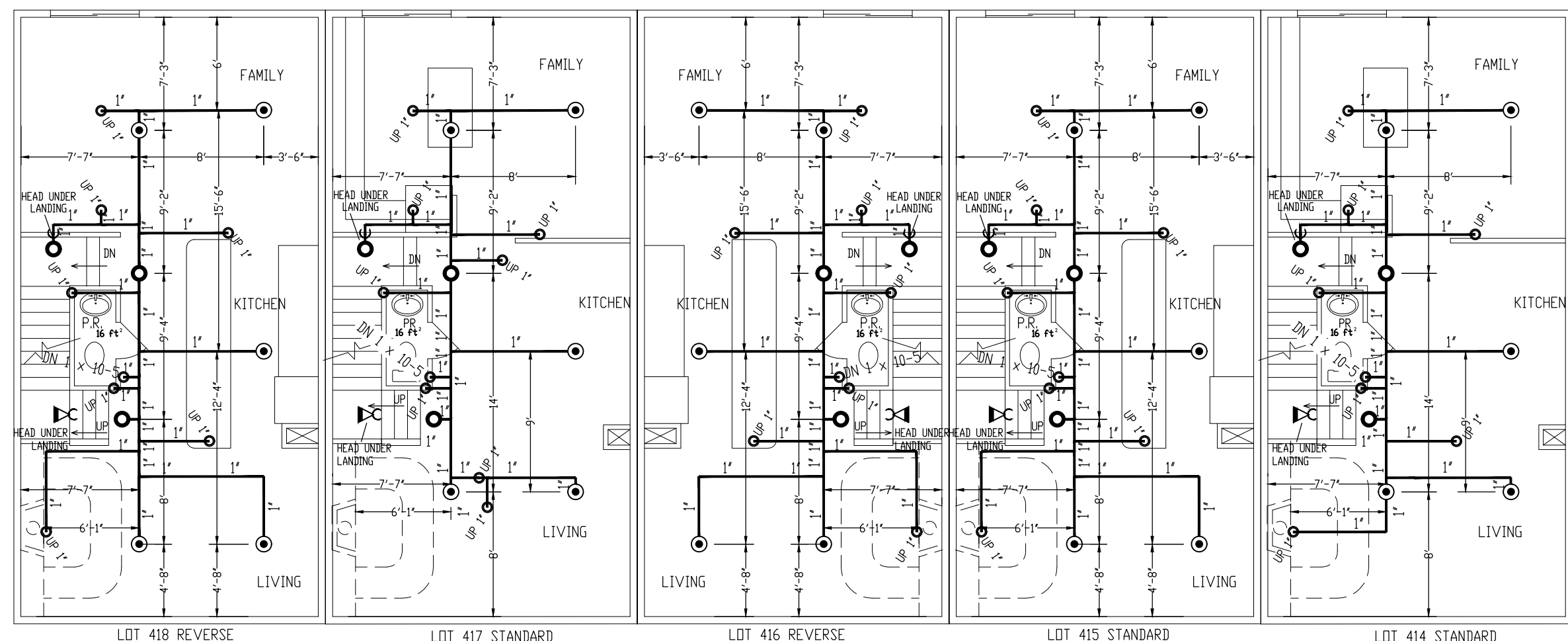
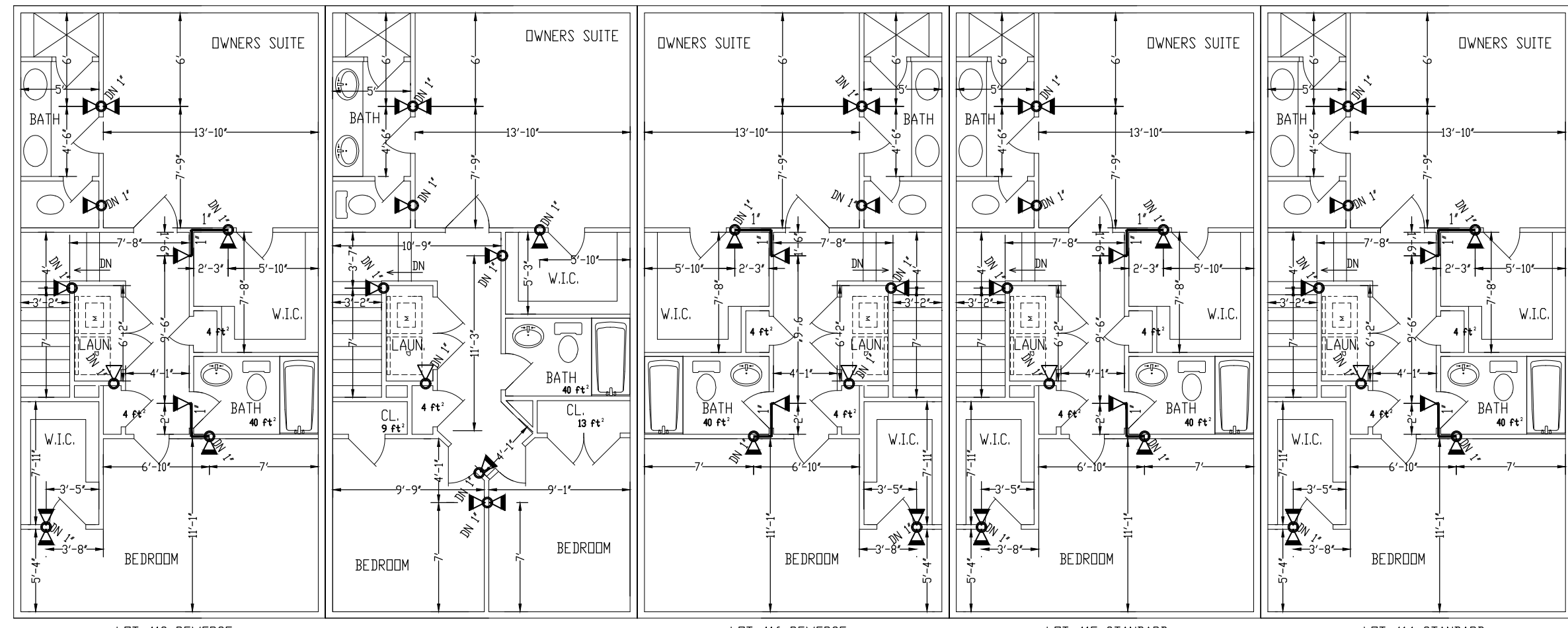

Figure 6: Sprinkler VK486 Dimensions with the Model G-1 Escutcheon



**SPRINKLER OBSTRUCTION GUIDELINES**

Table 8.2.5.4.2 Position of Sprinklers to Avoid Obstructions to Discharge (Residential Upright and Pendant Spray Sprinklers) NFPA 13D 2013

Distance From Sprinkler to Side of Obstruction (in.)	Maximum Allowable Distance of Deflector above Bottom of Obstruction (in.)
Less than 1ft	0
1 ft to less than 1 ft 6 in	0
1 ft 6 in to less than 3 ft	1
3 ft to less than 4 ft	3
4 ft to less than 4ft 6 in	5
4 ft 6 in to less than 6 ft	7
6 ft to less than 6 ft 6 in	9
6 ft 6 in to less than 7 ft	11
7 ft or more	14

For SI units, 1 in. = 25.4 mm; 1 ft = 0.3048 m.

**CPVC HANGER SPACING**

PIPE DIA.	DISTANCE BETWEEN HANGER'S
3/4"	5'-6"
1"	6'-0"
1 1/4"	6'-6"
1 1/2"	7'-0"
2"	8'-0"
2 1/2"	9'-0"
3"	10'-0"

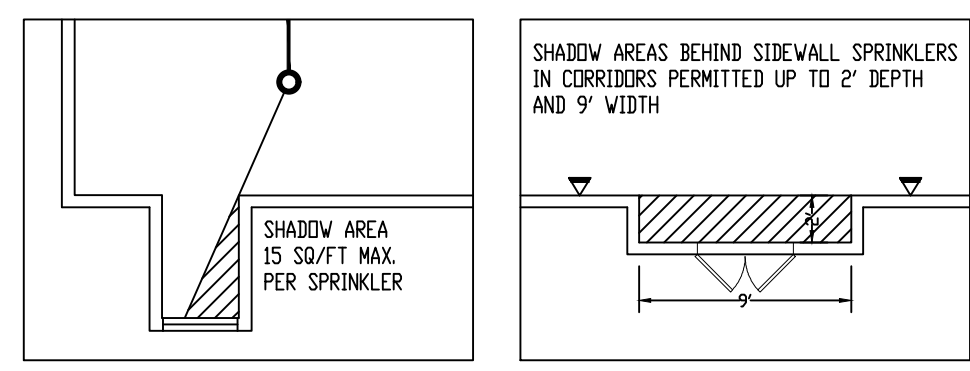
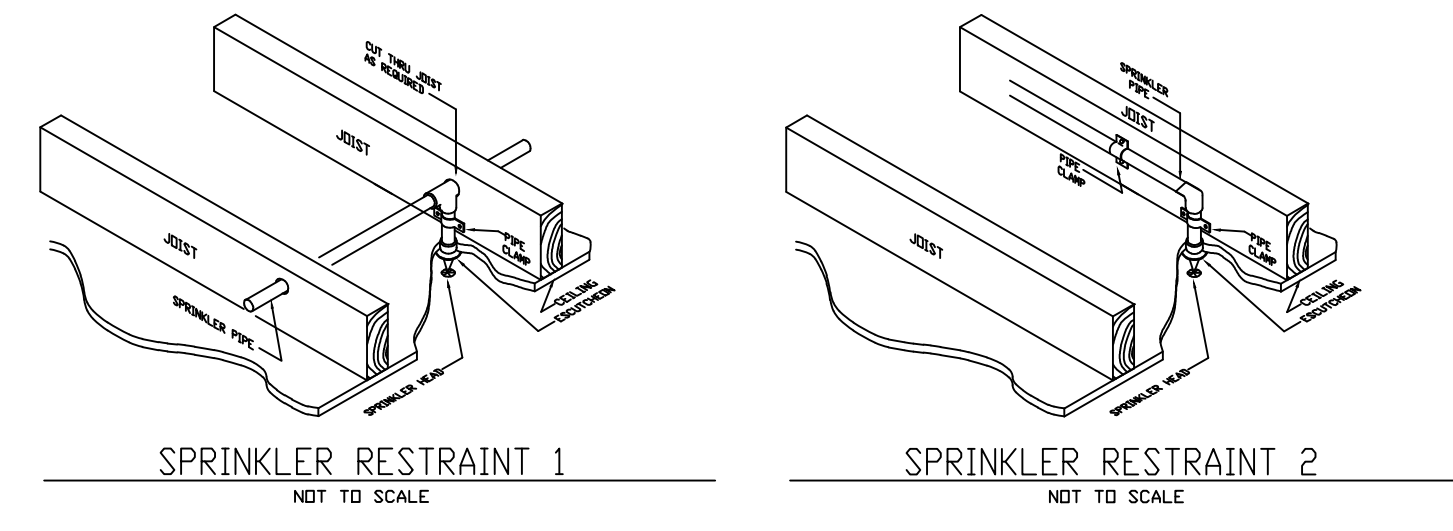

**HEAT SOURCES**  
NFPA 13D 2013

HEAT SOURCE	Minimum Distance from Edge of Source to Ordinary-Temperature Sprinkler		Minimum Distance from Edge of Source to Intermediate-Temperature Sprinkler	
	in.	mm.	in.	mm.
Side of open or recessed fireplace	36	914	12	305
Front of recessed fireplace	60	1524	36	914
Coal or wood burning stove	42	1067	12	305
Kitchen range	18	457	9	229
Wall oven	18	457	9	229
Hot air flues	18	457	9	229
uninsulated heat ducts	18	457	9	229
uninsulated hot water pipes	12	305	6	152
Side of ceiling/wall mounted hot air diffusers	24	607	12	305
Front of wall mounted hot air diffusers	36	914	18	457
Hot water heater or furnace	6	152	3	76
Light fixture DW/250W bulb	6	152	3	76
250W/499W	12	305	6	152

**SHADOW AREA DETAIL**

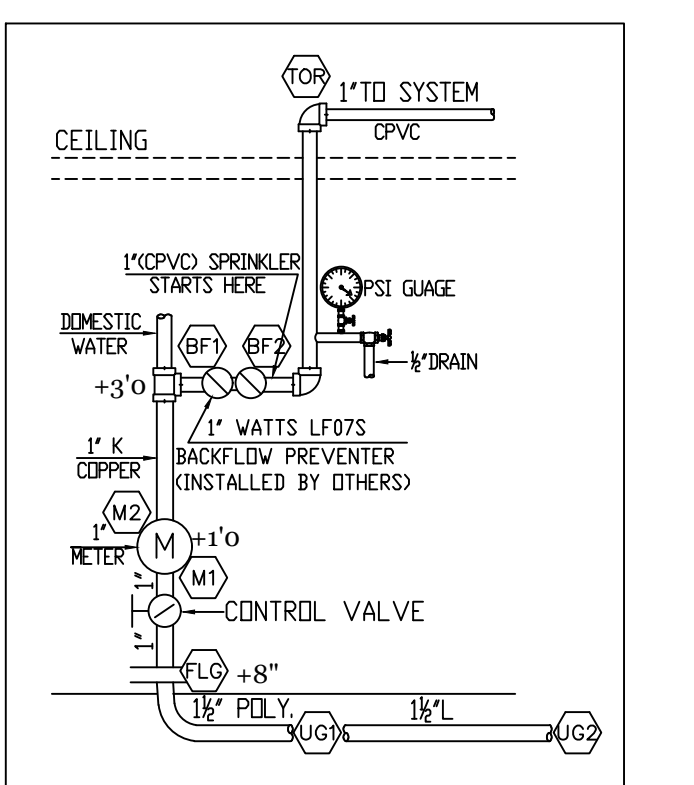

**13D MANIFOLD DETAIL**

**GENERAL NOTES**

- DWELLING UNIT SHALL HAVE A COMPLETE FIRE PROTECTION SYSTEM IN COMPLIANCE WITH STATE AND LOCAL CODES AND REGULATIONS AND N.F.P.A.-13D 2013 EDITION.
- ALL MATERIALS AND METHODS OF INSTALLATION SHALL BE IN COMPLIANCE WITH N.F.P.A.-13D
- EXPOSED SPRINKLER PIPING LOCATED IN THE ATTIC SPACE SHALL BE COVERED WITH INSULATION (R-49) PLACED OVER THE PIPING TO PREVENT FREEZING. (INSULATION BY OTHERS).
- ALL CPVC PIPE AND FITTINGS SHALL BE UL LISTED AND FM APPROVED.
- CPVC HANGER SPACING IN COMPLIANCE WITH N.F.P.A.
- ALL PIPING SHALL BE CPVC UNLESS NOTED OTHERWISE.
- NO STORAGE ROOM IN ATTIC
- UNPROTECTED CLOSETS SHALL NOT CONTAIN MECHANICAL EQUIPMENT.
- WATER METERS SHALL BE (1") IN. UNLESS OTHERWISE NOTED.
- SPRINKLER CONNECTIONS SHALL BE ON THE HOUSE SIDE OF WATER METER.
- WHEN LINTELS EXCEED 8" DEEP AND 8'-0" WIDE, ROOMS WITHIN THESE LINTELS SHALL NOT BE CONSIDERED A SINGLE COMPARTMENT. SPRINKLERS SHALL BE 16 X 16 MAXIMUM SPACING.

LOTS	HOUSE TYPE	PERMIT #	ADDRESS
414	ARCADIA	25448-2019-00	12943 BRICKYARD BLVD
415	ARCADIA	25447-2019-00	12943 BRICKYARD BLVD
416	ARCADIA	25449-2019-00	12943 BRICKYARD BLVD
417	ARCADIA	25448-2019-00	12943 BRICKYARD BLVD
418	ARCADIA	25448-2019-00	12943 BRICKYARD BLVD

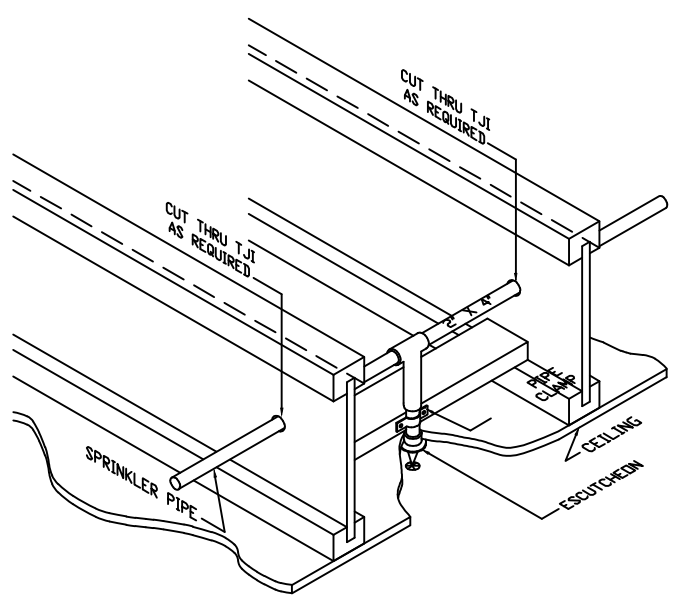

**TJI RESTRAINT**  
NOT TO SCALE

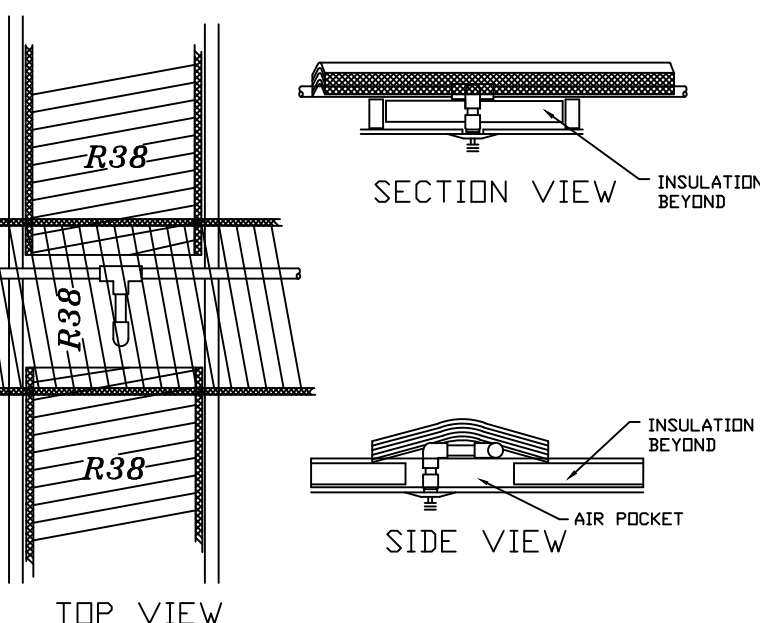

**ATTIC INSULATION DETAIL 1**  
NOT TO SCALE

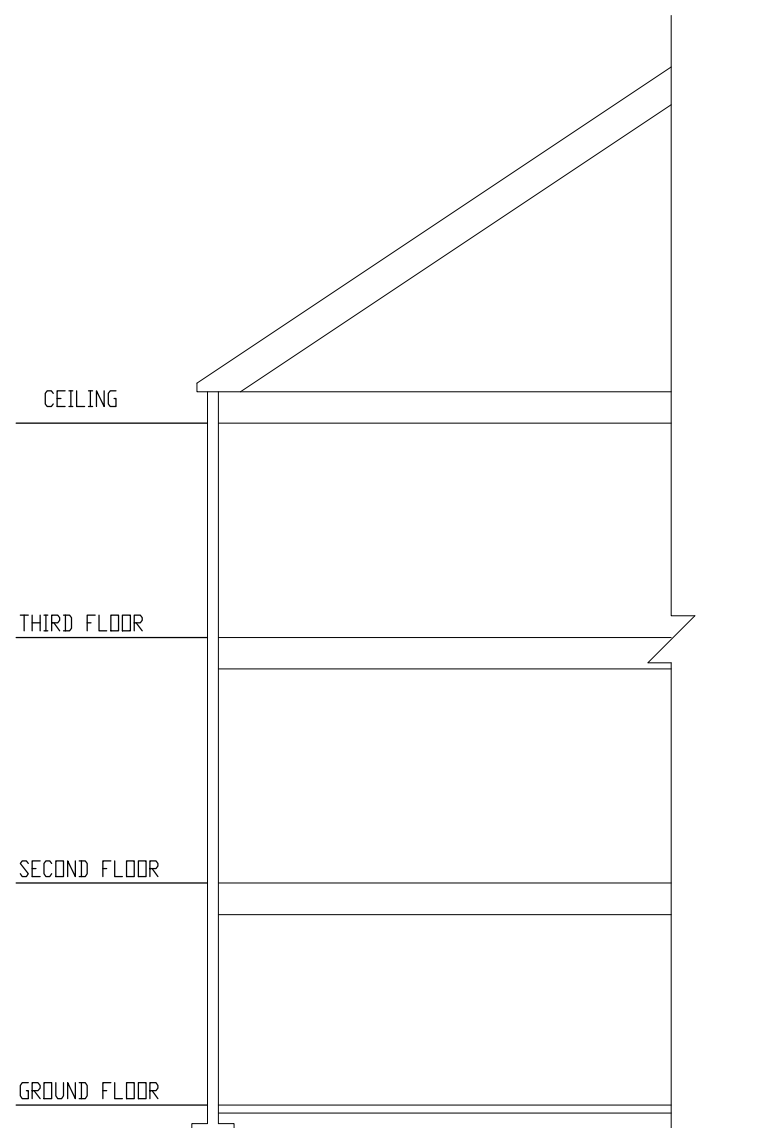

**ARCADIA ELEVATION VIEW**

**SPRINKLER SPACING**

Type	No. Head/Rm.	Spacing	Slope
Pendent	2+	16x16	8:12
Pendent	1	20x20	8:12
Sidewall	2+	16x16	8:12

TOTAL SPRINKLERS THIS DRAWING: 129

**FOREMAN NOTES:**

- CHANGES TO THIS PRINT MUST BE FOLLOWED UP WITH ASBULTS AS THEY ARE MADE AND TAKEN TO THE OFFICE.
- FOLLOW SPRINKLER SPACING SCHEDULE FOR THIS PRINT.
- FOLLOW PIPE SCHEDULE FOR THIS PRINT.
- ANY EXPOSED PIPE TO BE COPPER (M) OR STEEL SCH.10 / SCH.40 U.N.O.

**IMPORTANT**  
THIS DRAWING, THE INFORMATION, AND DESIGN APPLICATION CONTAINED HEREIN IS THE PROPERTY OF NOEL'S FIRE PROTECTION AND/OR ITS SUBSIDIARIES. ALL INFORMATION HEREIN CONTAINED SHALL BE TREATED AS CONFIDENTIAL. NO REPRODUCTION OF THIS DRAWING OR ANY PART THEREOF SHALL BE MADE WITHOUT WRITTEN CONSENT OF NOEL'S FIRE PROTECTION.

**DESIGN CRITERIA**

TYPE SYSTEM:  WET  DRY NFPA STANDARD:  #13  #13R  #130

OCCUPANCY: **Single Family Home**

HAZARD: **Light**

DENSITY: **05** GPM/S.F.

REMOTE AREA: **2ND FLRS.F.**

MAX. S.F./HD. **See Note**

HOSE REQ' MT.:  100  250  500

APPROVING AUTHORITY: **P.G. COUNTY**

PIPE SCHEDULE	PIPE SYMBOLS
1"	⊙ RISER/MANIFOLD
1 1/4"	○ ELBOW DOWN
1 1/2"	⊙ BALL VALVE
2"	⊙ REVISION

INDICATING FROM STREET

**SPRINKLER SUMMARY**

SYM	TYPE	FINISH	TEMP	ORIF.	"K"	NPT	Mfg.	MODEL#	ESCUTCHEON	QTY.	BY
⊙	RES. PEND	WHITE	155°	1/4"	4.9	1/4"	VIKING	VK468	RECESSED	40	
⊙	RES. PEND	WHITE	155°	1/4"	4.9	1/4"	VIKING	VK494	CONCEALED	25	
◁	RES. SIDEWALL	WHITE	175°	1/4"	4.0	1/4"	VIKING	VK486	RECESSED	05	
◁	RES. SIDEWALL	WHITE	155°	1/4"	4.0	1/4"	VIKING	VK486	RECESSED	59	

**REVISIONS**

DATE	DESCRIPTION	#

**NOEL'S FIRE PROTECTION**

12015 KEMPS MILL ROAD  
WILLIAMSPORT, MD 21795  
(240) 366-8287 FAX: (301) 223-8370

CONTRACTOR: **CALATLANTIC**  
14280 PARK MEADOW DRIVE  
CHANTILLY, VA 20151

PERMIT # \_\_\_\_\_ Model: TOWNS JOB #: 336D SHEET No. \_\_\_\_\_

DATE: 6-12-20 **BRICKYARD LOTS 414-418** 1  
DESIGNER: C. MONROE SEE ADDRESS BLOCK OF  
SCALE: 1/8" = 1'-0" BELTSVILLE, MD 20705 1



## TECHNICAL DATA

## FREEDOM® RESIDENTIAL PENDENT SPRINKLER VK468 (K4.9)

The Viking Corporation, 210 N Industrial Park Drive, Hastings MI 49058

Telephone: 269-945-9501 Technical Services: 877-384-5464 Fax: 269-818-1680 Email: techsvcs@vikingcorp.com

Visit the Viking website for the latest edition of this technical data page [www.vikinggroupinc.com](http://www.vikinggroupinc.com)

### 1. DESCRIPTION

Viking Freedom® Residential Pendent Sprinkler VK468 is a small, thermosensitive, glass-bulb residential sprinkler available in several different finishes and temperature ratings to meet varying design requirements. The Electroless Nickel PTFE (ENT) coating has been investigated for installation in corrosive atmospheres and is C-UL-US-EU Listed as corrosion resistant as indicated in the Approval Chart. The orifice design, with a K-Factor of 4.9 (70.6 metric†), allows efficient use of available water supplies for the hydraulically designed fire-protection system. The glass bulb operating element and special deflector characteristics meet the challenges of residential sprinkler standards.

### 2. LISTINGS AND APPROVALS



**UL Listed (C-UL-US-EU):** Category VKKW



**VdS Approved**

**NYC Approved:** MEA 89-92-E, Volume 35

**UL Classified to:** NSF/ANSI Standard 61, Drinking Water System Components (MH48034).



**WARNING:** Cancer and Reproductive Harm-  
[www.P65Warnings.ca.gov](http://www.P65Warnings.ca.gov)

Refer to the Approval Chart and Design Criteria for C-UL-US-EU Listing requirements that must be followed.

### 3. TECHNICAL DATA

#### Specifications:

Available since 2006.

Minimum Operating Pressure: Refer to the Approval Chart.

Maximum Working Pressure: 175 psi (12 bar). Factory tested hydrostatically to 500 psi (34.5 bar).

Thread size: 1/2" (15 mm) NPT

Nominal K-Factor: 4.9 U.S. (70.6 metric†)

†Metric K-factor measurement shown is in Bar. When pressure is measured in kPa, divide the metric K-factor shown by 10.0.

Glass-bulb fluid temperature rated to -65 °F (-55 °C)

Overall Length: 2-1/4" (58 mm)

#### Material Standards:

Frame Casting: Brass UNS-C84400 or QM Brass

Deflector: Brass UNS-C23000, Phosphor Bronze UNS-C51000, or Brass UNS-C26000

Bulb: Glass, nominal 3 mm diameter

Belleville Spring Sealing Assembly: Nickel Alloy, coated on both sides with Polytetrafluoroethylene (PTFE) Tape

Pip Cap and Insert Assembly: Copper UNS-C11000 and Stainless Steel UNS-S30400

Compression Screw: Brass UNS-C36000

For ENT coated sprinklers: Belleville spring - Exposed. Screw and Pipcap - ENT plated.

**Ordering Information:** (Also refer to the current Viking price list.)

**Sprinkler:** Base Part No. 13637

Order Sprinkler VK468 by first adding the appropriate suffix for the sprinkler finish and then the appropriate suffix for the temperature rating to the sprinkler base part number.

Finish Suffix: Brass = A, Chrome = F, White Polyester = M-/W, Black Polyester = M-/B, and ENT = JN

Temperature Suffix: 155 °F (68 °C) = B, 175 °F (79 °C) = D

For example, sprinkler VK468 with a Brass finish and a 155 °F (68 °C) temperature rating = Part No. 13637AB.

#### Available Finishes And Temperature Ratings:

Refer to Table 1.

**Accessories:** (Also refer to the Viking website.)

#### Sprinkler Wrenches:

A. Standard Wrench: Part No. 21475M/B (available since 2017)

B. Wrench for recessed sprinklers: Part No. 13577W/B\* (available since 2006)

C. Optional Protective Sprinkler Cap Remover/Escutcheon Installer Tool\*\* Part No. 15915 (available since 2010.)

\*A 1/2" ratchet is required (not available from Viking).

\*\*Allows use from the floor by attaching a length of 1" diameter CPVC tubing to the tool. Ideal for sprinkler cabinets. Refer to Bulletin F\_051808.

	<b>TECHNICAL DATA</b>	<b>FREEDOM® RESIDENTIAL PENDENT SPRINKLER VK468 (K4.9)</b>
---	-----------------------	--

**The Viking Corporation, 210 N Industrial Park Drive, Hastings MI 49058**  
**Telephone: 269-945-9501 Technical Services: 877-384-5464 Fax: 269-818-1680 Email: techsvcs@vikingcorp.com**  
**Visit the Viking website for the latest edition of this technical data page [www.vikinggroupinc.com](http://www.vikinggroupinc.com)**

**Sprinkler Cabinets:**

- A. Six-head capacity: Part No. 01724A (available since 1971)
- B. Twelve-head capacity: Part No. 01725A (available since 1971)

**4. INSTALLATION**

Refer to appropriate NFPA Installation Standards.

**5. OPERATION**

During fire conditions, the heat-sensitive liquid in the glass bulb expands, causing the glass to shatter, releasing the pip cap and sealing spring assembly. Water flowing through the sprinkler orifice strikes the sprinkler deflector, forming a uniform spray pattern to extinguish or control the fire.

**6. INSPECTIONS, TESTS AND MAINTENANCE**

Refer to NFPA 25 for Inspection, Testing and Maintenance requirements.

**7. AVAILABILITY**

The Viking Model VK468 Sprinkler is available through a network of domestic and international distributors. See The Viking Corporation web site for the closest distributor or contact The Viking Corporation.

**8. GUARANTEE**

For details of warranty, refer to Viking's current list price schedule or contact Viking directly.

**TABLE 1: AVAILABLE SPRINKLER TEMPERATURE RATINGS AND FINISHES**

Sprinkler Temperature Classification	Sprinkler Nominal Temperature Rating <sup>1</sup>	Maximum Ambient Ceiling Temperature <sup>2</sup>	Bulb Color
Ordinary	155 °F (68 °C)	100 °F (38 °C)	Red
Intermediate	175 °F (79 °C)	150 °F (65 °C)	Yellow

**Sprinkler Finishes:** Brass, Chrome, White Polyester, Black Polyester, and ENT

**Corrosion Resistant Coatings<sup>3</sup>:** ENT

**Footnotes**

- <sup>1</sup> The sprinkler temperature rating is stamped on the deflector.
- <sup>2</sup> Based on NFPA-13. Other limits may apply, depending on fire loading, sprinkler location, and other requirements of the Authority Having Jurisdiction. Refer to specific installation standards.
- <sup>3</sup> The corrosion resistant coatings have passed the standard corrosion test required by the approving agencies indicated in the Approval Chart. These tests cannot and do not represent all possible corrosive environments. Prior to installation, verify through the end-user that the coatings are compatible with or suitable for the proposed environment. For ENT coated sprinklers, the waterway is coated. Note that the spring is exposed on sprinklers with ENT coating.

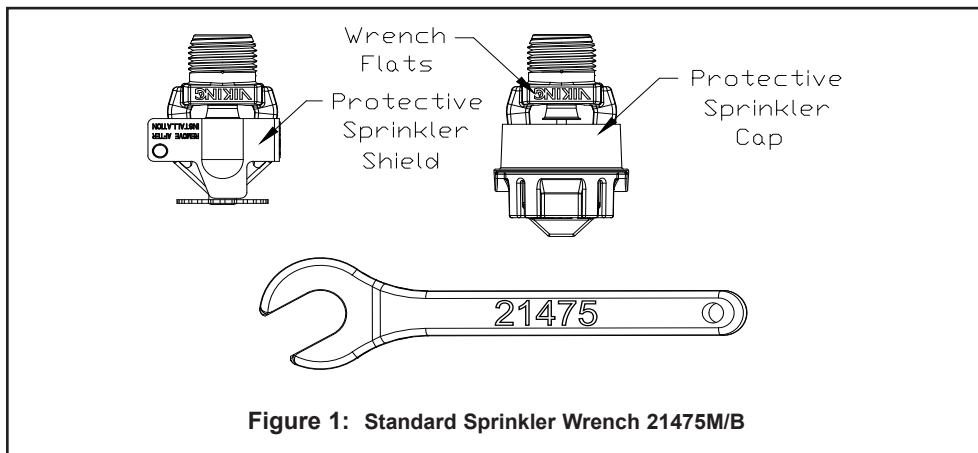

**Figure 1: Standard Sprinkler Wrench 21475M/B**



## TECHNICAL DATA

## FREEDOM® RESIDENTIAL PENDENT SPRINKLER VK468 (K4.9)

The Viking Corporation, 210 N Industrial Park Drive, Hastings MI 49058  
 Telephone: 269-945-9501 Technical Services: 877-384-5464 Fax: 269-818-1680 Email: techsvcs@vikingcorp.com  
 Visit the Viking website for the latest edition of this technical data page www.vikinggroupinc.com

### Approval Chart Viking VK468, 4.9 K-Factor Residential Pendent Sprinkler

For systems designed to NFPA 13D or NFPA 13R. For systems designed to NFPA 13, refer to the design criteria. For Ceiling types refer to current editions of NFPA 13, 13R or 13D

Sprinkler Base Part Number <sup>1</sup>	SIN	NPT Thread Size		Nominal K-Factor		Maximum Water Working Pressure	Overall Length				
		Inches	mm	U.S.	metric <sup>2</sup>		Inches	mm			
13637	VK468	1/2	15	4.9	70.6	175 psi (12 bar)	2-1/4	58			
Max. Coverage Area <sup>4</sup> Ft.X Ft. (m X m)	Ordinary Temp Rating (155 °F/68 °C)		Intermediate Temp Rating (175 °F/79 °C)		Deflector to Ceiling	Installation Type	Listings and Approvals <sup>3</sup>				Minimum Spacing Ft. (m)
	Flow <sup>4</sup> GPM (L/min)	Pressure <sup>4</sup> PSI (bar)	Flow <sup>4</sup> GPM (L/min)	Pressure <sup>4</sup> PSI (bar)			C-UL-US-EU <sup>5</sup>	VdS	NYC <sup>6</sup>	NSF <sup>8</sup>	
12 X 12 (3.7 X 3.7)	13 (49.2)	7.0 (0.48)	13 (49.2)	7.0 (0.48)	1-1/8 to 2 inch	Standard surface-mounted escutcheons, or recessed with the Micromatic® Model E-1, E-2, or E-3 Recessed Escutcheon	See Foot-notes 7 and 10.	See Foot-notes 7 and 10.	See Foot-note 7.	See Foot-note 7.	8 (2.4)
14 X 14 (4.3 X 4.3)	13 (49.2)	7.0 (0.48)	13 (49.2)	7.0 (0.48)							
16 X 16 (4.9 X 4.9)	13 (49.2)	7.0 (0.48)	13 (49.2)	7.0 (0.48)							
18 X 18 (5.5 X 5.5)	17 (64.4)	12.0 (0.83)	17 (64.4)	12.0 (0.83)							
20 X 20 (6.1 X 6.1)	20 (75.7)	16.7 (1.15)	20 (75.7)	16.7 (1.15)							

#### Footnotes

- <sup>1</sup> Part number shown is the base part number. For complete part number, refer to Viking's current price schedule.
- <sup>2</sup> Metric K-factor measurement shown is when pressure is measured in Bar. When pressure is measured in kPa, divide the metric K-factor shown by 10.0.
- <sup>3</sup> This chart shows the listings and approvals available at the time of printing. Other approvals may be in process. Check with the manufacturer for any additional approvals. Refer also to Design Criteria.
- <sup>4</sup> For areas of coverage smaller than shown, use the "Flow" and "Pressure" for the next larger area listed. Flows and pressures listed are per sprinkler. The distance from sprinklers to walls shall not exceed one-half the sprinkler spacing indicated for the minimum "Flow" and "Pressure" used.
- <sup>5</sup> Listed by Underwriter's Laboratories, Inc. for use in the U.S., Canada, and European Union.
- <sup>6</sup> Accepted for use, City of New York Department of Buildings, MEA Number 89-92-E, Vol. 35.
- <sup>7</sup> Approved Finishes are: Brass, Chrome, White Polyester, and Black Polyester<sup>9</sup>
- <sup>8</sup> UL Classified to: NSF/ANSI Standard 61, Drinking Water System Components (MH48034).
- <sup>9</sup> Other paint colors are available on request with the same C-UL-US-EU listings as the standard finish colors.
- <sup>10</sup> Approved finish is Electroless Nickel PTFE (ENT). ENT is C-UL-US-EU Listed as corrosion resistant. ENT is available with standard surface-mounted escutcheons or the Micromatic Model E-1 Recessed Escutcheon.



TECHNICAL DATA

FREEDOM® RESIDENTIAL  
PENDENT SPRINKLER  
VK468 (K4.9)

The Viking Corporation, 210 N Industrial Park Drive, Hastings MI 49058  
 Telephone: 269-945-9501 Technical Services: 877-384-5464 Fax: 269-818-1680 Email: techsvcs@vikingcorp.com  
 Visit the Viking website for the latest edition of this technical data page www.vikinggroupinc.com

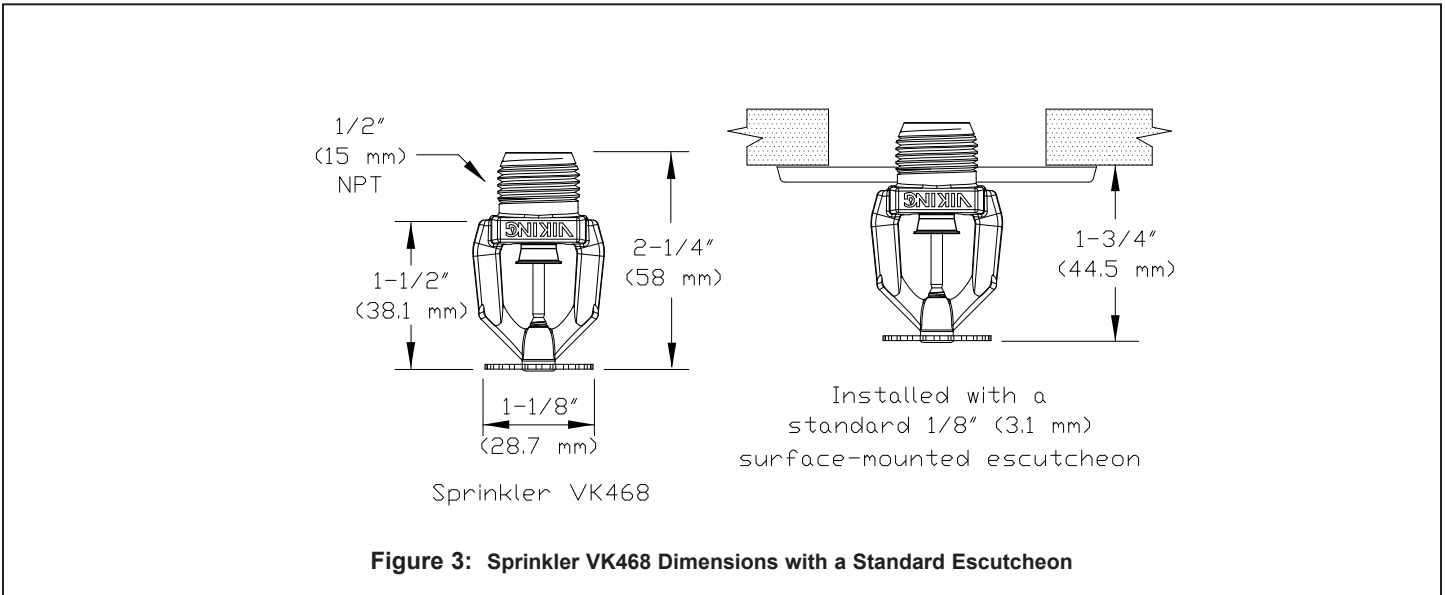
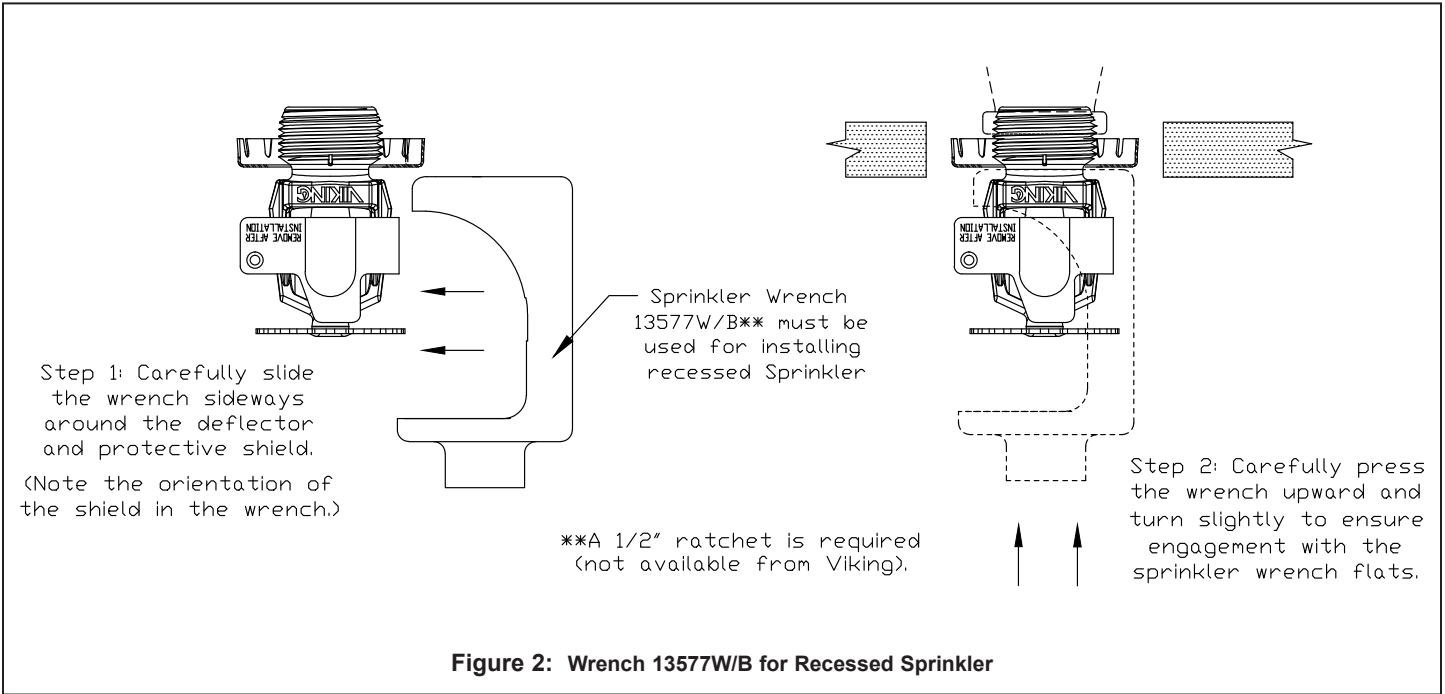



## TECHNICAL DATA

## FREEDOM® RESIDENTIAL PENDENT SPRINKLER VK468 (K4.9)

The Viking Corporation, 210 N Industrial Park Drive, Hastings MI 49058

Telephone: 269-945-9501 Technical Services: 877-384-5464 Fax: 269-818-1680 Email: techsvcs@vikingcorp.com

Visit the Viking website for the latest edition of this technical data page [www.vikinggroupinc.com](http://www.vikinggroupinc.com)

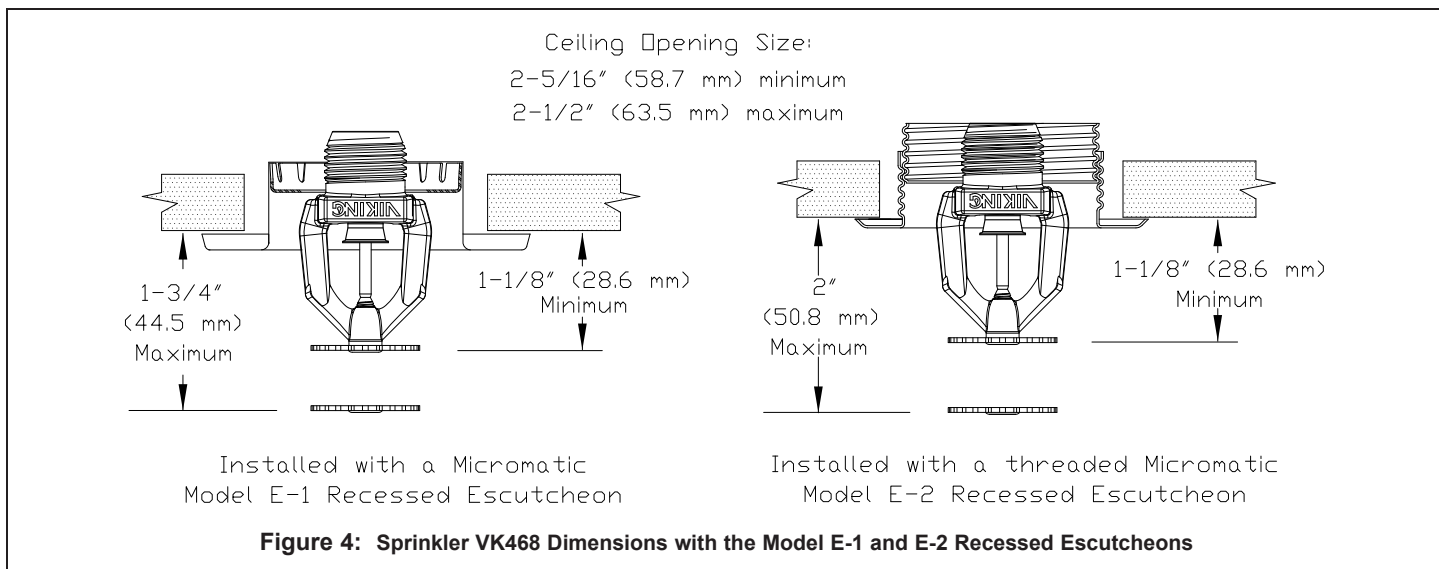

### DESIGN CRITERIA

(Also refer to the Approval Chart.)

#### UL Listing Requirements (C-UL-US-EU):

When using Viking Residential Pendent Sprinkler VK468 for systems designed to NFPA 13D or NFPA 13R, apply the listed areas of coverage and minimum water supply requirements shown in the Approval Chart.

For systems designed to NFPA 13: The number of design sprinklers is to be the four contiguous most hydraulically demanding sprinklers. The minimum required discharge from each of the four sprinklers is to be the greater of the following:

- The flow rates given in the Approval Chart for NFPA 13D and NFPA13R applications for each listed area of coverage, **or**
- Calculated based on a minimum discharge of 0.1 gpm/sq. ft. over the "design area" in accordance with sections 8.5.2.1 or 8.6.2.1.2 of NFPA 13.
- Minimum distance between residential sprinklers: 8 ft. (2.4 m).

**IMPORTANT:** Always refer to Bulletin Form No. F\_091699 - Care and Handling of Sprinklers. Also refer to Form No. F\_080614, F\_080415 and F\_080190 for general care, installation, and maintenance information. Viking sprinklers are to be installed in accordance with the latest edition of Viking technical data, the appropriate standards of NFPA, VdS, and any other similar Authorities Having Jurisdiction, and also with the provisions of governmental codes, ordinances, and standards, whenever applicable. Final approval and acceptance of all residential sprinkler installations must be obtained from the Authorities Having Jurisdiction.



## TECHNICAL DATA

## FREEDOM® RESIDENTIAL HORIZONTAL SIDEWALL SPRINKLER VK486 (K4.0)

The Viking Corporation, 210 N Industrial Park Drive, Hastings MI 49058

Telephone: 269-945-9501 Technical Services: 877-384-5464 Fax: 269-818-1680 Email: techsvcs@vikingcorp.com

Visit the Viking website for the latest edition of this technical data page: [www.vikinggroupinc.com](http://www.vikinggroupinc.com)

### 1. DESCRIPTION

Viking Freedom® Residential Horizontal Sidewall Sprinkler VK486 is a small, thermostatic, glass-bulb residential sprinkler available in several different finishes and temperature ratings to meet varying design requirements. The Electroless Nickel PTFE (ENT) coating has been investigated for installation in corrosive atmospheres and is C-UL-US-EU Listed as corrosion resistant as indicated in the Approval Chart. The sprinkler orifice design, with a K-Factor of 4.0 (57.7 metric†), allows efficient use of available water supplies for the hydraulically designed fire-protection system. The glass bulb operating element and special deflector characteristics meet the challenges of residential sprinkler standards.

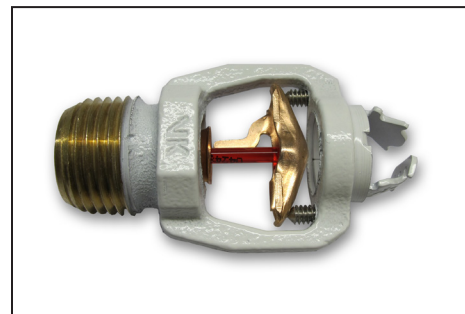

### 2. LISTINGS AND APPROVALS

 **UL Listed (C-UL-US-EU):** Category VKKW

 **VdS Approved**

 **WARNING:** Cancer and Reproductive Harm-  
[www.P65Warnings.ca.gov](http://www.P65Warnings.ca.gov)

Refer to the Approval Chart and Design Criteria for C-UL-US-EU Listing requirements that must be followed.

### 3. TECHNICAL DATA

#### Specifications:

Available since 2011.

Minimum Operating Pressure: Refer to the Approval Chart.

Maximum Working Pressure: 175 psi (12 bar). Factory tested hydrostatically to 500 psi (34.5 bar).

Thread size: 1/2" (15 mm) NPT

Nominal K-Factor: 4.0 U.S. (57.7 metric†)

† Metric K-factor measurement shown is in Bar. When pressure is measured in kPa, divide the metric K-factor shown by 10.0.

Glass-bulb fluid temperature rated to -65 °F (-55 °C)

Overall Length: 2-7/16" (62 mm)

Covered by the following US Patent numbers: 7,854,269 and 7,712,218

#### Material Standards:

Frame Casting: QM Brass and Brass UNS-C84400

Deflector: Phosphor Bronze UNS-C51000

Bulb: Glass, nominal 3 mm diameter

Belleville Spring Sealing Assembly: Nickel Alloy, coated on both sides with PTFE Tape

Pip Cap and Insert Assembly: Copper UNS-C11000 and Stainless Steel UNS-S30400

Compression Screws: 18-8 Stainless Steel

Yoke: Phosphor Bronze UNS-C51000

**Ordering Information:** (Also refer to the current Viking price list.)

**Sprinkler:** Base Part No. 17315

Order Sprinkler VK486 by first adding the appropriate suffix for the sprinkler finish and then the appropriate suffix for the temperature rating to the sprinkler base part number.

Finish Suffix: Brass = A, Chrome = F, White Polyester = M-/W, Black Polyester = M-/B

Temperature Suffix: 155 °F (68 °C) = B, 175 °F (79 °C) = D

For example, sprinkler VK486 with a Brass finish and a 155 °F (68 °C) temperature rating = Part No. 17315AB.

#### Available Finishes And Temperature Ratings:

Refer to Table 1.

**Accessories:** (Also refer to the Viking website.)

#### Sprinkler Wrenches:

A. Standard Wrench: Part No. 21475M/B (available since 2017)

B. Wrench for recessed sprinklers: Part No. 13655W/B\* (available since 2006)

\*A 1/2" ratchet is required (not available from Viking).





**TECHNICAL DATA**

**FREEDOM® RESIDENTIAL HORIZONTAL SIDEWALL SPRINKLER VK486 (K4.0)**

The Viking Corporation, 210 N Industrial Park Drive, Hastings MI 49058  
 Telephone: 269-945-9501 Technical Services: 877-384-5464 Fax: 269-818-1680 Email: techsvcs@vikingcorp.com  
 Visit the Viking website for the latest edition of this technical data page: www.vikinggroupinc.com

**Sprinkler Cabinets:**

- A. Six-head capacity: Part No. 01724A (available since 1971)
- B. Twelve-head capacity: Part No. 01725A (available since 1971)

**4. INSTALLATION**

Refer to appropriate NFPA Installation Standards.

**5. OPERATION**

During fire conditions, the heat-sensitive liquid in the glass bulb expands, causing the glass to shatter, releasing the yoke, pip cap, and sealing spring assembly. Water flowing through the sprinkler orifice strikes the sprinkler deflector, forming a uniform spray pattern to extinguish or control the fire.

**6. INSPECTIONS, TESTS AND MAINTENANCE**

Refer to NFPA 25 for Inspection, Testing and Maintenance requirements.

**7. AVAILABILITY**

Viking Sprinkler VK486 is available through a network of domestic and international distributors. See The Viking Corporation web site for the closest distributor or contact The Viking Corporation.

**8. GUARANTEE**

For details of warranty, refer to Viking's current list price schedule or contact Viking directly.

**TABLE 1: AVAILABLE SPRINKLER TEMPERATURE RATINGS AND FINISHES**

Sprinkler Temperature Classification	Sprinkler Nominal Temperature Rating <sup>1</sup>	Maximum Ambient Ceiling Temperature <sup>2</sup>	Bulb Color
Ordinary	155 °F (68 °C)	100 °F (38 °C)	Red
Intermediate	175 °F (79 °C)	150 °F (65 °C)	Yellow

**Sprinkler Finishes:** Brass, Chrome, White Polyester, and Black Polyester.

**Footnotes**

<sup>1</sup> The sprinkler temperature rating is stamped on the deflector.

<sup>2</sup> Based on NFPA-13. Other limits may apply, depending on fire loading, sprinkler location, and other requirements of the Authority Having Jurisdiction. Refer to specific installation standards.

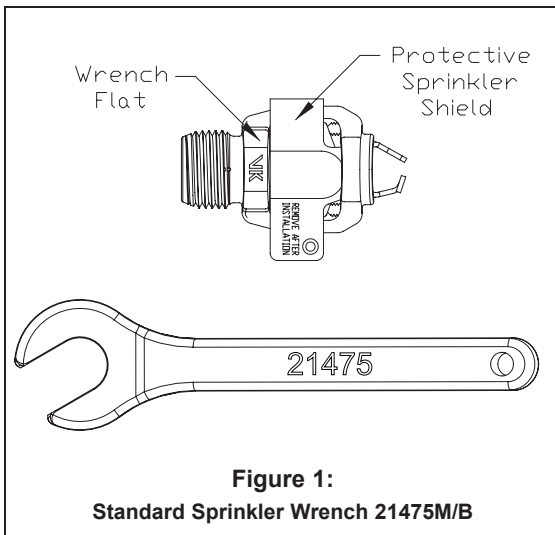

**Figure 1:**  
Standard Sprinkler Wrench 21475M/B

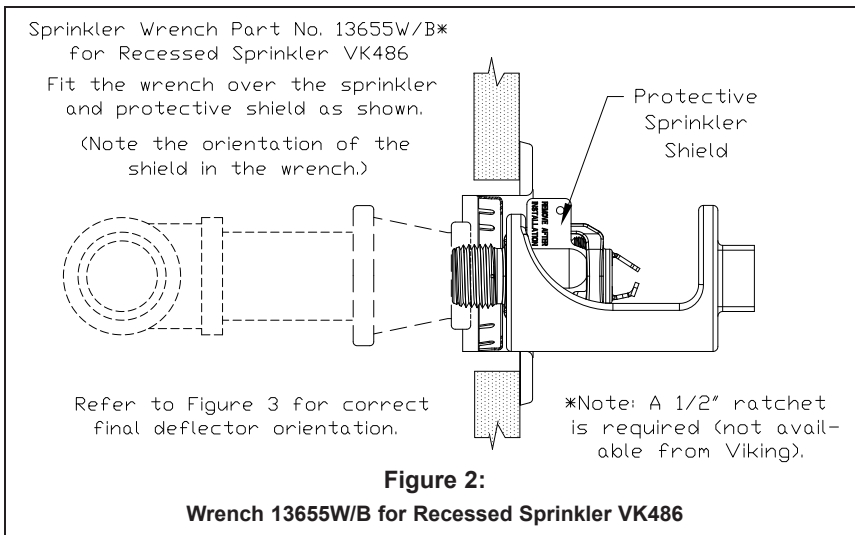

**Figure 2:**  
Wrench 13655W/B for Recessed Sprinkler VK486



## TECHNICAL DATA

## FREEDOM® RESIDENTIAL HORIZONTAL SIDEWALL SPRINKLER VK486 (K4.0)

The Viking Corporation, 210 N Industrial Park Drive, Hastings MI 49058  
 Telephone: 269-945-9501 Technical Services: 877-384-5464 Fax: 269-818-1680 Email: techsvcs@vikingcorp.com  
 Visit the Viking website for the latest edition of this technical data page: www.vikinggroupinc.com

### Approval Chart Viking VK486, 4.0 K-Factor Residential Horizontal Sidewall Sprinkler

For systems designed to NFPA 13D or NFPA 13R. For systems designed to NFPA 13, refer to the design criteria. For Ceiling types refer to current Editions of NFPA 13, 13R or 13D

Sprinkler Base Part Number <sup>1</sup>	SIN	NPT Thread Size		Nominal K-Factor		Maximum Water Working Pressure	Overall Length					
		Inches	mm	U.S.	metric <sup>2</sup>		Inches	mm				
17315	VK486	1/2	15	4.0	57.7	175 psi (12 bar)	2-7/16		62			
Max. Coverage Area <sup>3</sup> Width X Length Ft. X Ft. (m X m)	Max. Spacing Ft. (m)	Ordinary Temp Rating (155 °F/68 °C)		Intermediate Temp Rating (175 °F/79 °C)		Top of Deflector to Ceiling	Installation Type	Listings and Approvals <sup>4</sup>				Minimum Spacing Ft. (m)
		Flow <sup>3</sup> GPM (L/min)	Pressure <sup>3</sup> PSI (bar)	Flow <sup>3</sup> GPM (L/min)	Pressure <sup>3</sup> PSI (bar)			C-UL-US-EU <sup>5</sup>	VdS	NYC	NSF <sup>9</sup>	
12 X 12 (3.7 X 3.7)	12 (3.7)	11 (41.7)	7.6 (0.52)	11 (41.7)	7.6 (0.52)	4 to 6 inches	Standard surface-mounted escutcheons or recessed with the Micromatic® Model E-1, E-2, E-3, or G-1 Recessed Escutcheon	See Footnote 6 and 10.	See Footnote 6.	See Footnote 7.	See Footnote 6.	8 (2.4)
14 X 14 (4.3 X 4.3)	14 (4.3)	12 (45.5)	9 (0.62)	12 (45.5)	9 (0.62)							
16 X 16 (4.9 X 4.9)	16 (4.9)	13 (49.3)	10.6 (0.73)	13 (49.3)	10.6 (0.73)							
16 X 18 (4.9 X 5.5)	16 (4.9)	16 (60.6)	16 (1.10)	16 (60.6)	16 (1.10)							
16 X 20 (4.9 X 6.1)	16 (4.9)	22 (83.3)	30.3 (2.09)	22 (83.3)	30.3 (2.09)							
16 X 22 (4.9 X 6.7)	16 (4.9)	24 (90.8)	36 (2.48)	24 (90.8)	36 (2.48)							
18 X 18 (5.5 X 5.5)	18 (5.5)	18 (68.1)	20.3 (1.40)	19 (71.9)	22.6 (1.60)							
18 X 20 (5.5 X 6.1)	18 (5.5)	22 (83.3)	30.3 (2.09)	22 (83.3)	30.3 (2.09)							
20 X 20 (6.1 X 6.1)	20 (6.1)	22 (83.3)	30.3 (2.09)	22 (83.3)	30.3 (2.09)	6 to 12 inches						
12 X 12 (3.7 X 3.7)	12 (3.7)	12 (45.5)	9 (0.62)	12 (45.5)	9 (0.62)							
14 X 14 (4.3 X 4.3)	14 (4.3)	12 (45.5)	9 (0.62)	13 (49.3)	10.6 (0.73)							
16 X 16 (4.9 X 4.9)	16 (4.9)	14 (53.0)	12.3 (0.84)	14 (53.0)	12.3 (0.84)							
16 X 18 (4.9 X 5.5)	16 (4.9)	16 (60.6)	16 (1.10)	16 (60.6)	16 (1.10)							
16 X 20 (4.9 X 6.1)	16 (4.9)	23 (87.1)	33.1 (2.28)	23 (87.1)	33.1 (2.28)							
16 X 22 (4.9 X 6.7)	16 (4.9)	26 (98.4)	42.3 (2.91)	26 (98.4)	42.3 (2.91)							
18 X 18 (5.5 X 5.5)	18 (5.5)	18 (68.1)	20.3 (1.40)	19 (71.9)	22.6 (1.60)							
18 X 20 (5.5 X 6.1)	18 (5.5)	23 (87.1)	33.1 (2.28)	23 (87.1)	33.1 (2.28)							
20 X 20 (6.1 X 6.1)	20 (6.1)	24 (90.8)	36 (2.48)	24 (90.8)	36 (2.48)							

#### Footnotes

- Part number shown is the base part number. For complete part number, refer to Viking's current price schedule.
- Metric K-factor measurement shown is when pressure is measured in Bar. When pressure is measured in kPa, divide the metric K-factor shown by 10.0.
- For areas of coverage smaller than shown, use the "Flow" and "Pressure" for the next larger area listed. Flows and pressures listed are per sprinkler. The distance from sprinklers to walls shall not exceed one-half the sprinkler spacing indicated for the minimum "Flow" and "Pressure" used.
- This chart shows the listings and approvals available at the time of printing. Other approvals may be in process. Check with the manufacturer for any additional approvals. Refer also to Design Criteria.
- Listed by Underwriter's Laboratories, Inc. for use in the U.S., Canada, and European Union.
- Approved Finishes are: Brass, Chrome, White Polyester, and Black Polyester <sup>8</sup>
- Meets New York City requirements, effective July 1, 2008.
- Other paint colors are available on request with the same C-UL-US-EU listings as the standard finish colors.
- UL Classified to : NSF/ANSI Standard 61, Drinking Water System Components (MH48034)
- Approved finish is Electroless Nickel PTFE (ENT). ENT is C-UL-US-EU Listed as corrosion resistant. ENT is available with standard surface-mounted escutcheons or the Micromatic Model E-1 Recessed Escutcheon.



**TECHNICAL DATA**

**FREEDOM® RESIDENTIAL HORIZONTAL SIDEWALL SPRINKLER VK486 (K4.0)**

The Viking Corporation, 210 N Industrial Park Drive, Hastings MI 49058  
 Telephone: 269-945-9501 Technical Services: 877-384-5464 Fax: 269-818-1680 Email: techsvcs@vikingcorp.com  
 Visit the Viking website for the latest edition of this technical data page: www.vikinggroupinc.com

**DESIGN CRITERIA**

(Also refer to the Approval Chart.)

**UL Listing Requirements (C-UL-US-EU):**

When using Viking Residential Horizontal Sidewall Sprinkler VK486 for systems designed to NFPA 13D or NFPA 13R, apply the listed areas of coverage and minimum water supply requirements shown in the Approval Chart.

For systems designed to NFPA 13: The number of design sprinklers is to be the four contiguous most hydraulically demanding sprinklers. The minimum required discharge from each of the four sprinklers is to be the greater of the following:

- The flow rates given in the Approval Chart for NFPA 13D and NFPA 13R applications for each listed area of coverage, **or**
- Calculated based on a minimum discharge of 0.1 gpm/sq. ft. over the “design area” in accordance with sections 8.5.2.1 or 8.6.2.1.2 of NFPA 13.
- Minimum distance between residential sprinklers: 8 ft. (2.4 m).
- The VK486 horizontal sidewall sprinkler deflector shall be located a minimum of 1-1/4” (31.8 mm) and a maximum of 6” (152 mm) from the wall on which it is installed.

**DEFLECTOR POSITION:** Install sprinkler VK486 with the leading edge of the deflector oriented parallel to the ceiling and the sprinkler frame arms oriented perpendicular to the ceiling (see Figure 4). **THE TOP SURFACE OF THE DEFLECTOR IS MARKED “TOP”.** The sprinkler must be oriented as shown in Figure 3 below.

**IMPORTANT: Always refer to Bulletin Form No. F\_091699 - Care and Handling of Sprinklers. Also refer to Form No. F\_080190, F\_080814, and F\_080415 for general care, installation, and maintenance information. Viking sprinklers are to be installed in accordance with the latest edition of Viking technical data, the appropriate standards of NFPA and any other similar Authorities Having Jurisdiction, and also with the provisions of governmental codes, ordinances, and standards, whenever applicable. Final approval and acceptance of all residential sprinkler installations must be obtained from the Authorities Having Jurisdiction.**

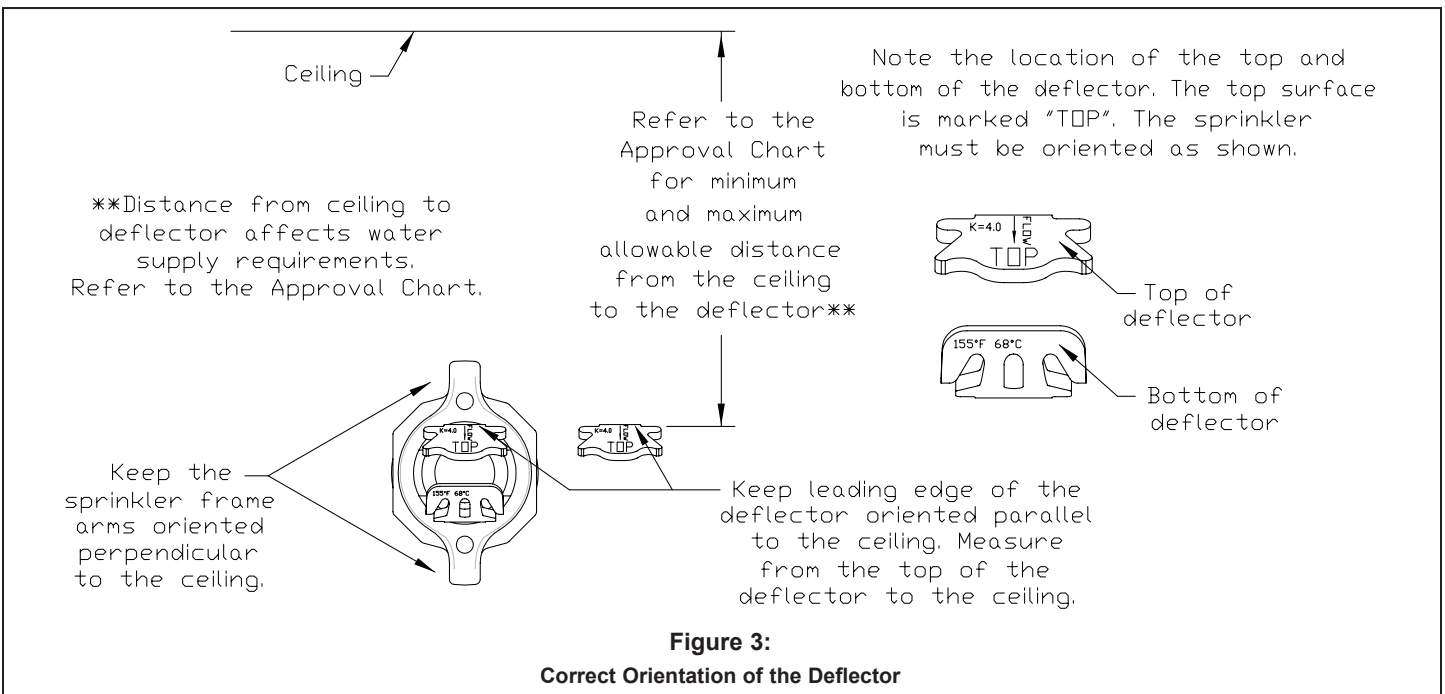



**TECHNICAL DATA**

**FREEDOM® RESIDENTIAL  
HORIZONTAL SIDEWALL  
SPRINKLER VK486 (K4.0)**

The Viking Corporation, 210 N Industrial Park Drive, Hastings MI 49058  
 Telephone: 269-945-9501 Technical Services: 877-384-5464 Fax: 269-818-1680 Email: techsvcs@vikingcorp.com  
 Visit the Viking website for the latest edition of this technical data page: www.vikinggroupinc.com

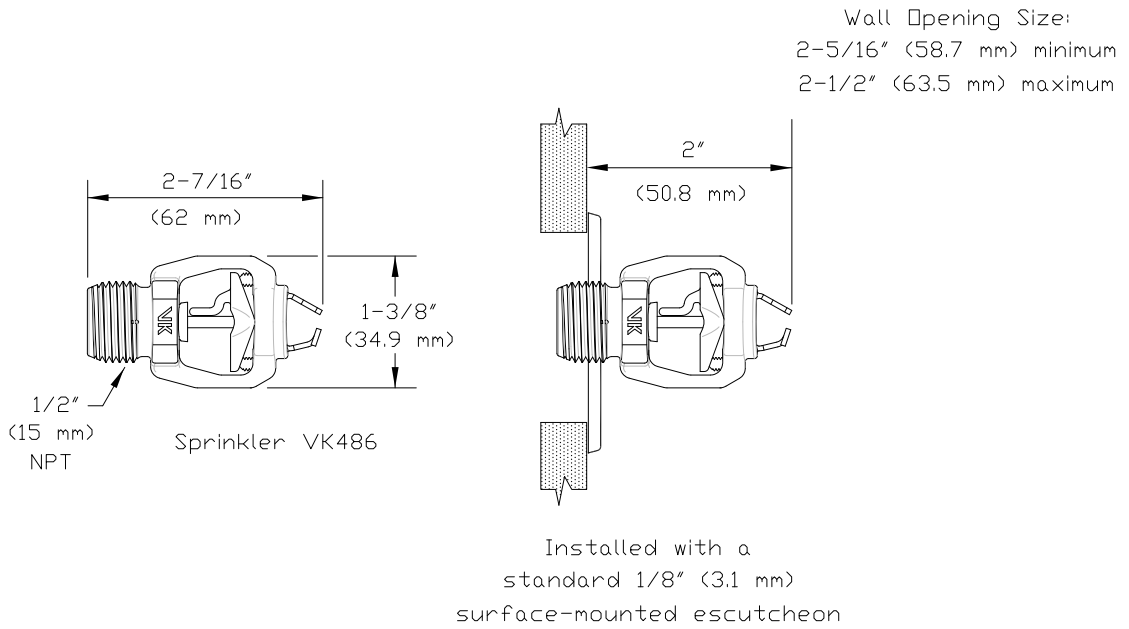

**Figure 4:**  
**Sprinkler VK486 Dimensions with a Standard Escutcheon and the Model F-1 Adjustable Escutcheon**

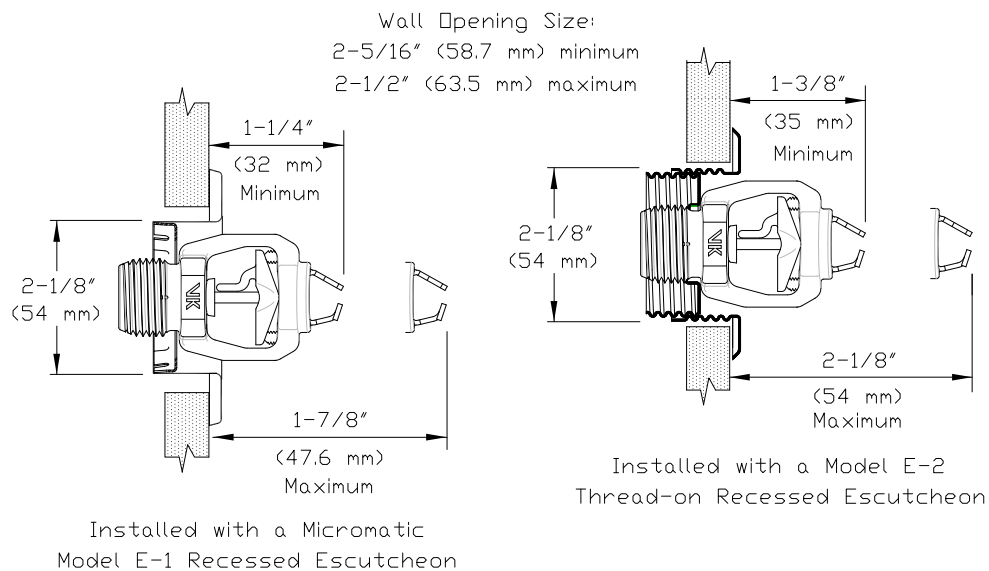

**Figure 5:**  
**Sprinkler VK486 Dimensions with the Model E-1 and E-2 Recessed Escutcheons**



TECHNICAL DATA

FREEDOM® RESIDENTIAL HORIZONTAL SIDEWALL SPRINKLER VK486 (K4.0)

The Viking Corporation, 210 N Industrial Park Drive, Hastings MI 49058  
Telephone: 269-945-9501 Technical Services: 877-384-5464 Fax: 269-818-1680 Email: techsvcs@vikingcorp.com  
Visit the Viking website for the latest edition of this technical data page: www.vikinggroupinc.com

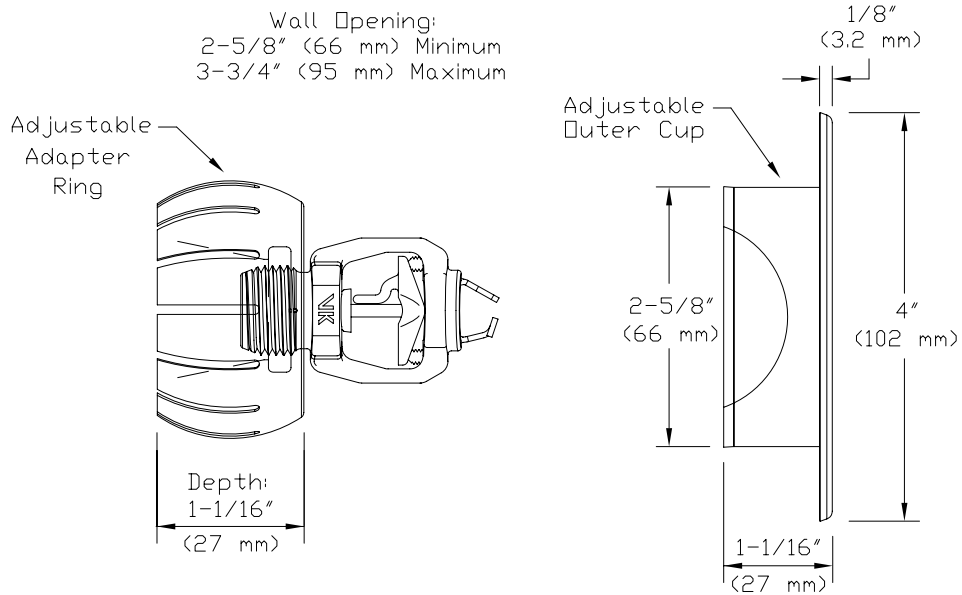

Figure 6: Sprinkler VK486 Dimensions with the Model G-1 Escutcheon



## TECHNICAL DATA

## FREEDOM® RESIDENTIAL CONCEALED PENDENT SPRINKLER VK494 (K4.9)

The Viking Corporation, 210 N Industrial Park Drive, Hastings MI 49058

Telephone: 269-945-9501 Technical Services: 877-384-5464 Fax: 269-818-1680 Email: techsvcs@vikingcorp.com

Visit the Viking website for the latest edition of this technical data page [www.vikinggroupinc.com](http://www.vikinggroupinc.com)

### 1. DESCRIPTION

Viking Freedom® Residential Concealed Pendent Sprinkler VK494 is a small thermosensitive, glass-bulb residential sprinkler designed for installation on concealed pipe systems where the appearance of a smooth ceiling is desired. The orifice design allows the sprinkler's efficient use of available water supplies for the hydraulically designed fire-protection system. The glass bulb operating element and special deflector characteristics meet the challenges of residential sprinkler standards.

#### Features:

- K4.9 (70.6 metric)
- Fast response glass bulb operating element.
- Integral threaded adapter cup accepts push-on or thread-on cover plates.
- Low-profile, small diameter, removeable cover plates offer almost flush appearance upon installation and allow ease of maintenance.
- Protective cap prevents damage during installation and finishing and keeps errant overspray from coating internal parts.
- Various finishes available to meet design requirements.
- Optional Electroless Nickel PTFE (ENT) coating provides corrosion resistance (see Approval Chart).

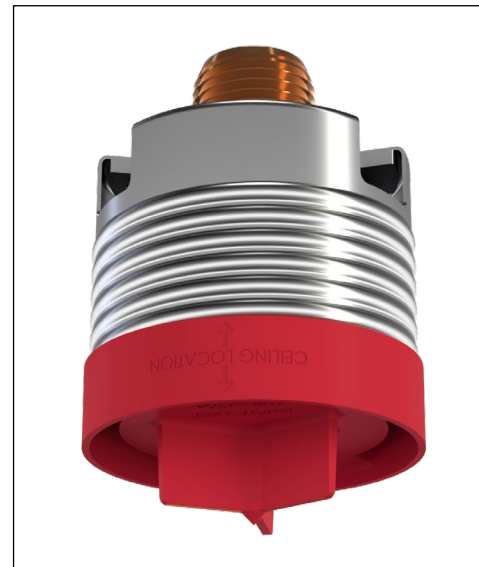

### 2. LISTINGS AND APPROVALS



**cULusEU Listed:** Category VKKW

Refer to the Approval Charts and Design Criteria for C-UL-US-EU Listing requirements that must be followed.



**WARNING:** Cancer and Reproductive Harm-  
[www.P65Warnings.ca.gov](http://www.P65Warnings.ca.gov)

### 3. TECHNICAL DATA

#### Specifications:

Minimum Operating Pressure: Refer to the Approval Chart.

Maximum Working Pressure: 175 psi (12 bar). Factory tested hydrostatically to 500 psi (34.5 bar).

Thread size: 1/2" (15 mm) NPT

Nominal K-factor: 4.9 U.S. (70.6 metric\*)

Glass-bulb fluid temperature rating: to -65 °F (-55 °C)

\* Metric K-factor measurement shown is in Bar. When pressure is measured in kPa, divide the metric K-factor shown by 10.0.

#### Material Standards:

Sprinkler Body: Brass UNS-C84400 or QM Brass

Deflector: Phosphor Bronze UNS-C51000

Deflector Pins: Stainless Steel UNS-S30200

Button: Brass UNS-C36000

Pip Cap and Insert Assembly: Copper UNS-C11000 and Stainless Steel UNS-S30400

Compression Screw: 18-8 Stainless Steel

Yoke: Phosphor Bronze UNS-C51000

Belleville Spring Sealing Assembly: Beryllium Nickel Alloy, coated on both sides with PTFE Tape

Cover Adapter: Cold Rolled Steel JIS G3141 and Carbon Steel UNS-G10100 (per JIS G3141)

Shipping Cap: High Density Polyethylene

Vibration damper ring: Buna-N Rubber SAE AS-568-017

#### Cover Plate Materials:

Cover Plate Assembly: Copper UNS-C11000 and Brass UNS-C26800 or Stainless Steel UNS-S30400

Spring: Beryllium Nickel

Solder: Eutectic

### 4. INSTALLATION

Refer to appropriate NFPA Installation Standards.

### 5. OPERATION

During fire conditions, when the temperature around the sprinkler approaches the cover plate's nominal temperature rating, the cover plate detaches and releases the deflector. Continued heating of the exposed sprinkler causes the heat-sensitive liquid in the glass bulb to expand. When the temperature reaches the sprinkler's nominal temperature rating, the glass bulb shatters releasing the yoke, pip cap assembly and sealing spring. Water begins flowing through the sprinkler orifice and strikes the deflector forming a uniform spray pattern over a specific area of coverage, which is determined by the water supply pressure at the sprinkler, in order to extinguish or control the fire.



## TECHNICAL DATA

## FREEDOM® RESIDENTIAL CONCEALED PENDENT SPRINKLER VK494 (K4.9)

The Viking Corporation, 210 N Industrial Park Drive, Hastings MI 49058  
 Telephone: 269-945-9501 Technical Services: 877-384-5464 Fax: 269-818-1680 Email: techsvcs@vikingcorp.com  
 Visit the Viking website for the latest edition of this technical data page www.vikinggroupinc.com

### 6. INSPECTIONS, TESTS AND MAINTENANCE

Refer to NFPA 25 for Inspection, Testing and Maintenance requirements.

### 7. AVAILABILITY

Viking Sprinkler Model VK494 is available through a network of domestic and international distributors. See The Viking Corporation web site for the closest distributor or contact The Viking Corporation.

### 8. GUARANTEE

For details of warranty, refer to Viking's current list price schedule or contact Viking directly.

**TABLE 1: SPRINKLER ORDERING INFORMATION**

#### Ordering Instructions:

- (1) Select a sprinkler base part number
- (2) Add the suffix for the desired finish
- (3) Add the suffix for the desired sprinkler temperature rating
- (4) Order a cover plate (Must be ordered separately; refer to Table 2)

#### Example:

23707AE = 200 °F (93 °C) Temperature rated sprinkler with a standard brass finish.

Sprinkler Base Part Number <sup>1</sup>	Size	1: Finishes		2: Temperature Ratings <sup>7</sup>			
	NPT Inch	Description	Suffix	Nominal Rating	Bulb Color	Max. Ambient Ceiling Temperature <sup>2</sup>	Suffix
23707	1/2	Brass	A	155 °F (68 °C)	Red	100 °F (38 °C)	B
		ENT <sup>5,6</sup>	JN	200 °F (93 °C)	Green	150 °F (65 °C)	E
		<b>Corrosion resistant sprinkler finish: ENT</b>					

#### Accessories

#### Sprinkler Wrenches and tools (See Figure 1):

- A. Installation wrench: 24339<sup>3</sup>
- B. Protective cap removal tool: 24340<sup>4</sup>
- C. Concealed Cover Plate Installer Tool Part Number: 14412<sup>8</sup> (available since 2007)
- D. Large Concealed Cover Plate Installer Tool Part No. 14867<sup>8</sup> (available since 2007)

#### Sprinkler Cabinet:

Holds up to 6 sprinklers: Part number 01731A (available since 1971).

#### Footnotes

1. Part number shown is the base part number. For complete part number, refer to the current Viking price list schedule.
2. Based on NFPA 13, NFPA 13R, and NFPA 13D. Other limits may apply, depending on fire loading, sprinkler location, and other requirements of the Authority Having Jurisdiction. Refer to specific installation standards.
3. Requires a ½" ratchet (not available from Viking).
4. Optional for removal of the protective cap; requires a small piece of CPVC pipe or similar to attach.
5. cULus Listed as corrosion resistant.
6. The corrosion resistant coatings have passed the standard corrosion test required by the approving agencies indicated in the Approval Charts. These tests cannot and do not represent all possible corrosive environments. Prior to installation, verify through the end-user that the coatings are compatible with or suitable for the proposed environment. For automatic sprinklers, the ENT coating is applied to all exposed exterior surfaces, including the waterway. For ENT coated sprinklers, the Belleville spring is exposed.
7. The sprinkler temperature rating is stamped on the deflector.
8. The installer tool is for push-on style cover plates only.
9. Requires a peice of 1" PVC pipe or similar to attach.



## TECHNICAL DATA

## FREEDOM® RESIDENTIAL CONCEALED PENDENT SPRINKLER VK494 (K4.9)

The Viking Corporation, 210 N Industrial Park Drive, Hastings MI 49058  
 Telephone: 269-945-9501 Technical Services: 877-384-5464 Fax: 269-818-1680 Email: techsvcs@vikingcorp.com  
 Visit the Viking website for the latest edition of this technical data page www.vikinggroupinc.com

### TABLE 2: COVER PLATE ORDERING INFORMATION

#### Instructions:

- (1) Select a cover plate base part number
- (2) Add the suffix for the desired finish
- (3) Add the suffix for the required cover plate nominal rating.

#### Example:

23190MC/W = 165 °F (74 °C) Temperature rated, 2-3/4" (70 mm) diameter, thread-on style, round cover plate with a painted white finish.

1: Select a Cover Plate Base Part Number <sup>3</sup>						2: Select a Finish	
Thread-On Style			Push-On Style			Description	Suffix <sup>5</sup>
Base Part Number <sup>1</sup>	Size Inch (mm)	Type	Base Part Number	Size Inch (mm)	Type		
23190	2-3/4 (70)	Round	23447	2-3/4 (70)	Round	Polished Chrome	F
23174	3-5/16 (84)	Round	23463	3-5/16 (84)	Round	Brushed Chrome	F-/B
23179	3-5/16 (84)	Square	23482	3-5/16 (84)	Square	Bright Brass	B
23193 <sup>5</sup>	2-3/4 (70)	Stainless Steel Round	23455 <sup>5</sup>	2-3/4 (70)	Stainless Steel Round	Antique Brass	B-/A
						Brushed Brass	B-/B
23183 <sup>5</sup>	3-5/16 (84)	Stainless Steel Round	23473 <sup>5</sup>	3-5/16 (84)	Stainless Steel Round	Brushed Copper	E-/B
						Painted White	M-/W
						Painted Ivory	M-/I
						Painted Black	M-/B

3: Temperature Rating Matrix <sup>1,2</sup>				
Cover Plate Nominal Rating (Required)	Temperature Classification	Sprinkler Nominal Rating	Sprinkler Maximum Ambient Ceiling Temperature <sup>2</sup>	Suffix
135 °F (57 °C)	Ordinary	155 °F (68 °C)	100 °F (38 °C)	<b>A</b>
165 °F (74 °C)	Intermediate	200 °F (93 °C)	150 °F (65 °C)	<b>C</b>

#### Footnotes

1. Part number shown is the base part number. For complete part number, refer to the current Viking price list schedule.
2. The sprinkler temperature rating is stamped on the deflector.
3. Based on NFPA-13, NFPA 13R, and NFPA 13D. Other limits may apply, depending on fire loading, sprinkler location, and other requirements of the Authority Having Jurisdiction. Refer to specific installation standards.
4. Where a dash (-) is shown in the Finish suffix designation, insert the desired Temperature Rating suffix. See example above.
5. Stainless Steel versions are not available with any finishes or paint.





TECHNICAL DATA

FREEDOM® RESIDENTIAL  
CONCEALED PENDENT  
SPRINKLER VK494 (K4.9)

The Viking Corporation, 210 N Industrial Park Drive, Hastings MI 49058  
Telephone: 269-945-9501 Technical Services: 877-384-5464 Fax: 269-818-1680 Email: techsvcs@vikingcorp.com  
Visit the Viking website for the latest edition of this technical data page [www.vikinggroupinc.com](http://www.vikinggroupinc.com)



Installation Wrench



Cap Removal Tool

Figure 1: Sprinkler Wrench and Cap Removal Tool

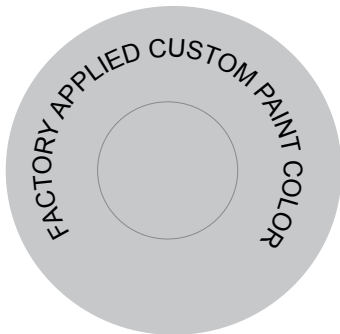

All custom color painted cover plates will have an identifying label affixed to the inside of the cover that indicates the custom color and will have a representative sample (a paint dot) of the paint on the label.

Figure 2: Identification of Custom Paint

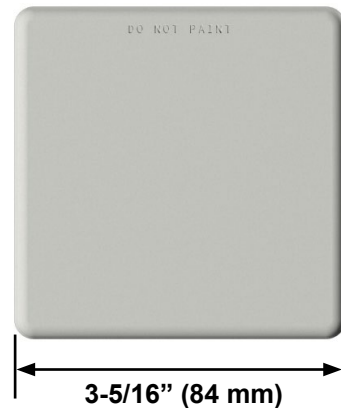

Figure 3: Square Cover Assembly



**TECHNICAL DATA**

**FREEDOM® RESIDENTIAL  
CONCEALED PENDENT  
SPRINKLER VK494 (K4.9)**

The Viking Corporation, 210 N Industrial Park Drive, Hastings MI 49058  
 Telephone: 269-945-9501 Technical Services: 877-384-5464 Fax: 269-818-1680 Email: techsvcs@vikingcorp.com  
 Visit the Viking website for the latest edition of this technical data page www.vikinggroupinc.com

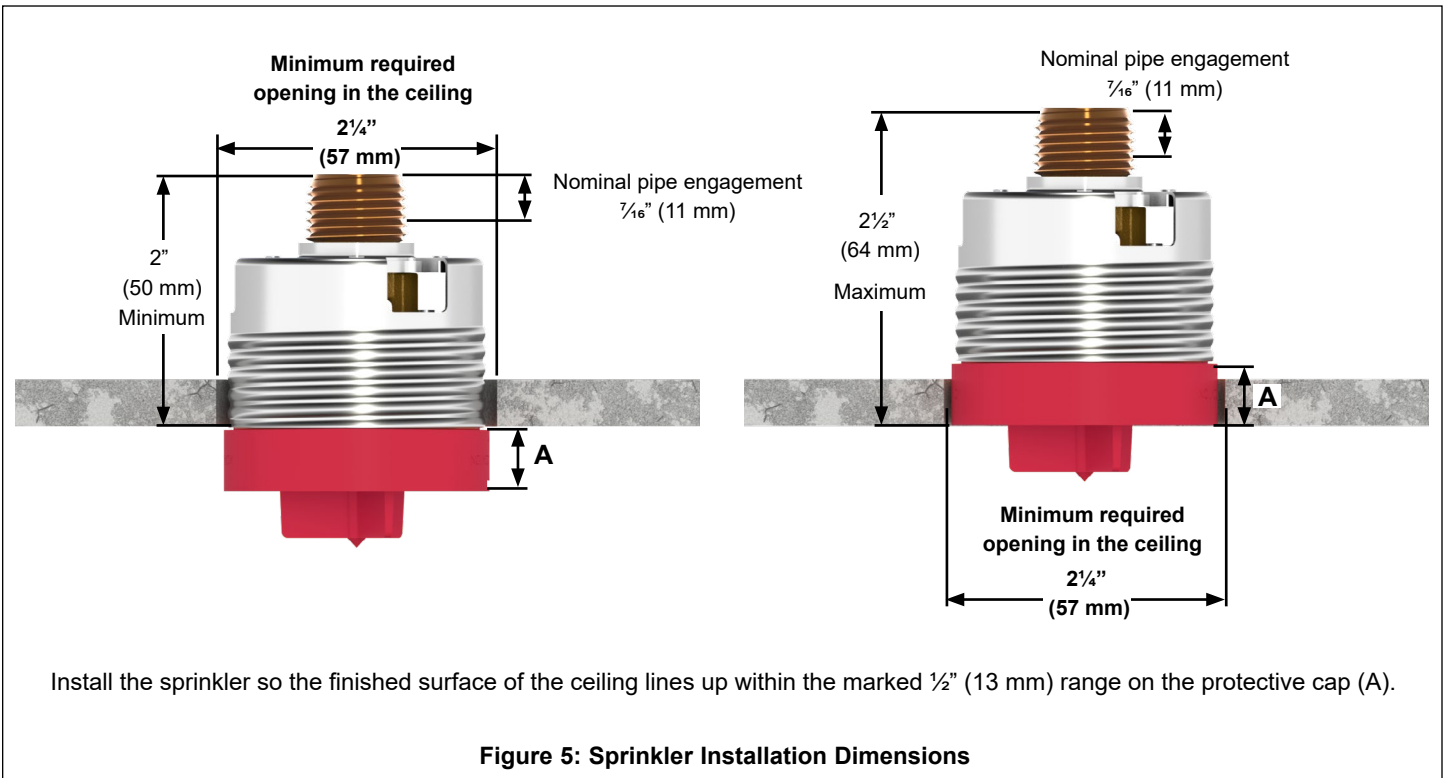
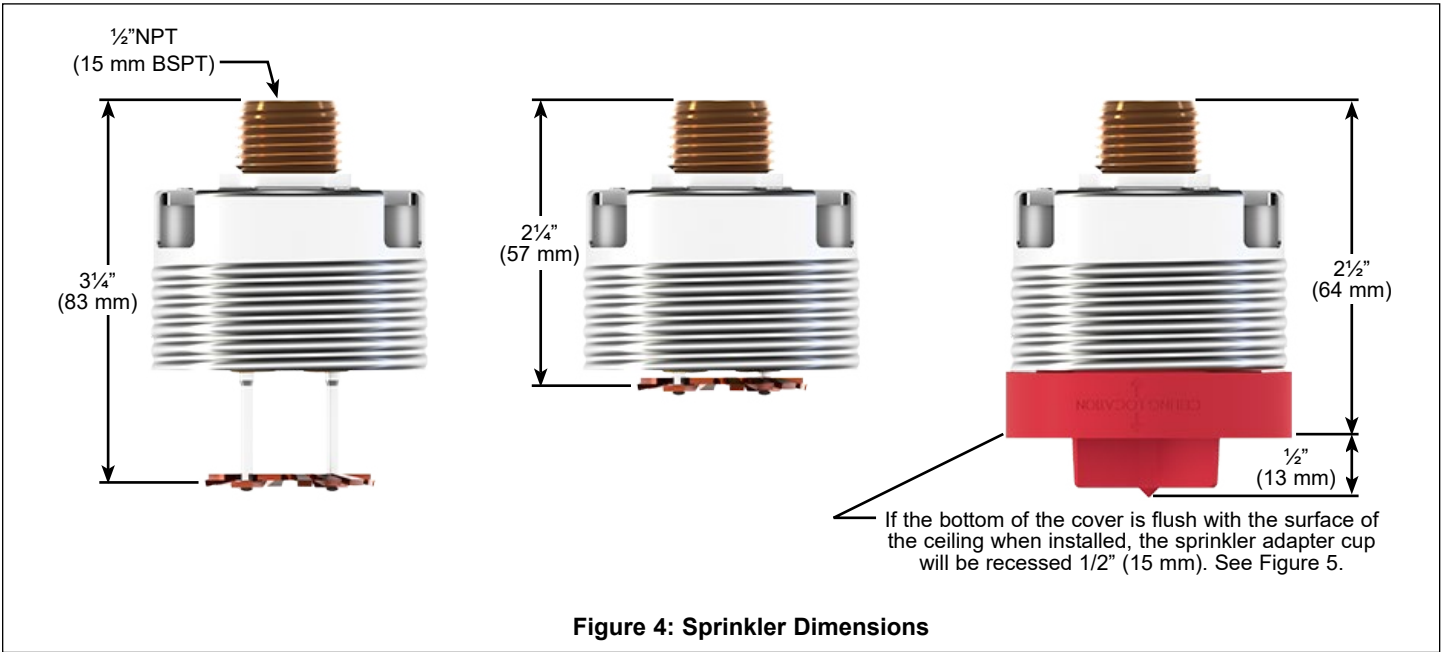



## TECHNICAL DATA

## FREEDOM® RESIDENTIAL CONCEALED PENDENT SPRINKLER VK494 (K4.9)

The Viking Corporation, 210 N Industrial Park Drive, Hastings MI 49058  
 Telephone: 269-945-9501 Technical Services: 877-384-5464 Fax: 269-818-1680 Email: techsvcs@vikingcorp.com  
 Visit the Viking website for the latest edition of this technical data page www.vikinggroupinc.com

### Approval Chart Viking VK494, 4.9 K-factor Residential Concealed Pendent Sprinkler

For systems designed to NFPA 13D or NFPA 13R. For systems designed to NFPA 13, refer to the Design Criteria. For Ceiling types refer to current editions of NFPA 13, 13R or 13D

Sprinkler Base Part Number <sup>1</sup>	SIN	Thread Size			Nominal K-factor		Maximum Water Working Pressure
		NPT	BSPT		U.S.	metric <sup>2</sup>	
20759	VK494	1/2"	15 mm		4.9	70.6	175 psi (12 bar)
Max. Coverage Area <sup>6</sup> W X L Ft. X Ft. (m X m)	Flow GPM (LPM)		Pressure PSI (bar)	Deflector to Ceiling	Installation Type	Listings and Approvals <sup>3,5</sup>	Minimum Spacing Ft. (m)
	155 °F (68 °C), 200 °F (93 °C) Temperature Rated Sprinklers					cULusEU <sup>4</sup>	
12 X 12 (3.7 X 3.7)	13 (49.2)	7.0 (0.48)	Refer to Figure 2	Concealed with Cover Plate Assembly. See Footnote 7.	See Footnotes 8, & 9	8 (2.4)	
14 X 14 (4.3 X 4.3)	13 (49.2)	7.0 (0.48)					
16 X 16 (4.9 X 4.9)	13 (49.2)	7.0 (0.48)					
18 X 18 (5.5 X 5.5)	17 (64.4)	12.0 (0.83)					
20 X 20 (6.1 X 6.1)	20 (75.7)	16.7 (1.15)					

#### Footnotes

- Part number shown is the base part number. For complete part number, refer to the current Viking price schedule.
- Metric K-factor measurement shown is when pressure is measured in Bar. When pressure is measured in kPa, divide the metric K-factor shown by 10.0.
- This chart shows the listings and approvals available at the time of printing. Other approvals may be in process. Check with the manufacturer for any additional approvals. Refer also to Design Criteria.
- Listed by Underwriter's Laboratories, Inc. for use in the U.S., Canada, and European Union.
- Meets New York City requirements, effective July 1, 2008.
- For areas of coverage smaller than shown, use the "Flow" and "Pressure" for the next larger area listed. Flows and pressures listed are per sprinkler. The distance from sprinklers to walls shall not exceed one-half the sprinkler spacing indicated for the minimum "Flow" and "Pressure" used.
- Other paint colors are available on request with the same listings as the standard finish colors. Stainless Steel cover plates are not available with any finishes or paint. Listings and approvals apply for any paint manufacturer. Contact Viking for additional information. Custom colors are indicated on a label inside the cover assembly. Refer to Figure 2.
- Accepted Cover Plate Finishes are: Polished Chrome, Brushed Chrome, Bright Brass, Antique Brass, Brushed Brass, Brushed Copper, Painted White, Painted Ivory, or Painted Black <sup>7</sup>.
- C-UL-US-EU Listed as corrosion resistant - Electroless Nickel PTFE (ENT)

### DESIGN CRITERIA

(Also refer to the Approval Chart.)

#### UL Listing Requirements (C-UL-US-EU):

When using Viking Residential Concealed Pendent Sprinkler VK494 for systems designed to NFPA 13D or NFPA 13R, apply the listed areas of coverage and minimum water supply requirements shown in the Approval Chart.

**For systems designed to NFPA 13:** The number of design sprinklers is to be the four contiguous most hydraulically demanding sprinklers. The minimum required discharge from each of the four sprinklers is to be the greater of the following:

- The flow rates given in the Approval Chart for NFPA 13D and NFPA 13R applications for each listed area of coverage, **or**
- Calculated based on a minimum discharge of 0.1 gpm/sq. ft. over the "design area" in accordance with sections 9.5.2.1 or 10.2.4.1.2 of the current edition of NFPA 13.
- Minimum distance between residential sprinklers: 8 ft. (2.4 m).

**NOTE: Concealed sprinklers must be installed in neutral or negative pressure plenums only.**

**IMPORTANT: Always refer to Bulletin Form No. F\_080415 - Best Practices for Residential Sprinkler Handling and Installation. Also refer to Form No. F\_080614 for general care, installation, and maintenance information. Viking sprinklers are to be installed in accordance with the latest edition of Viking technical data, the appropriate standards of NFPA and any other similar Authorities Having Jurisdiction, and also with the provisions of governmental codes, ordinances, and standards, whenever applicable. Final approval and acceptance of all residential sprinkler installations must be obtained from the Authorities Having Jurisdiction.**



TECHNICAL DATA

FREEDOM® RESIDENTIAL CONCEALED PENDENT SPRINKLER VK494 (K4.9)

The Viking Corporation, 210 N Industrial Park Drive, Hastings MI 49058  
 Telephone: 269-945-9501 Technical Services: 877-384-5464 Fax: 269-818-1680 Email: techsvcs@vikingcorp.com  
 Visit the Viking website for the latest edition of this technical data page www.vikinggroupinc.com



USE ONLY the designated sprinkler wrenches shown in this document. Permanent damage to the sprinkler assembly can occur if the proper wrench is not used. Other sprinkler wrenches available from Viking may fit into the sprinkler adapter cup; however, only the wrenches shown here are designed to properly install this sprinkler.

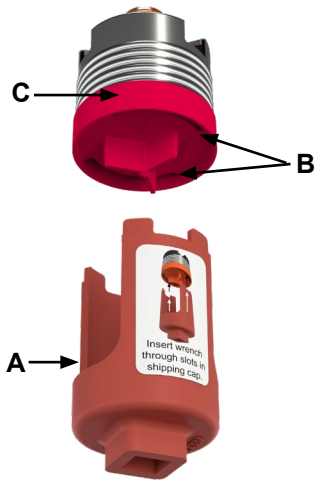

Step 1:  
 Insert the wrench (A) into the slots (B) on the protective cap (C).

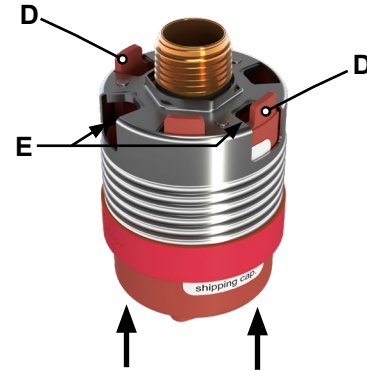

Step 2:  
 Rotate the wrench slightly in either direction until the tines on the wrench (D) line up with the vent openings (E) on the adapter cup and lock into place. NOTE: A leak tight seal must be achieved. Turn the sprinkler clockwise 1 to 1-½ turns past finger-tight.

Figure 6: Using the Sprinkler Wrench

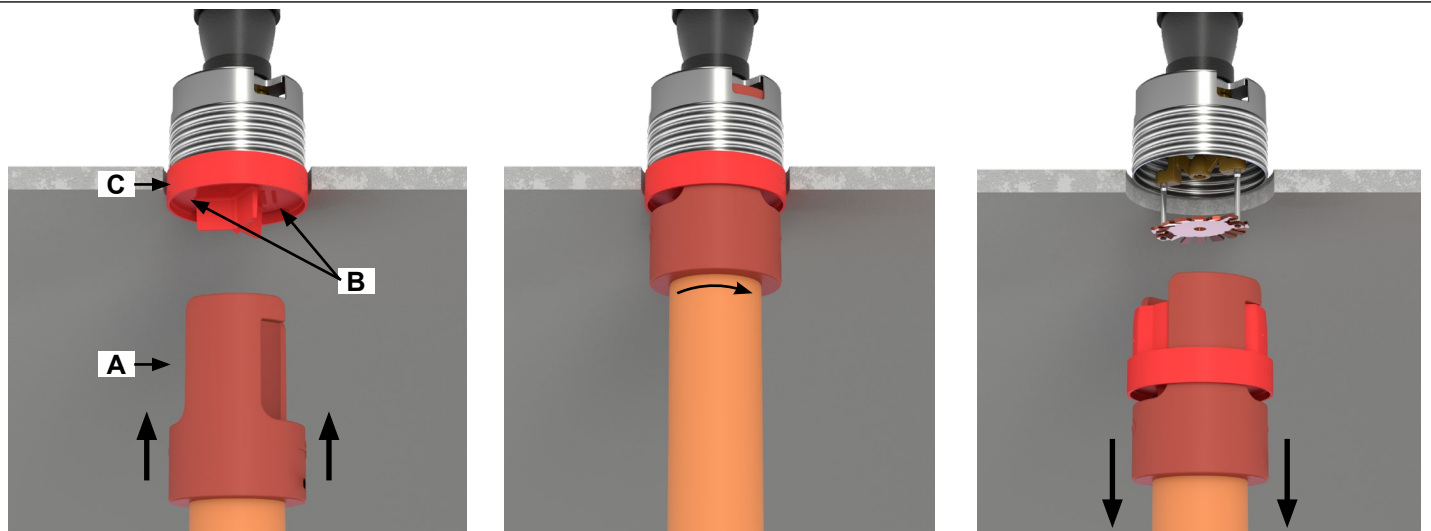

Step 1:  
 Attach a peice of plastic pipe as shown and tighten the thumb screw (not shown); then, insert the tool (A) into the slots (B) in the protective cap (C).

Step 2:  
 Rotate the tool slightly to lock into place.

Step 2:  
 Gently, pull downward to remove the protective cap. The deflector will slide downwards on the pins.

Figure 7: Using the Cap Removal Tool



## TECHNICAL DATA

## FREEDOM® RESIDENTIAL CONCEALED PENDENT SPRINKLER VK494 (K4.9)

The Viking Corporation, 210 N Industrial Park Drive, Hastings MI 49058  
 Telephone: 269-945-9501 Technical Services: 877-384-5464 Fax: 269-818-1680 Email: techsvcs@vikingcorp.com  
 Visit the Viking website for the latest edition of this technical data page [www.vikinggroupinc.com](http://www.vikinggroupinc.com)

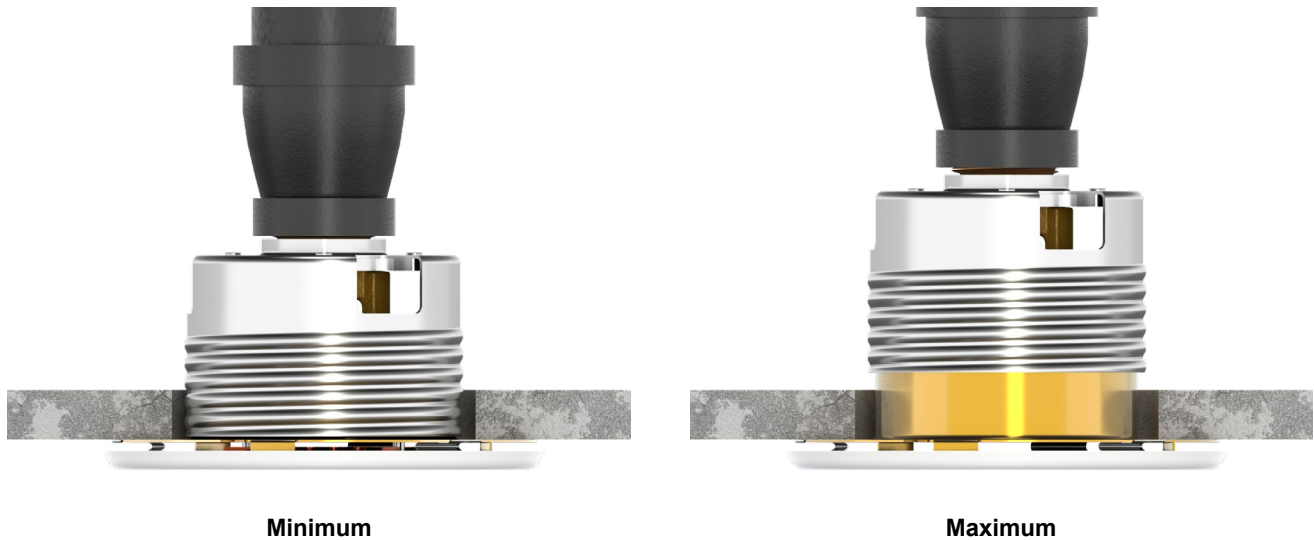

Install the cover plate by inserting the adapter into the adapter cup and pushing or threading into place (depending on style). Snug the cover plate in place by rotating clockwise. Ensure the cover plate is flush with the ceiling as shown to allow airflow through the sprinkler assembly.

Figure 8: Installing the Cover Plate



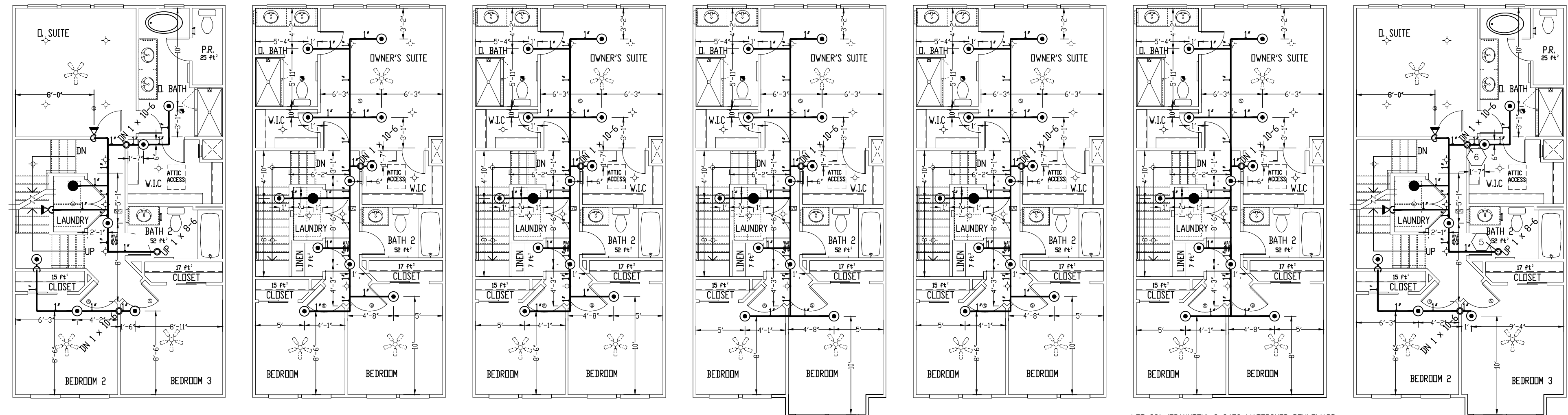

LOT 226 (HALSTON LOFT) @ 3463 WATERSHED BOULEVARD  
 LOT 227 (FRANKTON) @ 3461 WATERSHED BOULEVARD  
 LOT 228 (FRANKTON) @ 3459 WATERSHED BOULEVARD  
 LOT 229 (FRANKTON) @ 3457 WATERSHED BOULEVARD  
 LOT 230 (FRANKTON) @ 3455 WATERSHED BOULEVARD  
 LOT 231 (FRANKTON) @ 3453 WATERSHED BOULEVARD  
 LOT 232 (HALSTON W/ LOFT) @ 3451 WATERSHED BOULEVARD

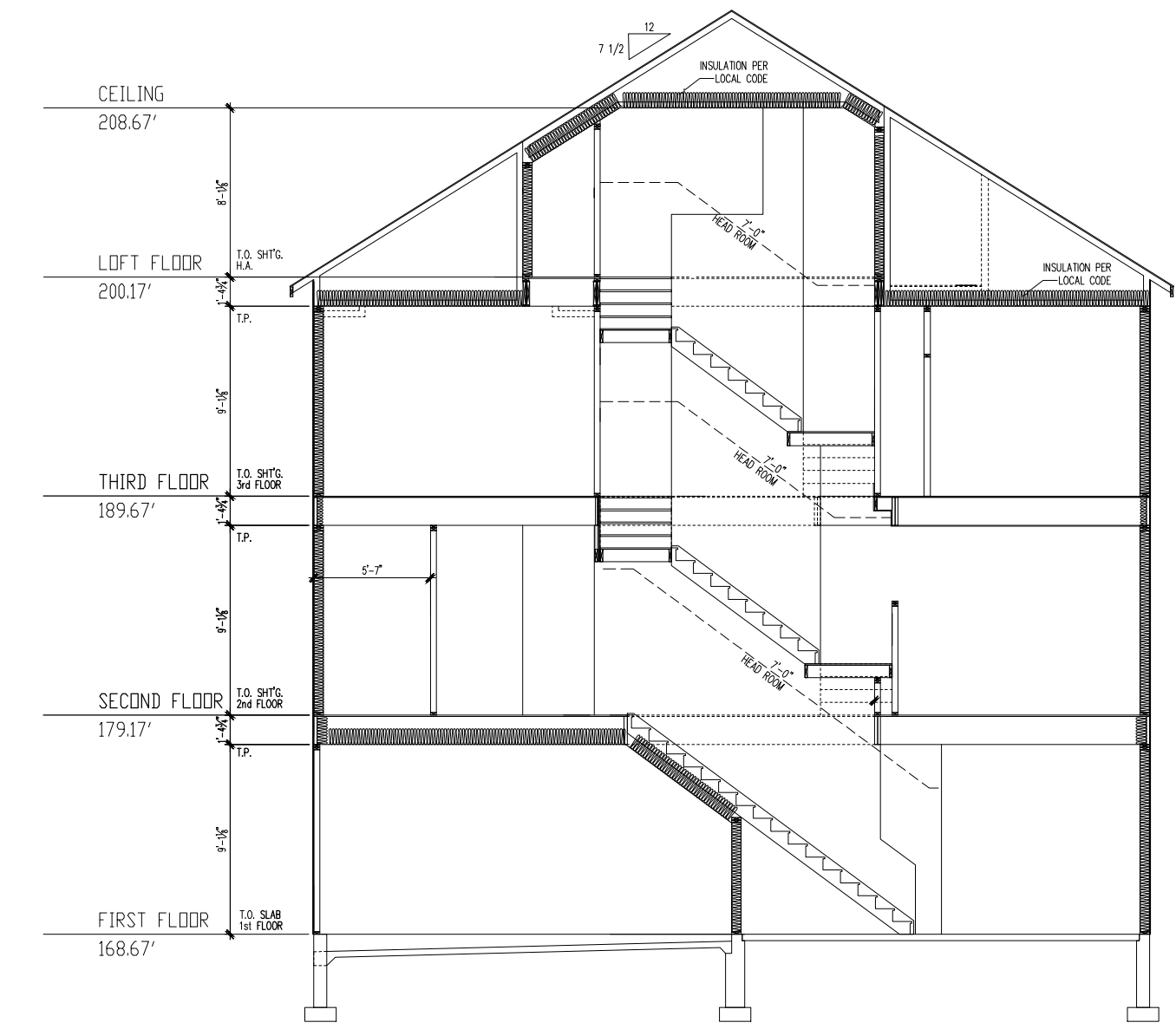

SECTION A-A  
 SCALE: N.T.S.

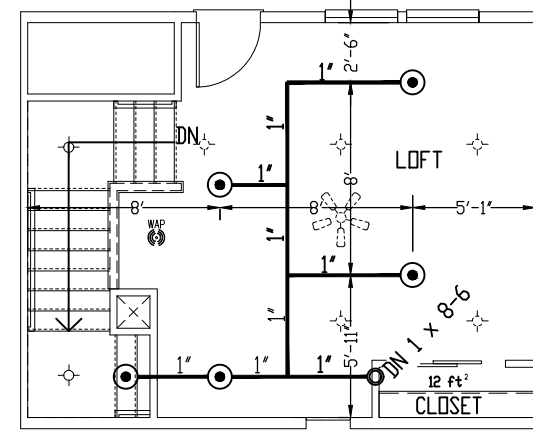

LOT 226 (HALSTON W/ LOFT) @ 3463 WATERSHED BOULEVARD

THIRD FLOOR PLAN  
 SCALE: 1/8"=1'-0"

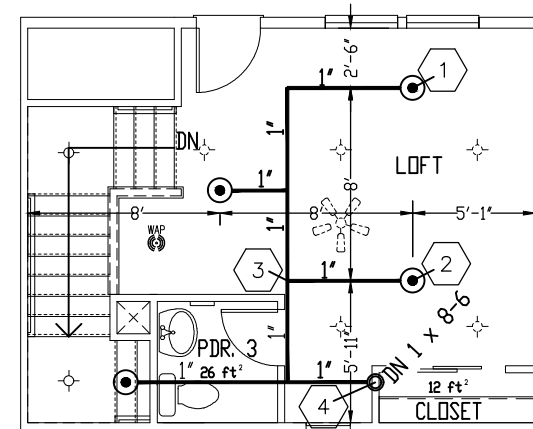

LOT 232 (HALSTON W/ LOFT) @ 3451 WATERSHED BOULEVARD

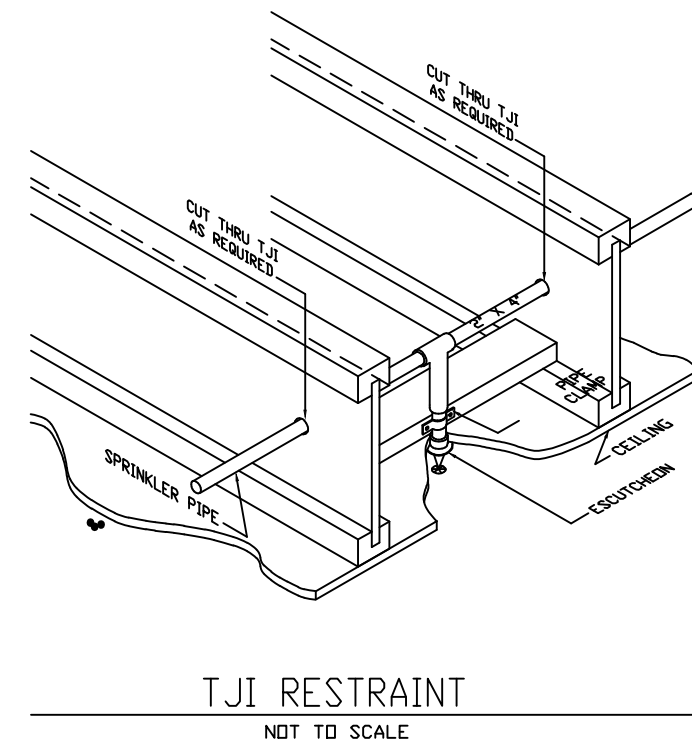

TJI RESTRAINT  
 NOT TO SCALE

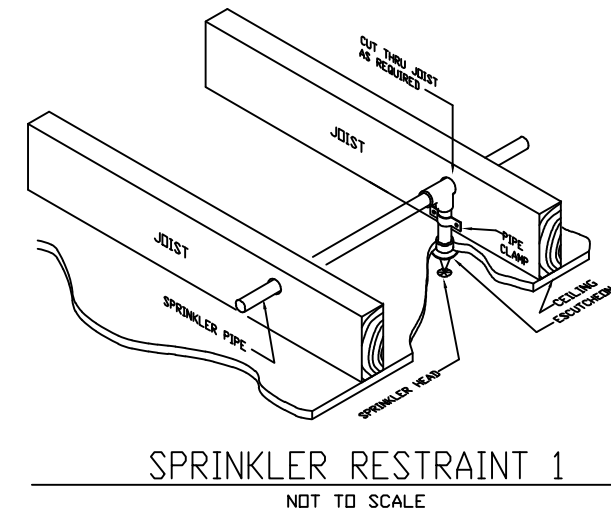

SPRINKLER RESTRAINT 1  
 NOT TO SCALE

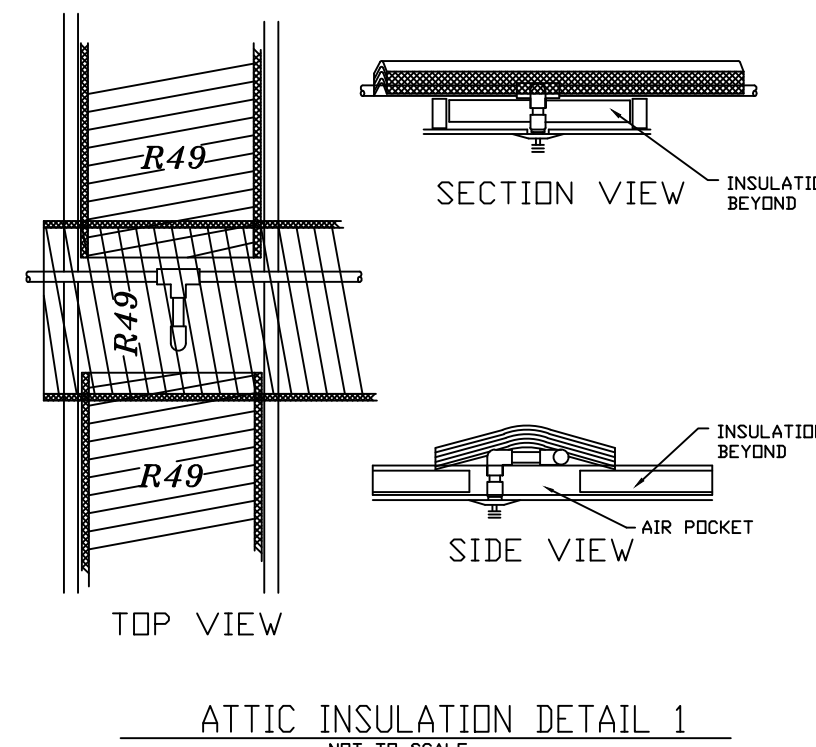

ATTIC INSULATION DETAIL 1  
 NOT TO SCALE

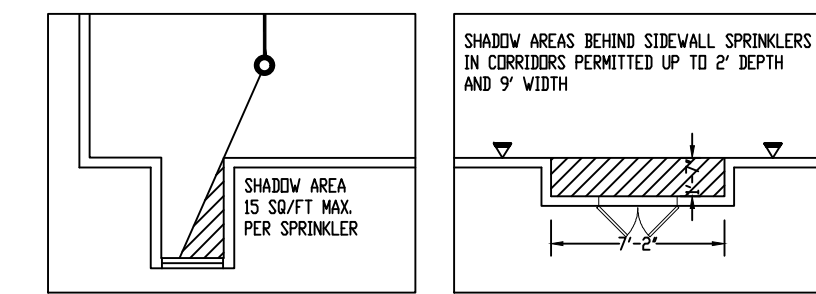

SHADOW AREA DETAIL

LOFT FLOOR PLAN  
 SCALE: 1/8"=1'-0"

1 PENDENT  
 FILE .sdf : 1 PENDENT  
 HAZARD : NFPA-13D  
 DESIGN AREA : LOFT FLR. REMOTE  
 AREA PER HEAD : 20 X 20  
 # OF HEADS : 1  
 DEMAND : 25.0 GPM @ 61.8 PSI @ SRC  
 SAFETY : 26.2 PSI --- 29.77%

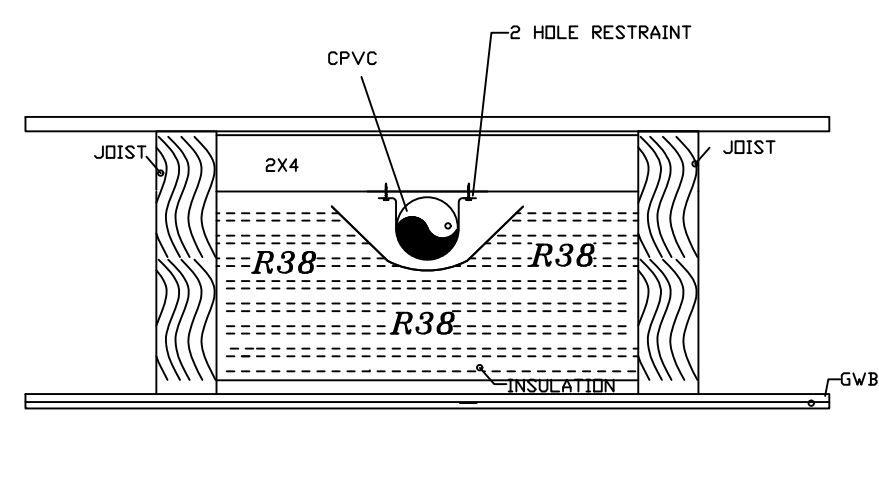

GARAGE INSULATION DETAIL  
 NOT TO SCALE

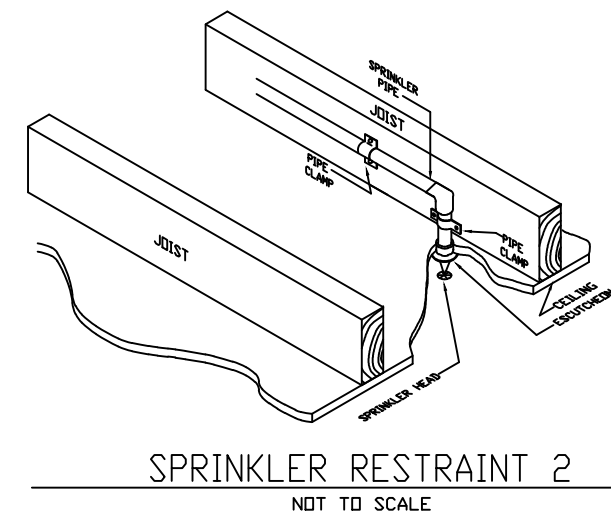

SPRINKLER RESTRAINT 2  
 NOT TO SCALE

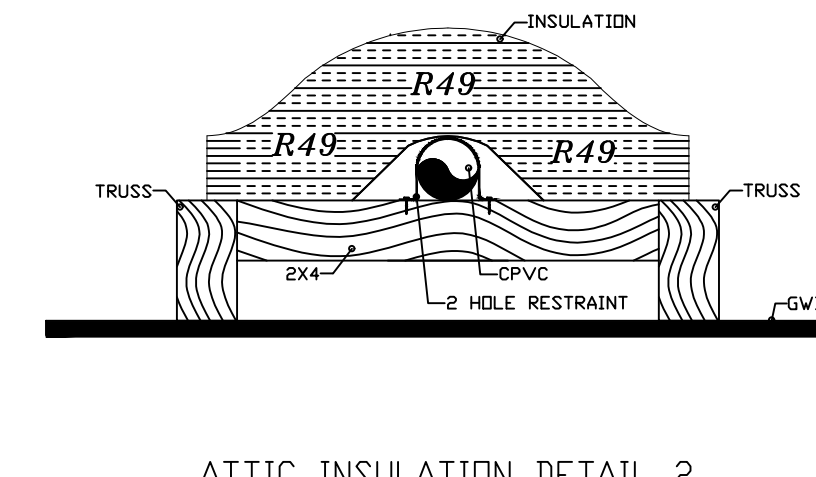

ATTIC INSULATION DETAIL 2  
 NOT TO SCALE

2 PENDENT  
 FILE .sdf : 2 PENDENT  
 HAZARD : NFPA-13D  
 DESIGN AREA : LOFT FLR. REMOTE  
 AREA PER HEAD : 16 X 16  
 # OF HEADS : 2  
 DEMAND : 31.3 GPM @ 64.2 PSI @ SRC  
 SAFETY : 23.8 PSI --- 27.04%

Lot	Model	Permit	Address
226	Halston Loft	B-02400573	3463 Watershed Boulevard
227	Frankton	B-02400574	3461
228	Frankton	B-02400575	3459
229	Frankton	B-02400576	3457
230	Frankton	B-02400577	3455
231	Frankton	B-02400578	3453
232	Halston Loft	B-02400579	3451

SPRINKLER SPACING

Type	No. Head/Rm.	Spacing	Slope
Pendent	2+	16x16	8/12
Pendent	1	20x20	8/12
Sidewall	2+	16x16	8/12

NOEL'S FIRE PROTECTION

12015 KEMPS MILL ROAD  
 WILLIAMSPORT, MD 21795  
 (240) 366-8287 FAX: (301) 223-8370

CONTRACTOR: PULTE GROUP MID-ATLANTIC MARKET  
 9302 LEE HIGHWAY, SUITE 1000  
 FAIRFAX, VA 22031

PERMIT # See Address Block Model: TOWNS / Job# 343-N SHEET No. 2

DATE 12-1-2021 WATERSHED TOWNS, LOTS 226-232 2

DESIGNER Scott Mullendore 3463-3451 WATERSHED BOULEVARD OF

SCALE 1/8" = 1'-0" LAUREL, MD 20724 2

TOTAL SPRINKLERS THIS DRAWING 88

DESIGN CRITERIA

TYPE SYSTEM:  WET  DRY NFPA STANDARD:  #13  #13R  #130  
 OCCUPANCY: Single Family Towns  
 HAZARD: Light  
 DENSITY: .05 GPM/S.F.  
 REMOTE AREA: LOFT FLR.F.  
 MAX. S.F./HD. See Note  
 HOSE REQ'NT.:  100  250  500  
 APPROVING AUTHORITY: ANNE ARUNDEL COUNTY

PIPE SCHEDULE

1'  
 1 1/2"  
 2"  
 INCOMING FROM STREET

PIPE SYMBOLS

⊙ RISER/MANIFOLD  
 ⊙ ELBOW DOWN  
 ⊙ BALL VALVE  
 ⚠ REVISION

SPRINKLER SUMMARY

SYM	TYPE	FINISH	TEMP	ORIF.	"K"	NPT	Mfg.	MODEL#	ESCUTCHEON	QTY.	BY	DATE	#
●	RES. PEND	WHITE	155°	1/2"	4.9	1/2"	VICTALIC	V2740	RECESSED	77			△
●	RES. PEND	WHITE	175°	1/2"	4.9	1/2"	VICTALIC	V2740	RECESSED	07			△
◄	SIDEWALL	WHITE	155°	1/2"	4.0	1/2"	VIKING	VK486	RECESSED	04			△

REVISIONS

DATE	DESCRIPTION	#
		△
		△
		△
		△
		△
		△

FOREMAN NOTES:  
 1. CHANGES TO THIS PRINT MUST BE FOLLOWED UP WITH ASBULTS AS THEY ARE MADE AND TAKEN TO THE OFFICE.

IMPORTANT  
 THIS DRAWING, THE INFORMATION, AND DESIGN APPLICATION CONTAINED HEREIN IS THE PROPERTY OF NOEL'S FIRE PROTECTION AND/OR ITS SUBSIDIARIES. ALL INFORMATION HEREIN CONTAINED SHALL BE TREATED AS CONFIDENTIAL. NO REPRODUCTION OF THIS DRAWING OR ANY PART THEREOF SHALL BE MADE WITHOUT WRITTEN CONSENT OF NOEL'S FIRE PROTECTION.

# Victaulic® FireLock™ Series FL-RES

## Residential, Quick Response

### Pendent and Recessed Pendent, K3.0 (4.3), K4.9 (7.0), K5.6 (8.0), K6.9 (9.9)



## 1.0 PRODUCT DESCRIPTION

RESIDENTIAL PENDENT/RECESSED PENDENT SPRINKLERS				
SIN	V3010	V2740	V5610	V3426
ORIENTATION	PENDENT	PENDENT	PENDENT	PENDENT
K-FACTOR <sup>1</sup>	3.0 Imp./4.2 S.I.	4.9 Imp./7.1 S.I.	5.6 Imp./8.1 S.I.	6.9 Imp./9.9 S.I.
CONNECTION	½" NPT/15 mm	½" NPT/15 mm	½" NPT/15 mm	¾" NPT/20 mm
MAX. WORKING PRESSURE	175 psi (1200 kPa)	175 psi (1200 kPa)	175 psi (1200 kPa)	175 psi (1200 kPa)
GLOBE RE-DESIGNATION	GL3010	–	GL5610	–
GLOBE EQUIVALENT	–	GL4910	–	–

AVAILABLE WRENCHES						
SPRINKLER	V27 Recessed	V27 Open End	V56 Recessed	V56 Open End	V34 Recessed	V34 Open End
V3010			■	■		
V2740	■	■				
V5610			■	■		
V3426					■	■

**Factory Hydrostatic Test:** 100% @ 500 psi/3447 kPa/34 bar

**Min. Operating Pressure: UL:** 7psi/48 kPa/5 bar

**Temperature Rating:** See tables in section 2.0

<sup>1</sup> For K-Factor when pressure is measured in bar, multiply S.I. units by 10.0.

ALWAYS REFER TO ANY NOTIFICATIONS AT THE END OF THIS DOCUMENT REGARDING PRODUCT INSTALLATION, MAINTENANCE OR SUPPORT.



2.0 CERTIFICATION/LISTINGS

SIN	Nominal K Factor		Listing Agency/ Approved Temperature Ratings			Max. Coverage Area Width X Length Ft. x Ft m x m	Flow GPM L/min	Pressure PSI kPa	Adjustment in mm	Deflector to Ceiling/ Mounting Surface Distance in (mm)	Minimum Spacing Ft. m
	Imperial	S.I. <sup>2</sup>	155°F/68°C	175°F/79°C	200°F/93°C						
V3010	3.0	4.2	cULus EU	cULus	cULus	12 x 12	8	7.1	½ 15		
						3.7 x 3.7	30.3	49			
V2740	4.9	7.1	cULus	cULus	N/A	14 x 14	10	11.1	½ and ¾ 15 and 20	Smooth Ceilings Recessed See Installation Detail	
						4.3 x 4.3	37.8	76.5			
						12 x 12	13	7.0			
						3.7 x 3.7	49.2	48			
						14 x 14	13	7.0			
						4.3 x 4.3	49.2	48			
V5610	5.6	8.1	cULus	NA	N/A	16 x 16	13	7.0	½ 15	Smooth Ceilings Exposed Max. 4 (101.6)	
						4.9 x 4.9	49.2	48			
						18 x 18	17	12.0			
						5.5 x 5.5	64.3	83			
						20 x 20	20	16.7			
						6.1 x 6.1	75.7	115			
V3426	6.9	9.9	cULus	cULus	N/A	12 x 12	15	7.2	½ 15	Beamed Ceilings Adjacent per NFPA 13, 13D, or 13R as appropriate	8 2.4
						3.7 x 3.7	57	50			
						16 x 16	19	11.5			
						4.9 x 4.9	72	79			
V3426	6.9	9.9	cULus	cULus	N/A	18 x 18	21	14.1	½ and ¾ 15 and 20	Beamed Ceilings In Beam 14 Max. Beam Depth Recessed in Beam: See Installation detail	
						5.5 x 5.5	79	97			
						20 x 20	24	18.4			
						6.1 x 6.1	91	127			
						12 x 12	20	8.4			
						3.7 x 3.7	75.7	58			

NOTE

- Listings and approval as of printing.

### 3.0 SPECIFICATIONS – MATERIAL

**Deflector:** Bronze

**Bulb Nominal Diameter:** 3.0mm

**Load Screw:** Bronze

**Pip Cap:** Bronze

**Spring Seal Assembly:** PTFE coated Beryllium nickel alloy

**Frame:** Brass

**Lodgement Spring:** Stainless Steel

**Installation Wrench:** Ductile iron

**Sprinkler Frame Finishes:**

- Plain brass
- Chrome plated
- White polyester painted
- Flat black polyester painted
- Custom polyester painted

**NOTE**

- For cabinets and other accessories refer to separate sheet.

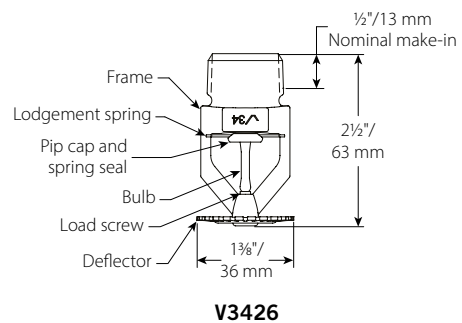
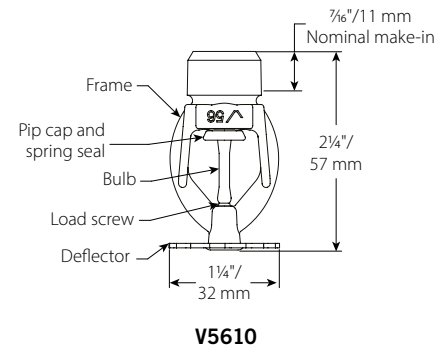
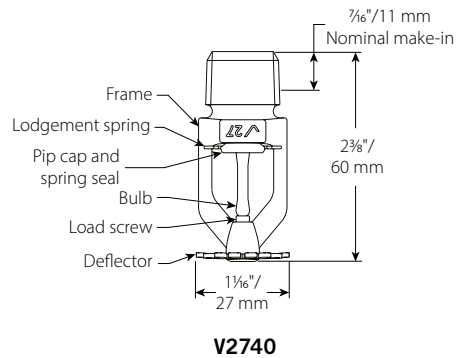
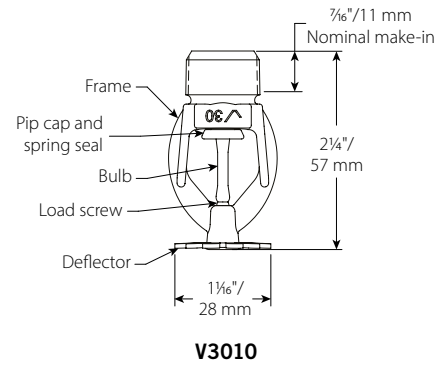

## 4.0 DIMENSIONS

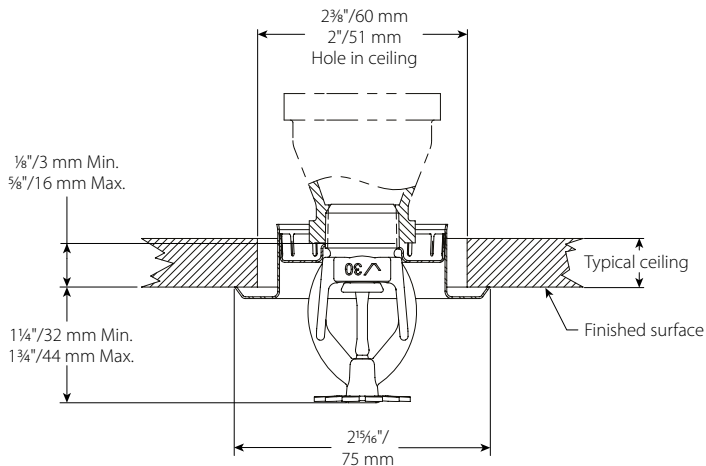

**V3010**

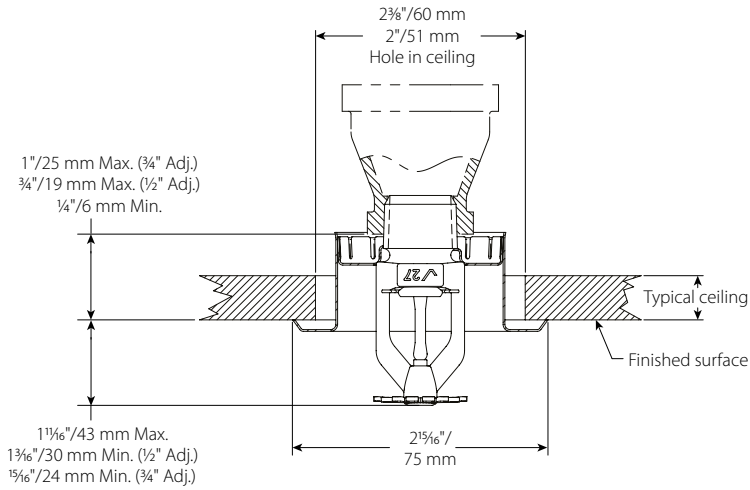

**V2740**

### 4.0 DIMENSIONS (CONTINUED)

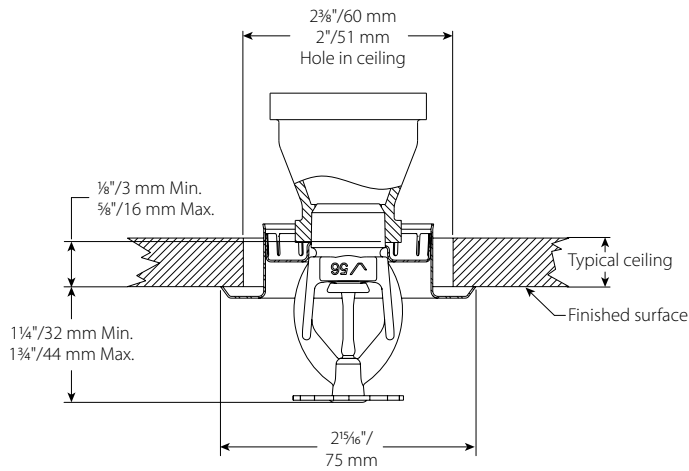

**V5610**

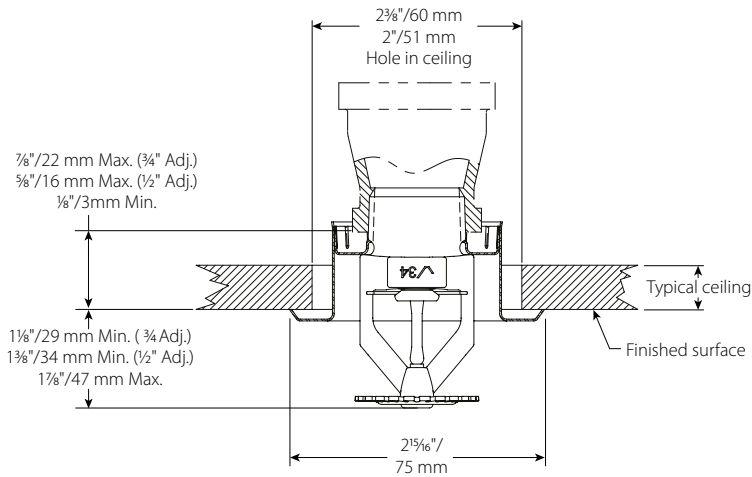







**V3426**

## 5.0 PERFORMANCE

Sprinkler is to be installed and designed as per NFPA, FM Datasheets, or any local standards.

## 6.0 NOTIFICATIONS

 <b>WARNING</b>	
    	<ul style="list-style-type: none"><li>• Read and understand all instructions before attempting to install any Victaulic products.</li><li>• Always verify that the piping system has been completely depressurized and drained immediately prior to installation, removal, adjustment, or maintenance of any Victaulic products.</li><li>• Wear safety glasses, hardhat, and foot protection.</li></ul> <p>Failure to follow these instructions could result in death or serious personal injury and property damage.</p>
<ul style="list-style-type: none"><li>• These products shall be used only in fire protection systems that are designed and installed in accordance with current, applicable National Fire Protection Association (NFPA 13, 13D, 13R, etc.) standards, or equivalent standards, and in accordance with applicable building and fire codes. These standards and codes contain important information regarding protection of systems from freezing temperatures, corrosion, mechanical damage, etc.</li><li>• The installer shall understand the use of this product and why it was specified for the particular application.</li><li>• The installer shall understand common industry safety standards and potential consequences of improper product installation.</li><li>• It is the system designer's responsibility to verify suitability of materials for use with the intended fluid media within the piping system and external environment.</li><li>• The material specifier shall evaluate the effect of chemical composition, pH level, operating temperature, chloride level, oxygen level, and flow rate on materials to confirm system life will be acceptable for the intended service.</li></ul> <p>Failure to follow installation requirements and local and national codes and standards could compromise system integrity or cause system failure, resulting in death or serious personal injury and property damage.</p>	

## 7.0 REFERENCE MATERIALS

**Ratings:** All glass bulbs are rated for temperatures from -67°F/-55°C.

### User Responsibility for Product Selection and Suitability

Each user bears final responsibility for making a determination as to the suitability of Victaulic products for a particular end-use application, in accordance with industry standards and project specifications, as well as Victaulic performance, maintenance, safety, and warning instructions. Nothing in this or any other document, nor any verbal recommendation, advice, or opinion from any Victaulic employee, shall be deemed to alter, vary, supersede, or waive any provision of Victaulic Company's standard conditions of sale, installation guide, or this disclaimer.

### Intellectual Property Rights

No statement contained herein concerning a possible or suggested use of any material, product, service, or design is intended, or should be construed, to grant any license under any patent or other intellectual property right of Victaulic or any of its subsidiaries or affiliates covering such use or design, or as a recommendation for the use of such material, product, service, or design in the infringement of any patent or other intellectual property right. The terms "Patented" or "Patent Pending" refer to design or utility patents or patent applications for articles and/or methods of use in the United States and/or other countries.

### Note

This product shall be manufactured by Victaulic or to Victaulic specifications. All products to be installed in accordance with current Victaulic installation/assembly instructions. Victaulic reserves the right to change product specifications, designs and standard equipment without notice and without incurring obligations.

### Installation

Reference should always be made to the Victaulic installation handbook or installation instructions of the product you are installing. Handbooks are included with each shipment of Victaulic products, providing complete installation and assembly data, and are available in PDF format on our website at [www.victaulic.com](http://www.victaulic.com).

### Warranty

Refer to the Warranty section of the current Price List or contact Victaulic for details.

### Trademarks

*Victaulic* and all other Victaulic marks are the trademarks or registered trademarks of Victaulic Company, and/or its affiliated entities, in the U.S. and/or other countries.



## TECHNICAL DATA

## FREEDOM® RESIDENTIAL HORIZONTAL SIDEWALL SPRINKLER VK486 (K4.0)

The Viking Corporation, 210 N Industrial Park Drive, Hastings MI 49058

Telephone: 269-945-9501 Technical Services: 877-384-5464 Fax: 269-818-1680 Email: techsvcs@vikingcorp.com

Visit the Viking website for the latest edition of this technical data page: [www.vikinggroupinc.com](http://www.vikinggroupinc.com)

### 1. DESCRIPTION

Viking Freedom® Residential Horizontal Sidewall Sprinkler VK486 is a small, thermostatic, glass-bulb residential sprinkler available in several different finishes and temperature ratings to meet varying design requirements. The Electroless Nickel PTFE (ENT) coating has been investigated for installation in corrosive atmospheres and is C-UL-US-EU Listed as corrosion resistant as indicated in the Approval Chart. The sprinkler orifice design, with a K-Factor of 4.0 (57.7 metric†), allows efficient use of available water supplies for the hydraulically designed fire-protection system. The glass bulb operating element and special deflector characteristics meet the challenges of residential sprinkler standards.

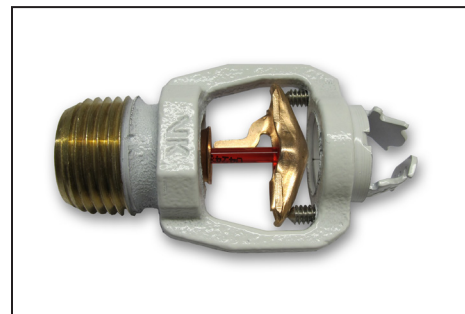

### 2. LISTINGS AND APPROVALS

 **UL Listed (C-UL-US-EU):** Category VKKW

 **VdS Approved**

 **WARNING:** Cancer and Reproductive Harm-  
[www.P65Warnings.ca.gov](http://www.P65Warnings.ca.gov)

Refer to the Approval Chart and Design Criteria for C-UL-US-EU Listing requirements that must be followed.

### 3. TECHNICAL DATA

#### Specifications:

Available since 2011.

Minimum Operating Pressure: Refer to the Approval Chart.

Maximum Working Pressure: 175 psi (12 bar). Factory tested hydrostatically to 500 psi (34.5 bar).

Thread size: 1/2" (15 mm) NPT

Nominal K-Factor: 4.0 U.S. (57.7 metric†)

† Metric K-factor measurement shown is in Bar. When pressure is measured in kPa, divide the metric K-factor shown by 10.0.

Glass-bulb fluid temperature rated to -65 °F (-55 °C)

Overall Length: 2-7/16" (62 mm)

Covered by the following US Patent numbers: 7,854,269 and 7,712,218

#### Material Standards:

Frame Casting: QM Brass and Brass UNS-C84400

Deflector: Phosphor Bronze UNS-C51000

Bulb: Glass, nominal 3 mm diameter

Belleville Spring Sealing Assembly: Nickel Alloy, coated on both sides with PTFE Tape

Pip Cap and Insert Assembly: Copper UNS-C11000 and Stainless Steel UNS-S30400

Compression Screws: 18-8 Stainless Steel

Yoke: Phosphor Bronze UNS-C51000

**Ordering Information:** (Also refer to the current Viking price list.)

**Sprinkler:** Base Part No. 17315

Order Sprinkler VK486 by first adding the appropriate suffix for the sprinkler finish and then the appropriate suffix for the temperature rating to the sprinkler base part number.

Finish Suffix: Brass = A, Chrome = F, White Polyester = M-/W, Black Polyester = M-/B

Temperature Suffix: 155 °F (68 °C) = B, 175 °F (79 °C) = D

For example, sprinkler VK486 with a Brass finish and a 155 °F (68 °C) temperature rating = Part No. 17315AB.

#### Available Finishes And Temperature Ratings:

Refer to Table 1.

**Accessories:** (Also refer to the Viking website.)

#### Sprinkler Wrenches:

A. Standard Wrench: Part No. 21475M/B (available since 2017)

B. Wrench for recessed sprinklers: Part No. 13655W/B\* (available since 2006)

\*A 1/2" ratchet is required (not available from Viking).



**TECHNICAL DATA**

**FREEDOM® RESIDENTIAL HORIZONTAL SIDEWALL SPRINKLER VK486 (K4.0)**

The Viking Corporation, 210 N Industrial Park Drive, Hastings MI 49058  
 Telephone: 269-945-9501 Technical Services: 877-384-5464 Fax: 269-818-1680 Email: techsvcs@vikingcorp.com  
 Visit the Viking website for the latest edition of this technical data page: www.vikinggroupinc.com

**Sprinkler Cabinets:**

- A. Six-head capacity: Part No. 01724A (available since 1971)
- B. Twelve-head capacity: Part No. 01725A (available since 1971)

**4. INSTALLATION**

Refer to appropriate NFPA Installation Standards.

**5. OPERATION**

During fire conditions, the heat-sensitive liquid in the glass bulb expands, causing the glass to shatter, releasing the yoke, pip cap, and sealing spring assembly. Water flowing through the sprinkler orifice strikes the sprinkler deflector, forming a uniform spray pattern to extinguish or control the fire.

**6. INSPECTIONS, TESTS AND MAINTENANCE**

Refer to NFPA 25 for Inspection, Testing and Maintenance requirements.

**7. AVAILABILITY**

Viking Sprinkler VK486 is available through a network of domestic and international distributors. See The Viking Corporation web site for the closest distributor or contact The Viking Corporation.

**8. GUARANTEE**

For details of warranty, refer to Viking's current list price schedule or contact Viking directly.

**TABLE 1: AVAILABLE SPRINKLER TEMPERATURE RATINGS AND FINISHES**

Sprinkler Temperature Classification	Sprinkler Nominal Temperature Rating <sup>1</sup>	Maximum Ambient Ceiling Temperature <sup>2</sup>	Bulb Color
Ordinary	155 °F (68 °C)	100 °F (38 °C)	Red
Intermediate	175 °F (79 °C)	150 °F (65 °C)	Yellow

**Sprinkler Finishes:** Brass, Chrome, White Polyester, and Black Polyester.

**Footnotes**

<sup>1</sup> The sprinkler temperature rating is stamped on the deflector.

<sup>2</sup> Based on NFPA-13. Other limits may apply, depending on fire loading, sprinkler location, and other requirements of the Authority Having Jurisdiction. Refer to specific installation standards.

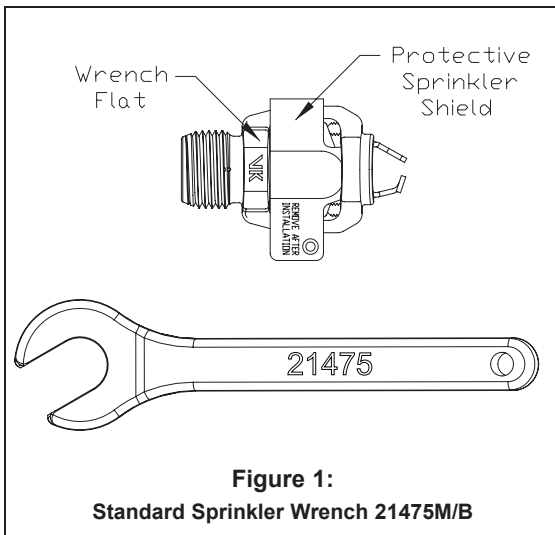

**Figure 1:**  
Standard Sprinkler Wrench 21475M/B

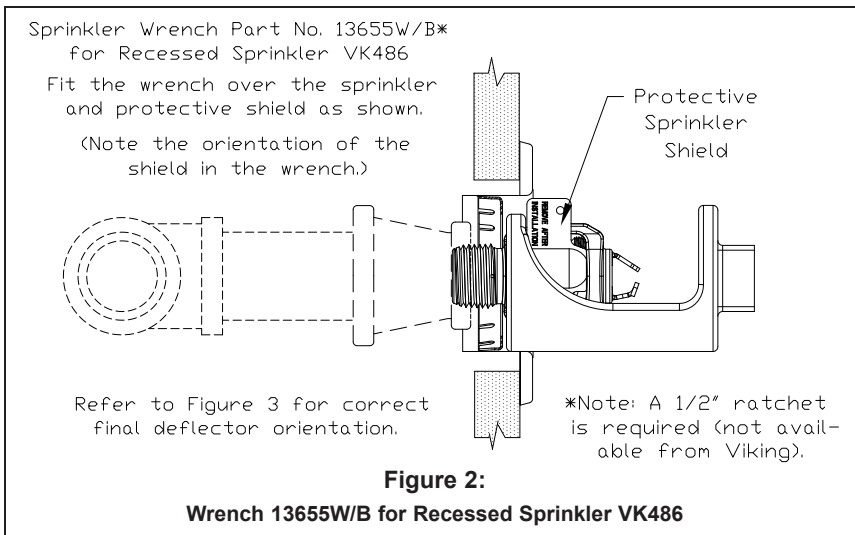

**Figure 2:**  
Wrench 13655W/B for Recessed Sprinkler VK486



## TECHNICAL DATA

## FREEDOM® RESIDENTIAL HORIZONTAL SIDEWALL SPRINKLER VK486 (K4.0)

The Viking Corporation, 210 N Industrial Park Drive, Hastings MI 49058  
 Telephone: 269-945-9501 Technical Services: 877-384-5464 Fax: 269-818-1680 Email: techsvcs@vikingcorp.com  
 Visit the Viking website for the latest edition of this technical data page: www.vikinggroupinc.com

### Approval Chart Viking VK486, 4.0 K-Factor Residential Horizontal Sidewall Sprinkler

For systems designed to NFPA 13D or NFPA 13R. For systems designed to NFPA 13, refer to the design criteria. For Ceiling types refer to current Editions of NFPA 13, 13R or 13D

Sprinkler Base Part Number <sup>1</sup>	SIN	NPT Thread Size		Nominal K-Factor		Maximum Water Working Pressure	Overall Length					
		Inches	mm	U.S.	metric <sup>2</sup>		Inches		mm			
17315	VK486	1/2	15	4.0	57.7	175 psi (12 bar)	2-7/16		62			
Max. Coverage Area <sup>3</sup> Width X Length Ft. X Ft. (m X m)	Max. Spacing Ft. (m)	Ordinary Temp Rating (155 °F/68 °C)		Intermediate Temp Rating (175 °F/79 °C)		Top of Deflector to Ceiling	Installation Type	Listings and Approvals <sup>4</sup>				Minimum Spacing Ft. (m)
		Flow <sup>3</sup> GPM (L/min)	Pressure <sup>3</sup> PSI (bar)	Flow <sup>3</sup> GPM (L/min)	Pressure <sup>3</sup> PSI (bar)			C-UL-US-EU <sup>5</sup>	VdS	NYC	NSF <sup>9</sup>	
12 X 12 (3.7 X 3.7)	12 (3.7)	11 (41.7)	7.6 (0.52)	11 (41.7)	7.6 (0.52)	4 to 6 inches	Standard surface-mounted escutcheons or recessed with the Micromatic® Model E-1, E-2, E-3, or G-1 Recessed Escutcheon	See Footnote 6 and 10.	See Footnote 6.	See Footnote 7.	See Footnote 6.	8 (2.4)
14 X 14 (4.3 X 4.3)	14 (4.3)	12 (45.5)	9 (0.62)	12 (45.5)	9 (0.62)							
16 X 16 (4.9 X 4.9)	16 (4.9)	13 (49.3)	10.6 (0.73)	13 (49.3)	10.6 (0.73)							
16 X 18 (4.9 X 5.5)	16 (4.9)	16 (60.6)	16 (1.10)	16 (60.6)	16 (1.10)							
16 X 20 (4.9 X 6.1)	16 (4.9)	22 (83.3)	30.3 (2.09)	22 (83.3)	30.3 (2.09)							
16 X 22 (4.9 X 6.7)	16 (4.9)	24 (90.8)	36 (2.48)	24 (90.8)	36 (2.48)							
18 X 18 (5.5 X 5.5)	18 (5.5)	18 (68.1)	20.3 (1.40)	19 (71.9)	22.6 (1.60)							
18 X 20 (5.5 X 6.1)	18 (5.5)	22 (83.3)	30.3 (2.09)	22 (83.3)	30.3 (2.09)							
12 X 12 (3.7 X 3.7)	12 (3.7)	12 (45.5)	9 (0.62)	12 (45.5)	9 (0.62)	6 to 12 inches						
14 X 14 (4.3 X 4.3)	14 (4.3)	12 (45.5)	9 (0.62)	13 (49.3)	10.6 (0.73)							
16 X 16 (4.9 X 4.9)	16 (4.9)	14 (53.0)	12.3 (0.84)	14 (53.0)	12.3 (0.84)							
16 X 18 (4.9 X 5.5)	16 (4.9)	16 (60.6)	16 (1.10)	16 (60.6)	16 (1.10)							
16 X 20 (4.9 X 6.1)	16 (4.9)	23 (87.1)	33.1 (2.28)	23 (87.1)	33.1 (2.28)							
16 X 22 (4.9 X 6.7)	16 (4.9)	26 (98.4)	42.3 (2.91)	26 (98.4)	42.3 (2.91)							
18 X 18 (5.5 X 5.5)	18 (5.5)	18 (68.1)	20.3 (1.40)	19 (71.9)	22.6 (1.60)							
18 X 20 (5.5 X 6.1)	18 (5.5)	23 (87.1)	33.1 (2.28)	23 (87.1)	33.1 (2.28)							
20 X 20 (6.1 X 6.1)	20 (6.1)	24 (90.8)	36 (2.48)	24 (90.8)	36 (2.48)							

#### Footnotes

- Part number shown is the base part number. For complete part number, refer to Viking's current price schedule.
- Metric K-factor measurement shown is when pressure is measured in Bar. When pressure is measured in kPa, divide the metric K-factor shown by 10.0.
- For areas of coverage smaller than shown, use the "Flow" and "Pressure" for the next larger area listed. Flows and pressures listed are per sprinkler. The distance from sprinklers to walls shall not exceed one-half the sprinkler spacing indicated for the minimum "Flow" and "Pressure" used.
- This chart shows the listings and approvals available at the time of printing. Other approvals may be in process. Check with the manufacturer for any additional approvals. Refer also to Design Criteria.
- Listed by Underwriter's Laboratories, Inc. for use in the U.S., Canada, and European Union.
- Approved Finishes are: Brass, Chrome, White Polyester, and Black Polyester <sup>8</sup>
- Meets New York City requirements, effective July 1, 2008.
- Other paint colors are available on request with the same C-UL-US-EU listings as the standard finish colors.
- UL Classified to : NSF/ANSI Standard 61, Drinking Water System Components (MH48034)
- Approved finish is Electroless Nickel PTFE (ENT). ENT is C-UL-US-EU Listed as corrosion resistant. ENT is available with standard surface-mounted escutcheons or the Micromatic Model E-1 Recessed Escutcheon.





**TECHNICAL DATA**

**FREEDOM® RESIDENTIAL HORIZONTAL SIDEWALL SPRINKLER VK486 (K4.0)**

The Viking Corporation, 210 N Industrial Park Drive, Hastings MI 49058  
 Telephone: 269-945-9501 Technical Services: 877-384-5464 Fax: 269-818-1680 Email: techsvcs@vikingcorp.com  
 Visit the Viking website for the latest edition of this technical data page: www.vikinggroupinc.com

**DESIGN CRITERIA**

(Also refer to the Approval Chart.)

**UL Listing Requirements (C-UL-US-EU):**

When using Viking Residential Horizontal Sidewall Sprinkler VK486 for systems designed to NFPA 13D or NFPA 13R, apply the listed areas of coverage and minimum water supply requirements shown in the Approval Chart.

For systems designed to NFPA 13: The number of design sprinklers is to be the four contiguous most hydraulically demanding sprinklers. The minimum required discharge from each of the four sprinklers is to be the greater of the following:

- The flow rates given in the Approval Chart for NFPA 13D and NFPA 13R applications for each listed area of coverage, **or**
- Calculated based on a minimum discharge of 0.1 gpm/sq. ft. over the “design area” in accordance with sections 8.5.2.1 or 8.6.2.1.2 of NFPA 13.
- Minimum distance between residential sprinklers: 8 ft. (2.4 m).
- The VK486 horizontal sidewall sprinkler deflector shall be located a minimum of 1-1/4” (31.8 mm) and a maximum of 6” (152 mm) from the wall on which it is installed.

**DEFLECTOR POSITION:** Install sprinkler VK486 with the leading edge of the deflector oriented parallel to the ceiling and the sprinkler frame arms oriented perpendicular to the ceiling (see Figure 4). **THE TOP SURFACE OF THE DEFLECTOR IS MARKED “TOP”.** The sprinkler must be oriented as shown in Figure 3 below.

**IMPORTANT: Always refer to Bulletin Form No. F\_091699 - Care and Handling of Sprinklers. Also refer to Form No. F\_080190, F\_080814, and F\_080415 for general care, installation, and maintenance information. Viking sprinklers are to be installed in accordance with the latest edition of Viking technical data, the appropriate standards of NFPA and any other similar Authorities Having Jurisdiction, and also with the provisions of governmental codes, ordinances, and standards, whenever applicable. Final approval and acceptance of all residential sprinkler installations must be obtained from the Authorities Having Jurisdiction.**

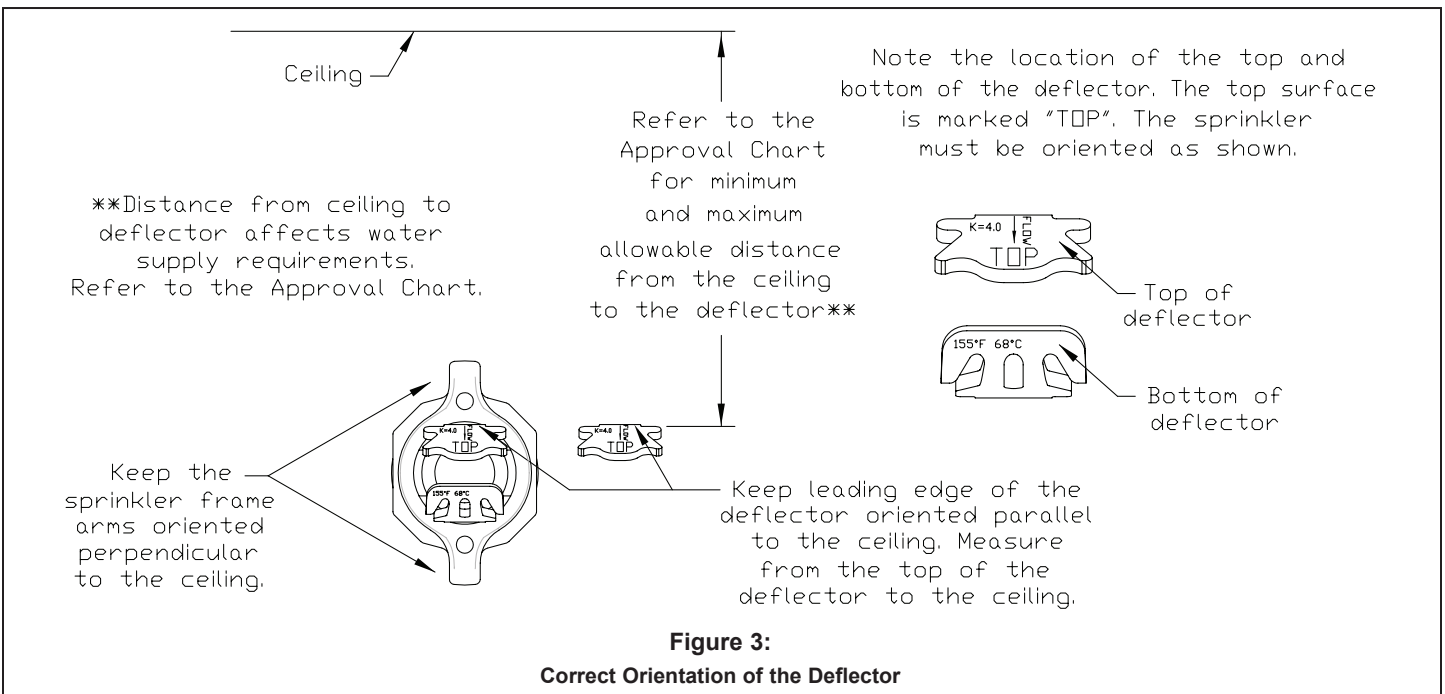



**TECHNICAL DATA**

**FREEDOM® RESIDENTIAL  
HORIZONTAL SIDEWALL  
SPRINKLER VK486 (K4.0)**

The Viking Corporation, 210 N Industrial Park Drive, Hastings MI 49058  
 Telephone: 269-945-9501 Technical Services: 877-384-5464 Fax: 269-818-1680 Email: techsvcs@vikingcorp.com  
 Visit the Viking website for the latest edition of this technical data page: www.vikinggroupinc.com

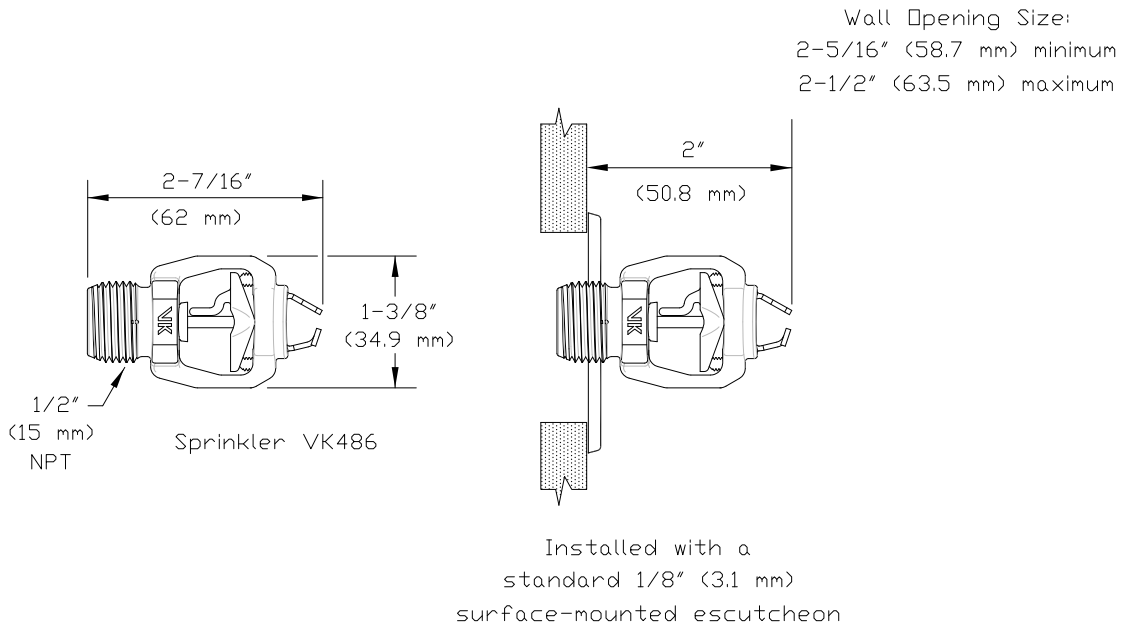

**Figure 4:**  
**Sprinkler VK486 Dimensions with a Standard Escutcheon and the Model F-1 Adjustable Escutcheon**

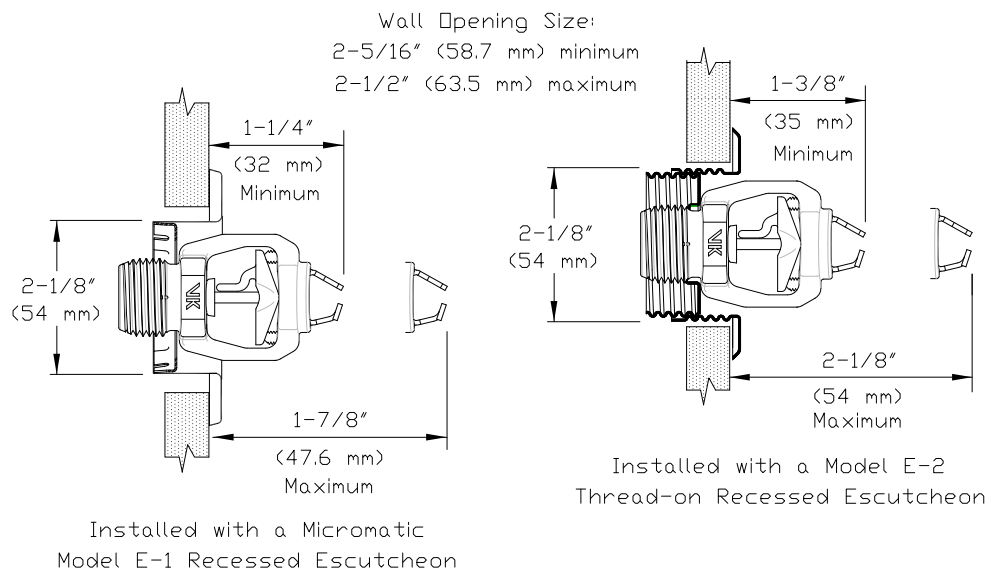

**Figure 5:**  
**Sprinkler VK486 Dimensions with the Model E-1 and E-2 Recessed Escutcheons**



TECHNICAL DATA

FREEDOM® RESIDENTIAL HORIZONTAL SIDEWALL SPRINKLER VK486 (K4.0)

The Viking Corporation, 210 N Industrial Park Drive, Hastings MI 49058  
Telephone: 269-945-9501 Technical Services: 877-384-5464 Fax: 269-818-1680 Email: techsvcs@vikingcorp.com  
Visit the Viking website for the latest edition of this technical data page: www.vikinggroupinc.com

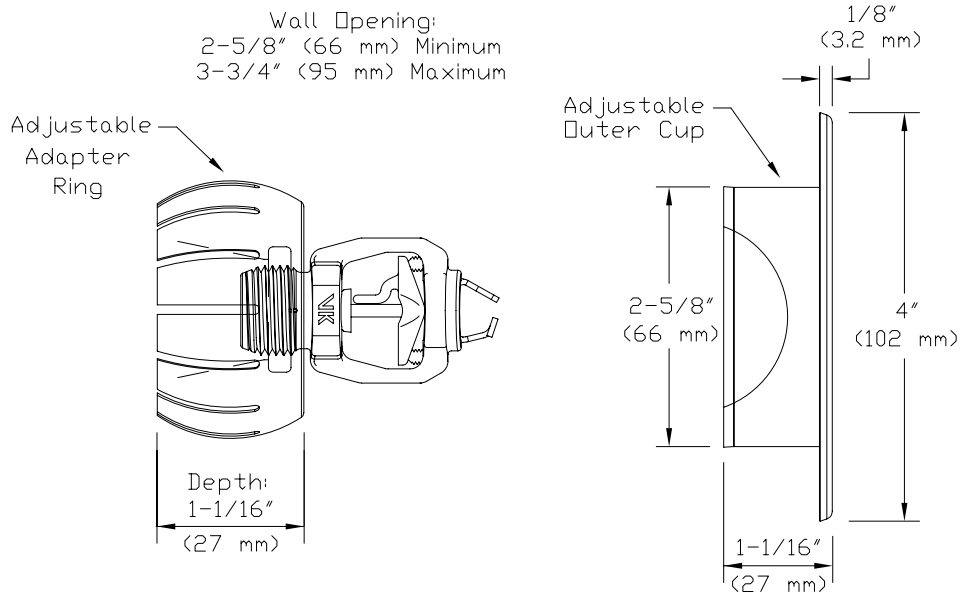

Figure 6: Sprinkler VK486 Dimensions with the Model G-1 Escutcheon

**Plans APPROVED by Fire Marshal**

- Fire Marshal field inspection REQUIRED for final approval.
- No inspection without approved, color-print plans onsite.
- Approval of this plan does not constitute approval to omit, amend, or otherwise not comply with any of the provisions in the adopted codes, standards, or manufacturer's installation requirements.

Date: 07/15/2020  
 Reviewed by: M. Long  
 Permit #: Multiple Permits

AP#:  
 201840100  
 201840102  
 201840103  
 201840105  
 201840107  
 201840108

58" (4'-10") MAXIMUM LENGTH OF THE FLEX DRY BARREL, PER THE MANUFACTURER. DASHED SPRINKLER LINES INDICATE FLEX PIPING.

FOR TYPICAL HYDRAULIC CALCULATION INFORMATION FOR THIS MODEL HOUSE, SEE SHEET 6 OF 8.

ONLY NIBCO 5012-S-BI CPVC TEE TO BE USED ON DRY SPRINKLER HEADS.

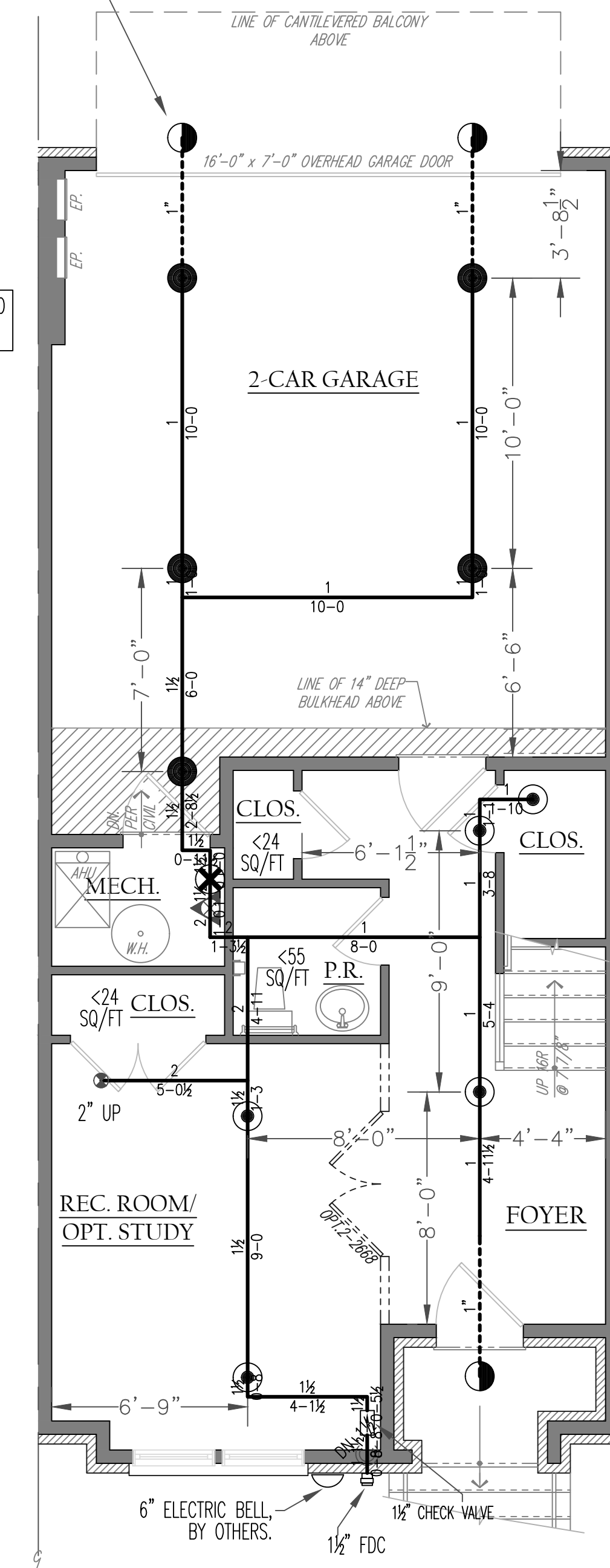

GROUND FLOOR PLAN

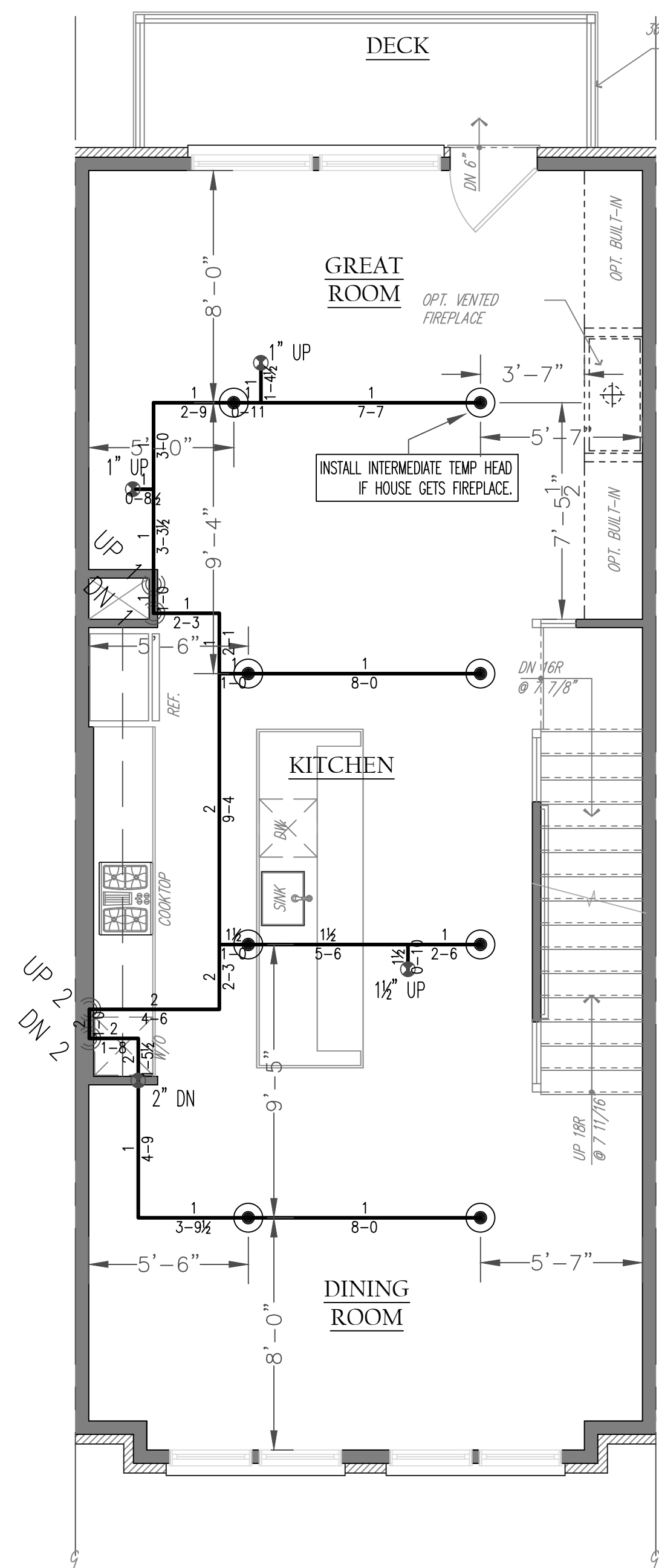

SECOND FLOOR PLAN

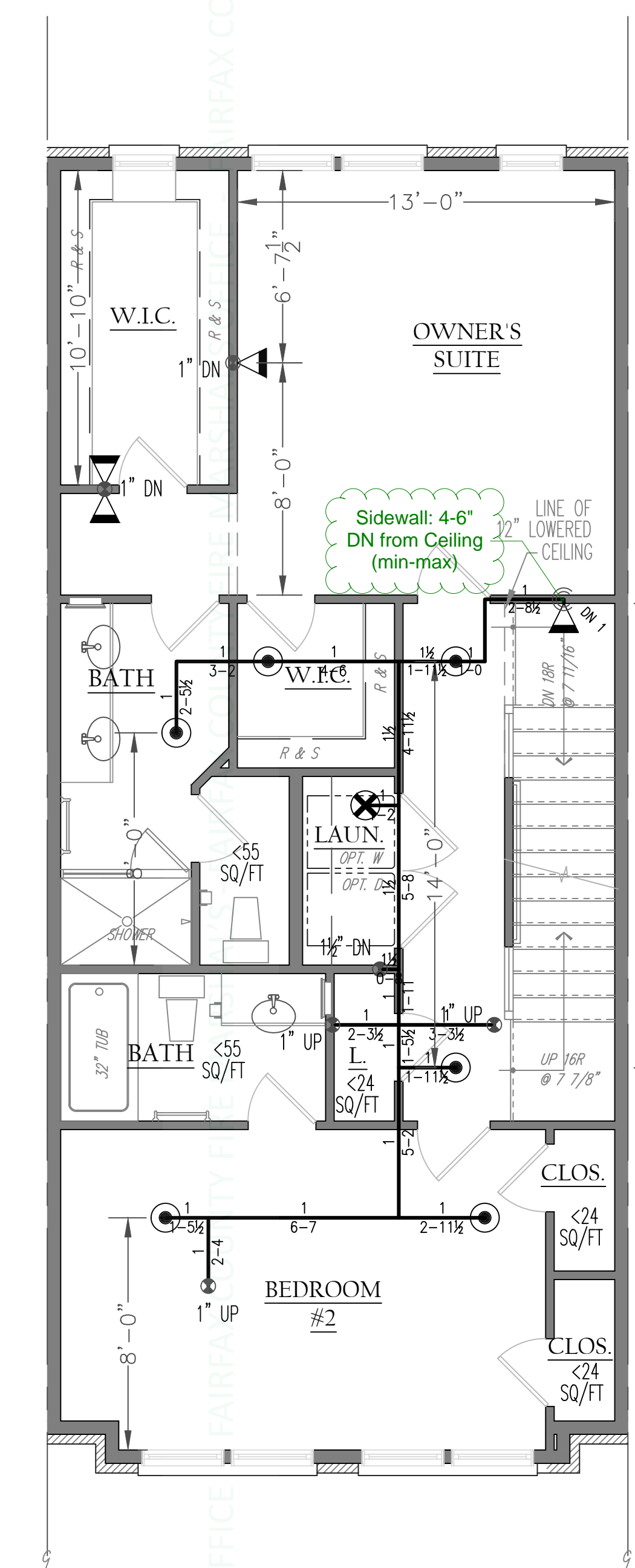

THIRD FLOOR PLAN

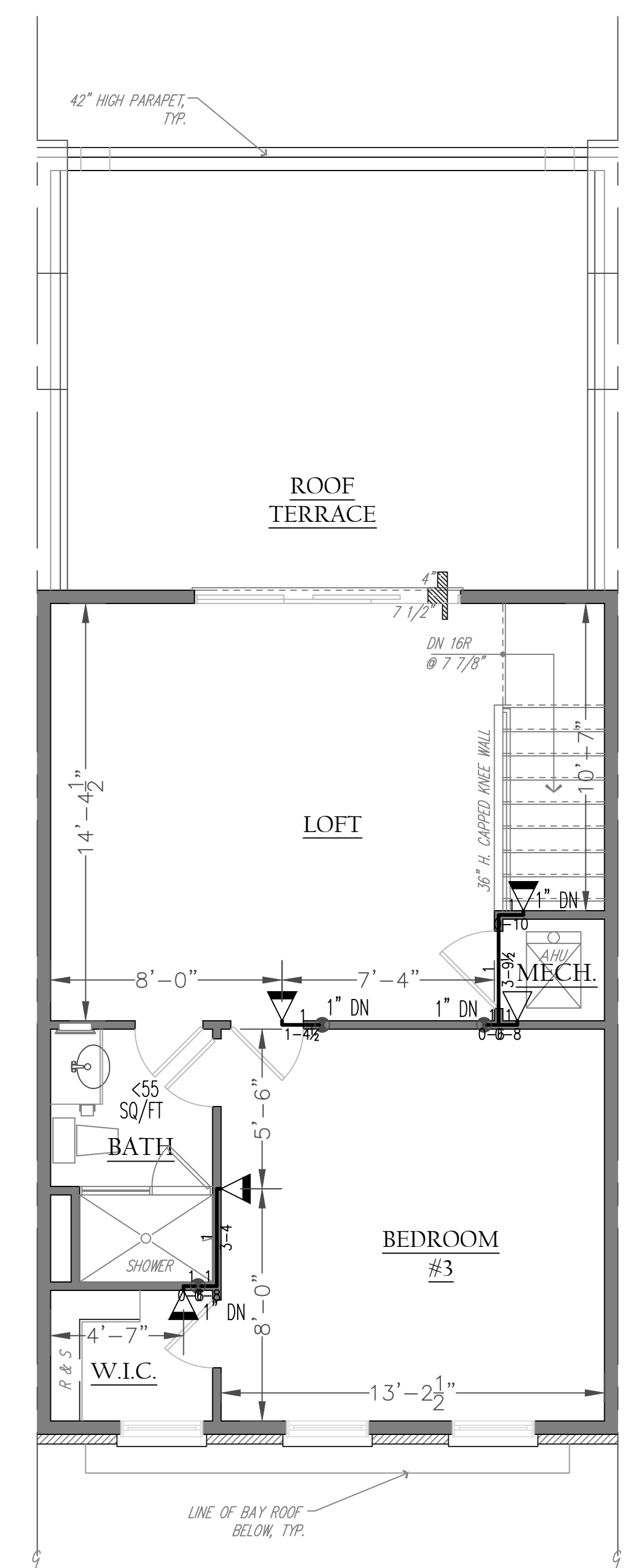

LOFT FLOOR PLAN

**GENERAL NOTE**  
 "Sprinklers are not required when multiple bathrooms are adjacent to each other and are considered separate rooms, provided they contain a lintel of a minimum of 8" and they are dedicated to personal hygiene, or a water closet, or bathing capability such as a shower or tub, or any combination of facilities thereof. NFPA #13R, 2016 was used as a future reference guide for clarification."

**CEILING HEIGHTS (UNLESS NOTED OTHERWISE)**  
 1ST FLOOR - 9'-1 1/8"  
 2ND FLOOR - 10'-1 1/8"  
 3RD FLOOR - 9'-1 1/8"  
 4TH FLOOR - 9'-1 1/8"

**MAXIMUM SPACING OF ALL RESIDENTIAL SPRINKLERS**

PENDENT HEADS: 16' X 16' AND 8' FROM WALL, W/ DEFLECTOR 1" TO 4" FROM CEILING

SIDEWALL HEADS: 16' X 16' AND 8' FROM WALL, W/ DEFLECTOR 4" TO 6" FROM CEILING

DRY PENDENT HEADS: 14' X 14' AND 7' FROM WALL, W/ DEFLECTOR 1" TO 4" FROM CEILING

FLEX DRY PENDENT HEADS: 14' X 14' AND 7' FROM WALL, W/ DEFLECTOR 1" TO 4" FROM CEILING

SPRINKLERS		DESIGN CRITERIA		SPECIALTY ITEMS		SYMBOLS		ABBREVIATIONS		PLAN REVISIONS		
SYMBOL	MANUF./MODEL	TEMP.	FINISH	TOTAL	NFPA REF. #	ALR	FLOW TEST:	STATIC PSI	RESIDUAL PSI	TYPE	SIZE	
○	1/2" REG. PEND.	155 DEG	WHITE	19	TYPE	NET	TYPE	TYPE	TYPE	TYPE	TYPE	
⊗	1/2" REG. SIDEWALL	155 DEG	WHITE	2	HAZARD:	LIGHT HAZARD	TYPE	TYPE	TYPE	TYPE	TYPE	
⊕	1/2" REG. SIDEWALL	155 DEG	WHITE	8	DENSITY:	.05, .10	TYPE	TYPE	TYPE	TYPE	TYPE	
▽	1/2" REG. PEND.	155 DEG	WHITE	1	REMOTE AREA:	2-4 HEADS	TYPE	TYPE	TYPE	TYPE	TYPE	
⊙	1/2" DRY PEND.	155 DEG	WHITE	5	MAX. S.F./ADJ.	100, 200	TYPE	TYPE	TYPE	TYPE	TYPE	
⊖	1/2" DRY PEND.	155 DEG	WHITE	3	K FACTOR:	4.0-5.0	TYPE	TYPE	TYPE	TYPE	TYPE	
⊙	1/2" DRY PEND.	155 DEG	WHITE	38	C FACTOR:	120 - 150	TYPE	TYPE	TYPE	TYPE	TYPE	
					INSIDE HOSE:	N/A	TYPE	TYPE	TYPE	TYPE	TYPE	
					OUTSIDE HOSE:		TYPE	TYPE	TYPE	TYPE	TYPE	
JOB TOTAL				38								
TOTAL THIS SHEET				38								
OF				8								

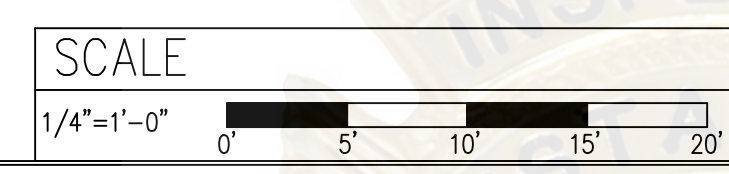

SCALE: 1/4"=1'-0"

JOB NAME: FARADAY PARK, 1870 EASTERLY RD., RESTON, VA. 20190

DATE: 6-25-2020  
 PLAN NORTH  
 AREA: LOT 3  
 PERMIT NO: 200580056

SCALE: 1/4"=1'-0"  
 CONTRACT NO: 20-0073  
 DRAWN BY: CMS  
 REVIEWED BY:  
 CAD FILE: FARADAYSUBMIT

APPROVALS: FAIRFAX COUNTY F.M.O.  
 CONTRACTOR: KNUTSON COMPANIES  
 CONTRACTOR PHONE: 703-996-4246

DRWG NO: 1 OF 8

**BUILDERS FIRE SOLUTIONS**  
 225 ELM STREET, WARRENTON, VA 20186 (540) 428-8712  
 AUTOMATIC FIRE PROTECTION SYSTEMS  
 DESIGN INSTALLATION SERVICE

Plans  
APPROVED  
by Fire Marshal

Date: 07/15/2020  
Permit #: Multiple Permits

AP#:  
201840100  
201840102  
201840103  
201840105  
201840107  
201840108

58" (4'-10") MAXIMUM LENGTH OF THE FLEX DRY BARREL, PER THE MANUFACTURER. DASHED SPRINKLER LINES INDICATE FLEX PIPING.

FOR TYPICAL HYDRAULIC CALCULATION INFORMATION FOR THIS MODEL HOUSE, SEE SHEET 6 OF 8.

ONLY NIBCO 5012-S-BI CPVC TEE TO BE USED ON DRY SPRINKLER HEADS.

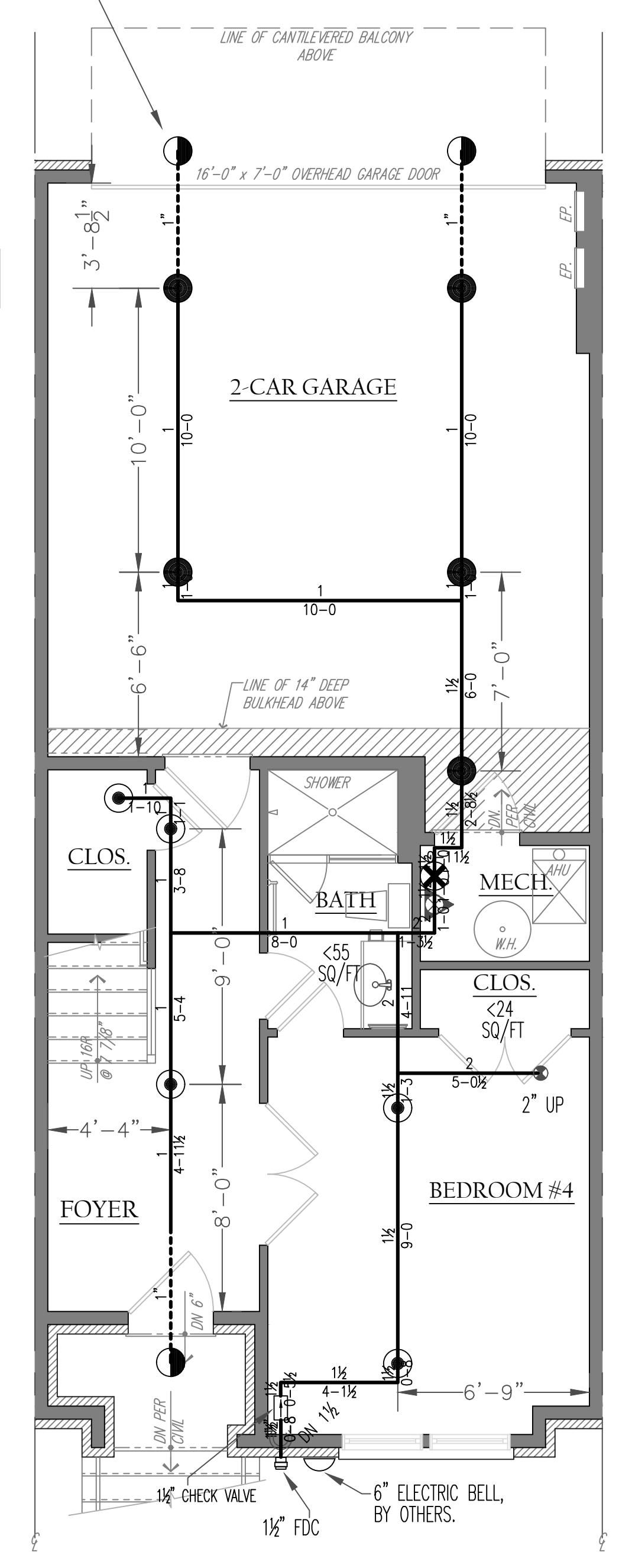

GROUND FLOOR PLAN

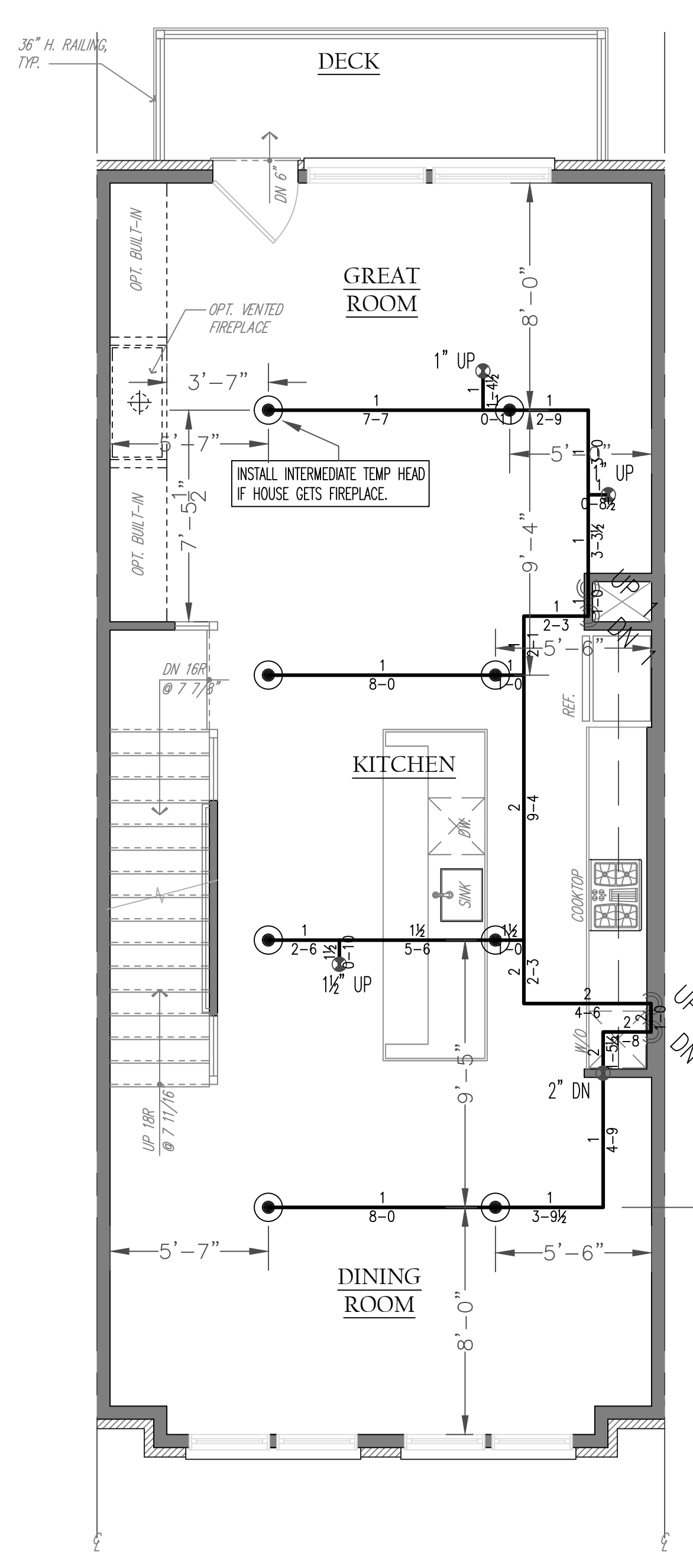

SECOND FLOOR PLAN

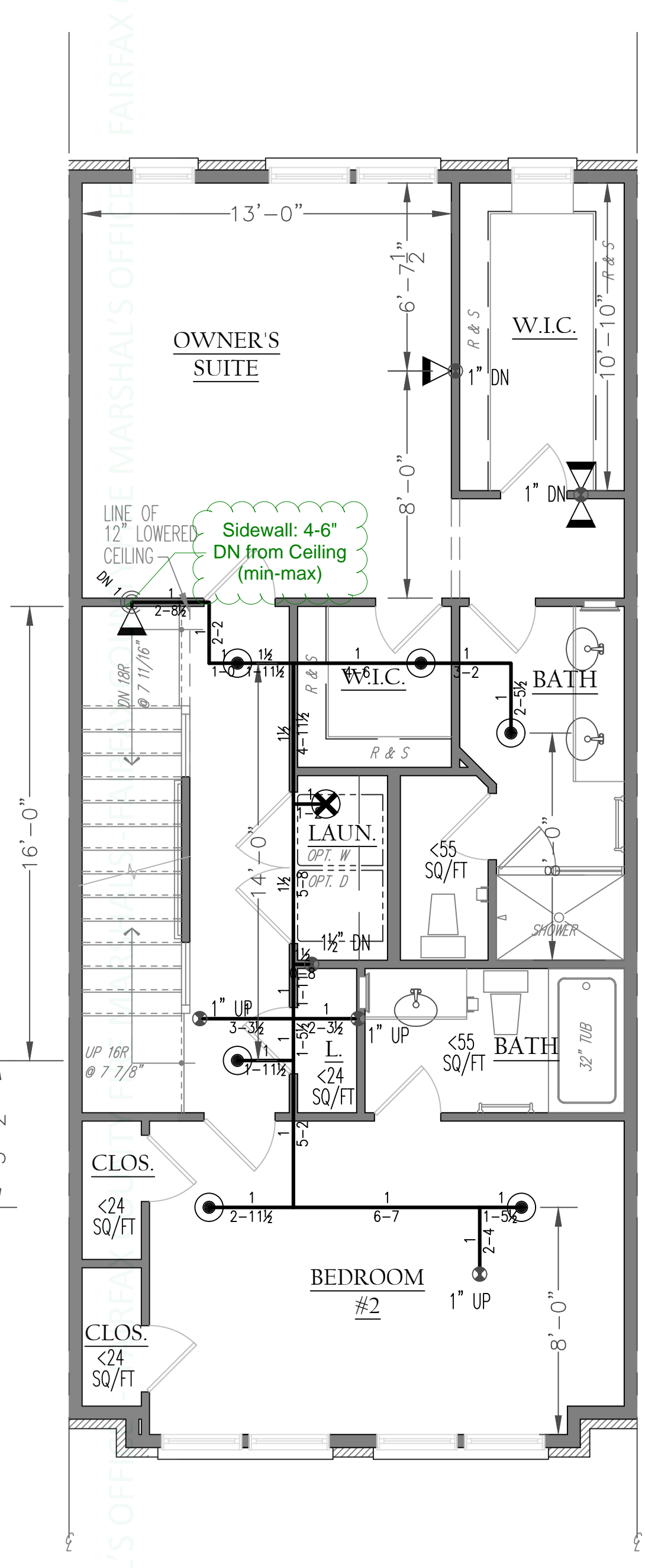

THIRD FLOOR PLAN

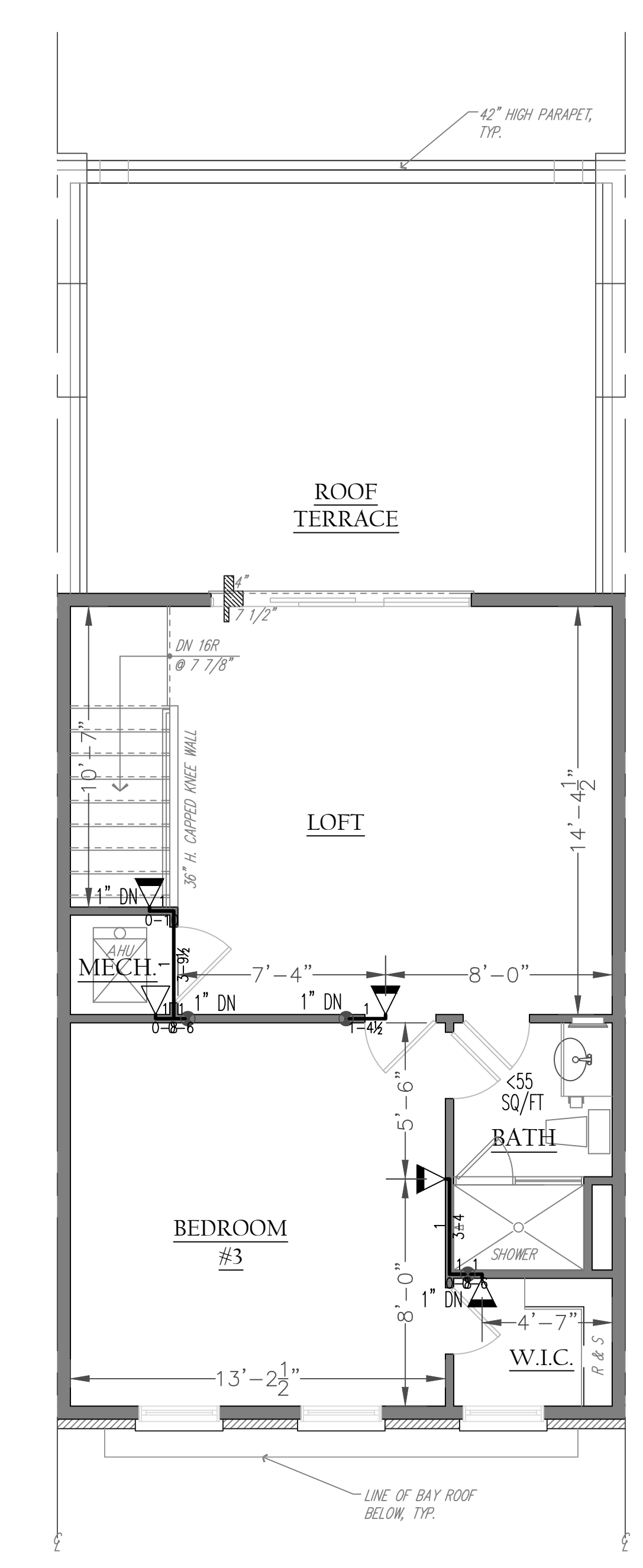

LOFT FLOOR PLAN

**GENERAL NOTE**  
Sprinklers are not required when multiple bathrooms are adjacent to each other and are considered separate rooms, provided they contain a lintel of a minimum of 8" and they are dedicated to personal hygiene, or a water closet, or bathing capability such as a shower or tub, or any combination of facilities thereof. NFPA #13R, 2016 was used as a future reference guide for clarification.

**CEILING HEIGHTS (UNLESS NOTED OTHERWISE)**  
1ST FLOOR - 9'-1 1/8"  
2ND FLOOR - 10'-1 1/8"  
3RD FLOOR - 9'-1 1/8"  
4TH FLOOR - 9'-1 1/8"

**MAXIMUM SPACING OF ALL RESIDENTIAL SPRINKLERS**  
PENDENT HEADS: 16' X 16' AND 8' FROM WALL, W/ DEFLECTOR 1" TO 4" FROM CEILING  
SIDEWALL HEADS: 16' X 16' AND 8' FROM WALL, W/ DEFLECTOR 4" TO 6" FROM CEILING  
DRY PENDENT HEADS: 14' X 14' AND 7' FROM WALL, W/ DEFLECTOR 1" TO 4" FROM CEILING  
FLEX DRY PENDENT HEADS: 14' X 14' AND 7' FROM WALL, W/ DEFLECTOR 1" TO 4" FROM CEILING

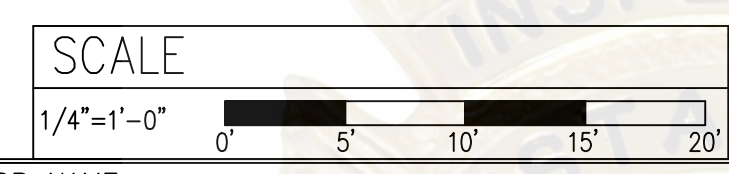

JOB NAME: FARADAY PARK  
1872 EASTERLY RD.  
RESTON, VA. 20190

DATE: 6-25-2020  
SCALE: 1/4"=1'-0"  
PLAN NORTH  
DRAWN BY: CMS  
AREA: LOT 4  
PERMIT NO: 200580057

CONTRACT NO: 20-0073  
REVIEWED BY:  
CAD FILE:  
CONTRACTOR PHONE: 703-996-4246

APPROVALS: FAIRFAX COUNTY F.M.O.  
CONTRACTOR: KNUTSON COMPANIES  
CAD FILE: FARADAYSUBMIT  
DRWG NO: 2 OF 8

**BUILDERS FIRE SOLUTIONS**  
225 ELM STREET, WARRENTON, VA 20186 (540) 428-8712  
AUTOMATIC FIRE PROTECTION SYSTEMS  
DESIGN INSTALLATION SERVICE

SPRINKLERS		DESIGN CRITERIA		SPECIALTY ITEMS		SYMBOLS		ABBREVIATIONS		PLAN REVISIONS	
SYMBOL	MANUF./MODEL	TEMP. FINISH	TOTAL	NFPA REF. #	TYPE	FLOW TEST:	F.D.C.:	TYPE	TYPE	DESCRIPTION	DATE
○	1/2" REC. PEND.	155 DEG	19	TYPE SPS.	NET	STATIC PSI	1/2"-0"	RESIDUAL PSI	CLG	CEILING	
○	1/2" REC. PEND.	175 DEG	2	HAZARD	LIGHT INADJ.	RESIDUAL PSI	1/2"-0"	RESIDUAL PSI	UNO	UNLESS NOTED OTHERWISE	
○	1/2" REC. SIDEWALL WING	155 DEG	8	DENSITY	.05, .10	FLOW	1/2"-0"	FLOW	UH	UNIT HEATER	
○	1/2" REC. SIDEWALL WING	175 DEG	2	REMOVE AREA	2-4 HEADS	HYDRANT ELEV.	1/2"-0"	HYDRANT ELEV.	UH	UNIT HEATER	
○	1/2" DRY PEND.	155 DEG	5	MAX. S.F./HD.	104, 206	HYD. LOW GRAD.	1/2"-0"	HYD. LOW GRAD.	CB	CYSPSM BOARD	
○	1/2" DRY PEND.	175 DEG	3	K FACTOR:	4.0-5.6	HYD. HIGH GRAD.	1/2"-0"	HYD. HIGH GRAD.	CB	CYSPSM BOARD	
○	1/2" DRY PEND.	155 DEG	3	C FACTOR:	120 - 150	ADJ. STATIC PSI	1/2"-0"	ADJ. STATIC PSI	CB	CYSPSM BOARD	
○	1/2" DRY PEND.	175 DEG	3	INSIDE HOSE	N/A	INFO BY	1/2"-0"	INSIDE HOSE	CB	CYSPSM BOARD	
○	1/2" DRY PEND.	155 DEG	38	INSIDE HOSE	N/A	INFO BY	1/2"-0"	INSIDE HOSE	CB	CYSPSM BOARD	
○	1/2" DRY PEND.	175 DEG	38	INSIDE HOSE	N/A	INFO BY	1/2"-0"	INSIDE HOSE	CB	CYSPSM BOARD	

Plans  
APPROVED  
by Fire Marshal

Date: 07/15/2020  
Permit #: Multiple Permits

AP#:  
201840100  
201840102  
201840103  
201840105  
201840107  
201840108

58" (4'-10") MAXIMUM LENGTH OF THE FLEX DRY BARREL, PER THE MANUFACTURER. DASHED SPRINKLER LINES INDICATE FLEX PIPING.

FOR TYPICAL HYDRAULIC CALCULATION INFORMATION FOR THIS MODEL HOUSE, SEE SHEET 6 OF 8.

ONLY NIBCO S012-S-BI CPVC TEE TO BE USED ON DRY SPRINKLER HEADS.

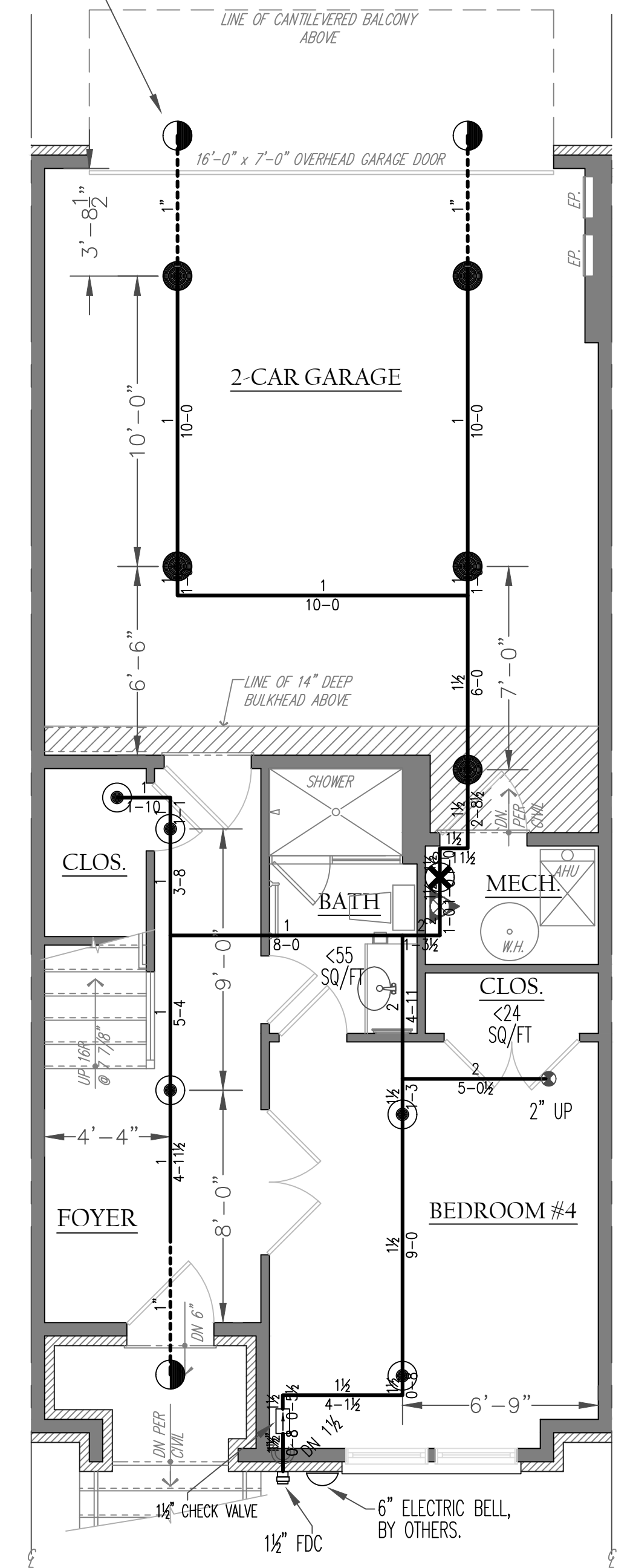

GROUND FLOOR PLAN

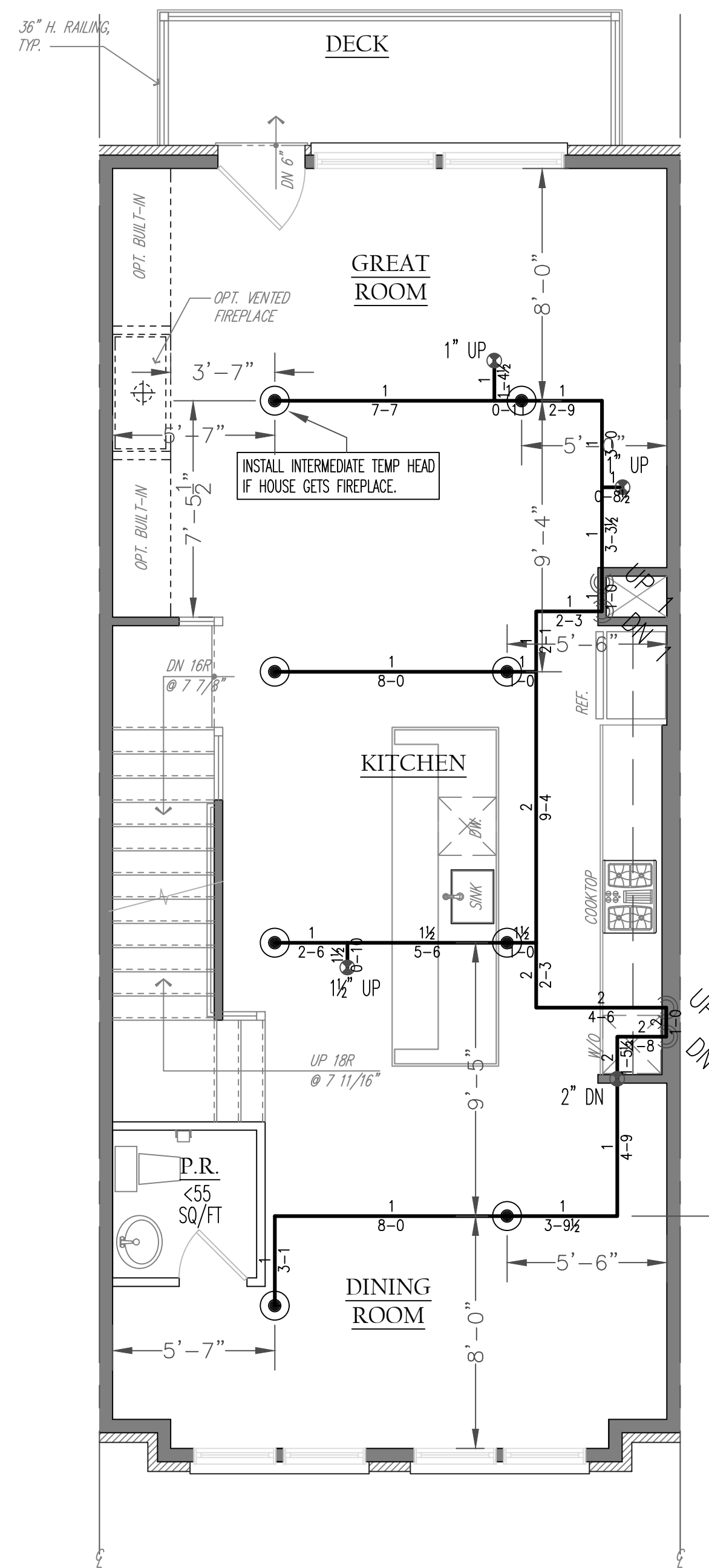

SECOND FLOOR PLAN

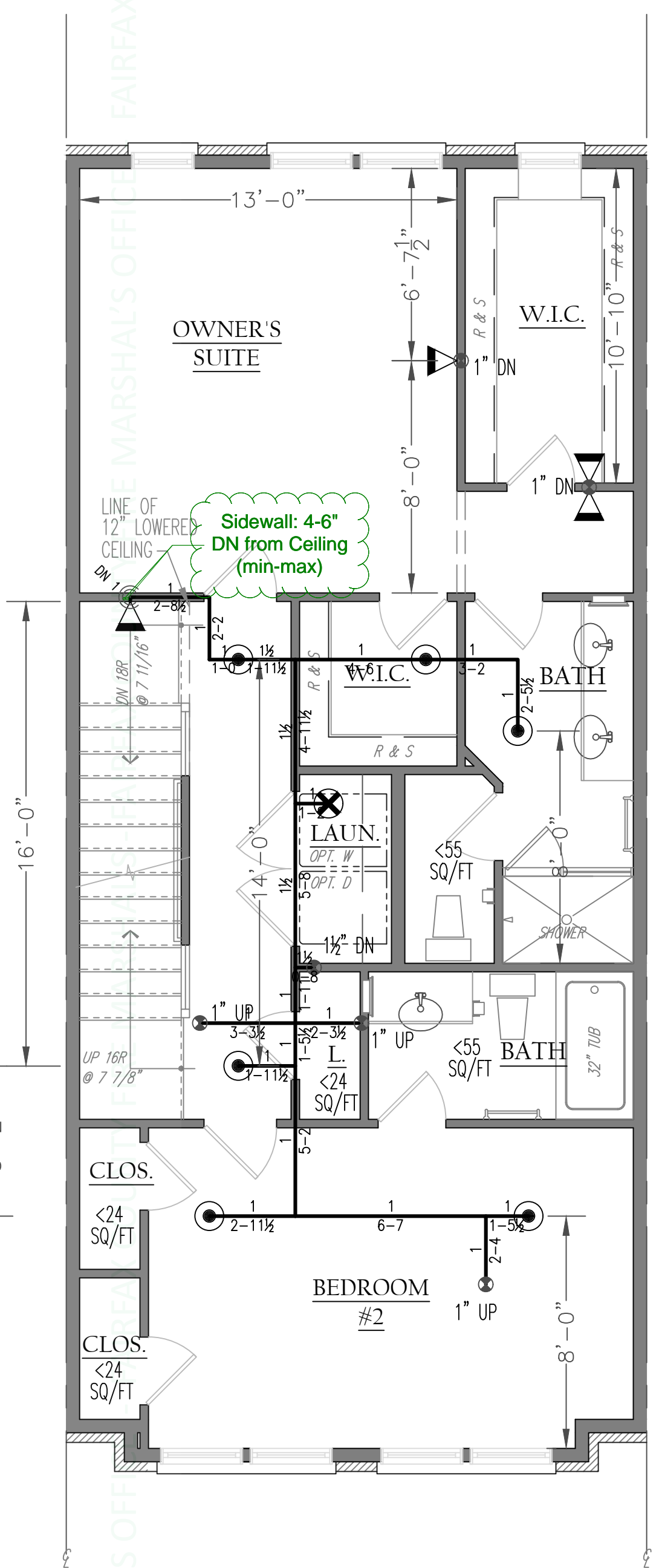

THIRD FLOOR PLAN

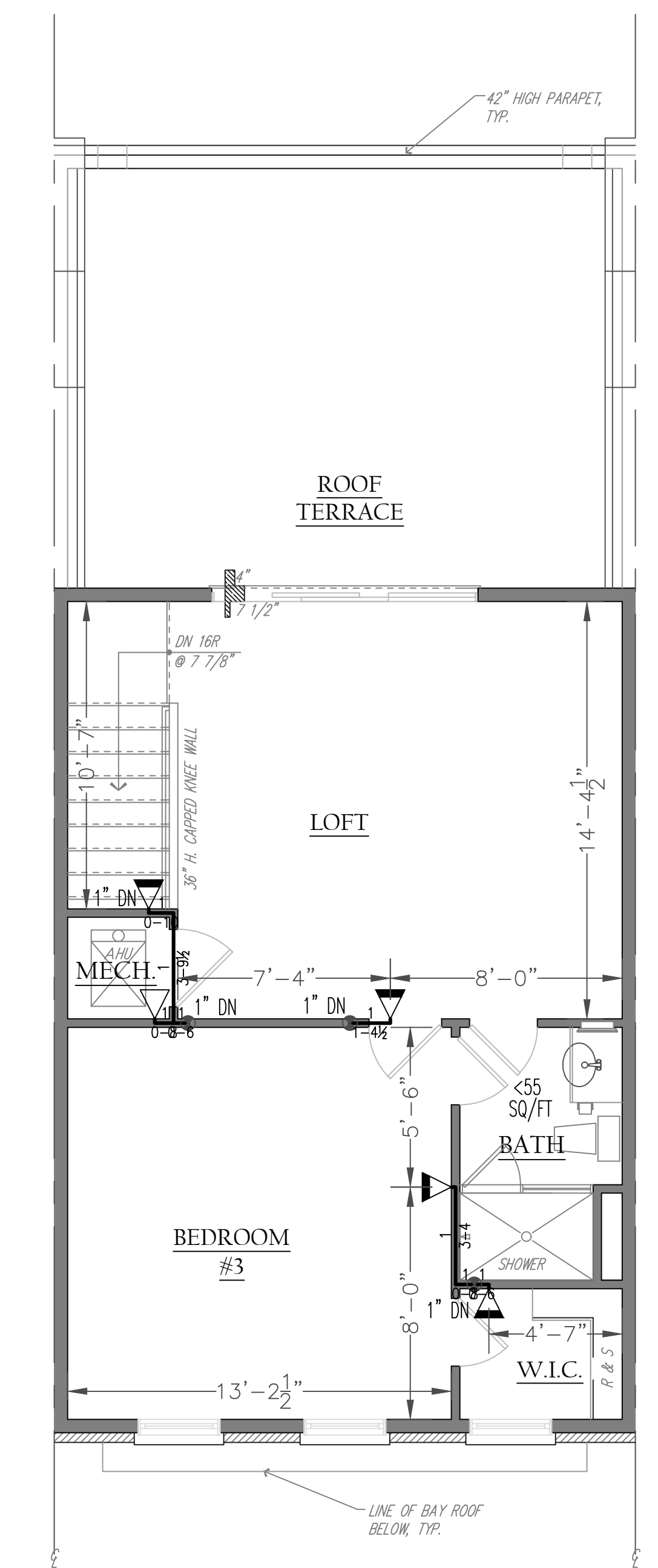

LOFT FLOOR PLAN

**GENERAL NOTE**  
Sprinklers are not required when multiple bathrooms are adjacent to each other and are considered separate rooms, provided they contain a lintel of a minimum of 8" and they are dedicated to personal hygiene, or a water closet, or bathing capability such as a shower or tub, or any combination of facilities thereof. NFPA #13R, 2016 was used as a future reference guide for clarification.

**CEILING HEIGHTS (UNLESS NOTED OTHERWISE)**  
1ST FLOOR - 9'-1 1/8"  
2ND FLOOR - 10'-1 1/8"  
3RD FLOOR - 9'-1 1/8"  
4TH FLOOR - 9'-1 1/8"

**MAXIMUM SPACING OF ALL RESIDENTIAL SPRINKLERS**  
PENDENT HEADS: 16' X 16' AND 8' FROM WALL, W/ DEFLECTOR 1" TO 4" FROM CEILING  
SIDEWALL HEADS: 16' X 16' AND 8' FROM WALL, W/ DEFLECTOR 4" TO 6" FROM CEILING  
DRY PENDENT HEADS: 14' X 14' AND 7' FROM WALL, W/ DEFLECTOR 1" TO 4" FROM CEILING  
FLEX DRY PENDENT HEADS: 14' X 14' AND 7' FROM WALL, W/ DEFLECTOR 1" TO 4" FROM CEILING

SPRINKLERS		DESIGN CRITERIA		SPECIALTY ITEMS		SYMBOLS		ABBREVIATIONS		PLAN REVISIONS			
SYMBOL	MANUF/MODEL	TEMP. FINISH	TOTAL	NFPA REF. #	FLSR	TYPE	FLOW TEST	F.D.C.E.	TYPE	FINISH	DATE	BY	DESCRIPTION
○	1/2" REC. PEND.	WHITE	19	TYPE SFS	NET	STATIC PSI	RESIDUAL PSI	CLG	CEILING	UNO	UNLESS NOTED OTHERWISE		
○	1/2" REC. PEND.	WHITE	2	HAZARD	LIGHT INWARD	RESIDUAL PSI	RESIDUAL PSI	UH	UNIT HEATER	UH			
○	1/2" REC. SIDEWALL WING	WHITE	8	DENSITY	.05, .10	FLOW	FLOW	UB	UNITS BOARD	UB			
○	1/2" REC. SIDEWALL WING	WHITE	5	REMOTE AREA	2-4 HEADS	HYDRANT ELEV.	HYDRANT ELEV.	AT	ACCOUSTICAL TILE CEILING	AT			
○	1/2" REC. PEND.	WHITE	3	MAX. S.F./HD.	104, 206	HYD. LOW GRAD.	HYD. LOW GRAD.	CF	OUT IN FIELD	CF			
○	1/2" FLEX DRY PEND.	WHITE	3	K FACTOR	4.0-5.6	HYD. HIGH GRAD.	HYD. HIGH GRAD.	CL	CENTER LINE	CL			
○	1/2" FLEX DRY PEND.	WHITE	3	C FACTOR	120 - 150	ADJ. STATIC PSI	ADJ. STATIC PSI	BE	BELOW BECK	BE			
○	1/2" FLEX DRY PEND.	WHITE	3	INSIDE HOSE	N/A	INFO BY	INFO BY	AF	BELOW FINISHED FLOOR	AF			
○	1/2" FLEX DRY PEND.	WHITE	3	INSIDE HOSE	N/A	INFO BY	INFO BY	TP	TYPICAL	TP			
JOB TOTAL			38										
TOTAL THIS SHEET			38										

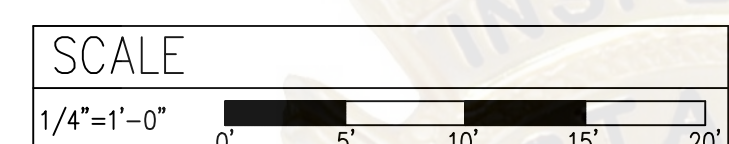

JOB NAME: FARADAY PARK  
1874 EASTERLY RD.  
RESTON, VA. 20190

DATE: 6-25-2020  
SCALE: 1/4"=1'-0"  
PLAN NORTH

CONTRACT NO: 20-0073  
FAIRFAX COUNTY F.M.O.

APPROVALS: [Signature]

CONTRACTOR: KNUTSON COMPANIES

AREA: LOT 5  
CAD FILE: FARADAYSUBMIT

PERMIT NO: 200580058  
CONTRACTOR PHONE: 703-996-4246

DRWG NO: 3 OF 8

**BUILDERS FIRE SOLUTIONS**  
225 ELM STREET, WARRENTON, VA 20186 (540) 428-8712  
AUTOMATIC FIRE PROTECTION SYSTEMS  
DESIGN INSTALLATION SERVICE



Plans  
APPROVED  
by Fire Marshal

Date: 07/15/2020  
Permit #: Multiple Permits

AP#: 201840100  
201840102  
201840103  
201840105  
201840107  
201840108

58" (4'-10") MAXIMUM LENGTH OF THE FLEX DRY BARREL, PER THE MANUFACTURER. DASHED SPRINKLER LINES INDICATE FLEX PIPING.

FOR TYPICAL HYDRAULIC CALCULATION INFORMATION FOR THIS MODEL HOUSE, SEE SHEET 6 OF 8.

ONLY NIBCO 5012-S-BI CPVC TEE TO BE USED ON DRY SPRINKLER HEADS.

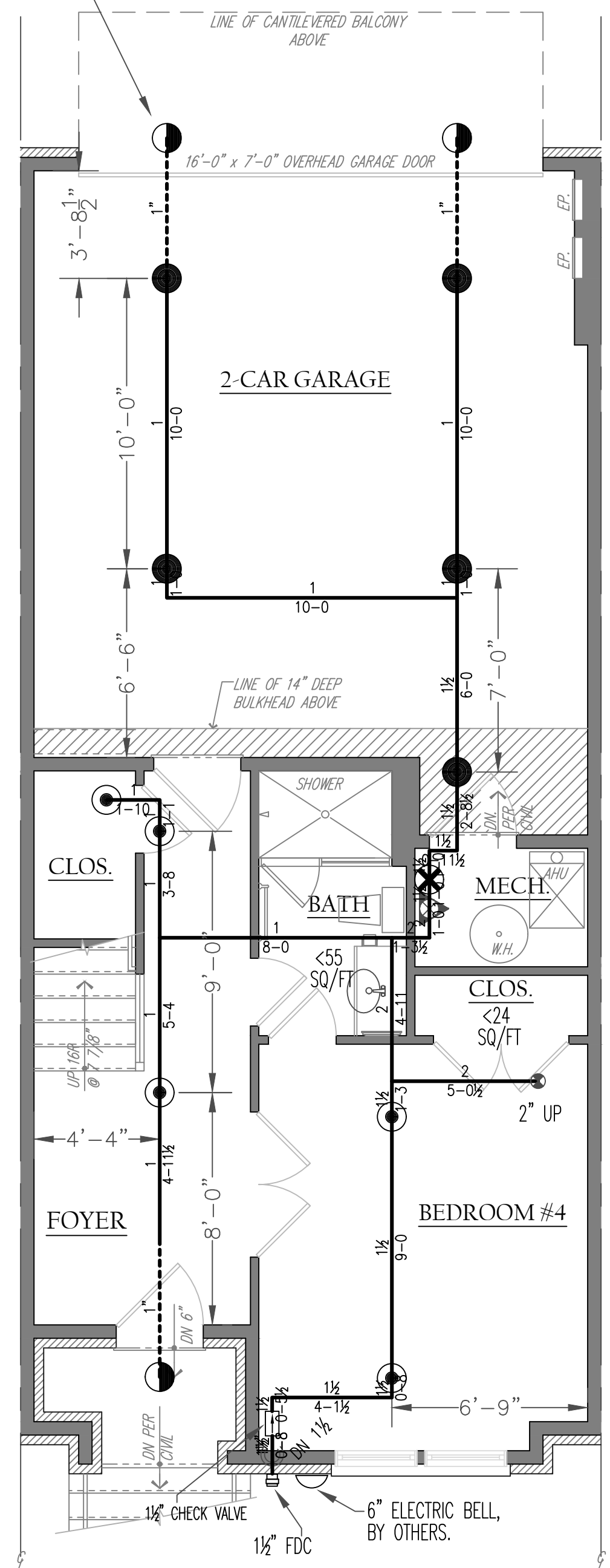

GROUND FLOOR PLAN

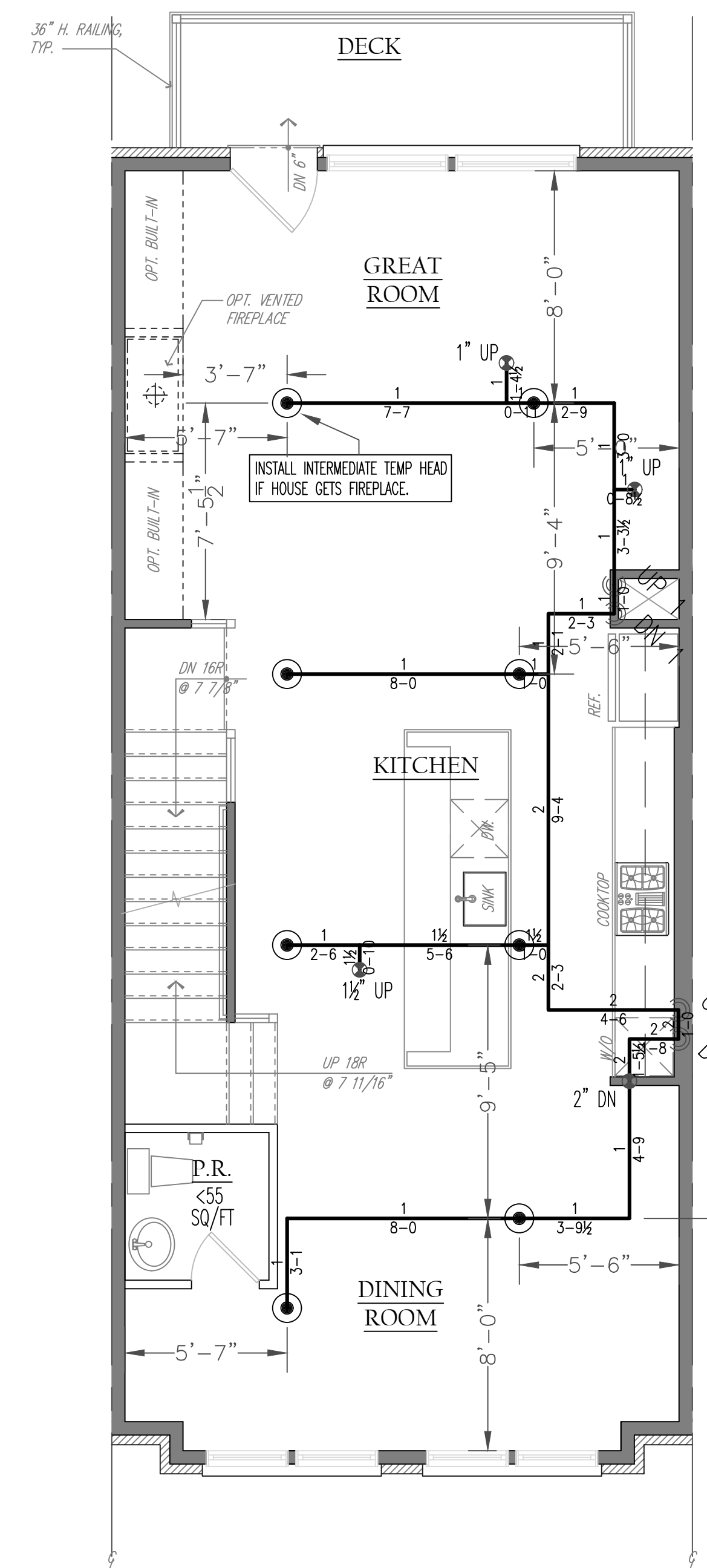

SECOND FLOOR PLAN

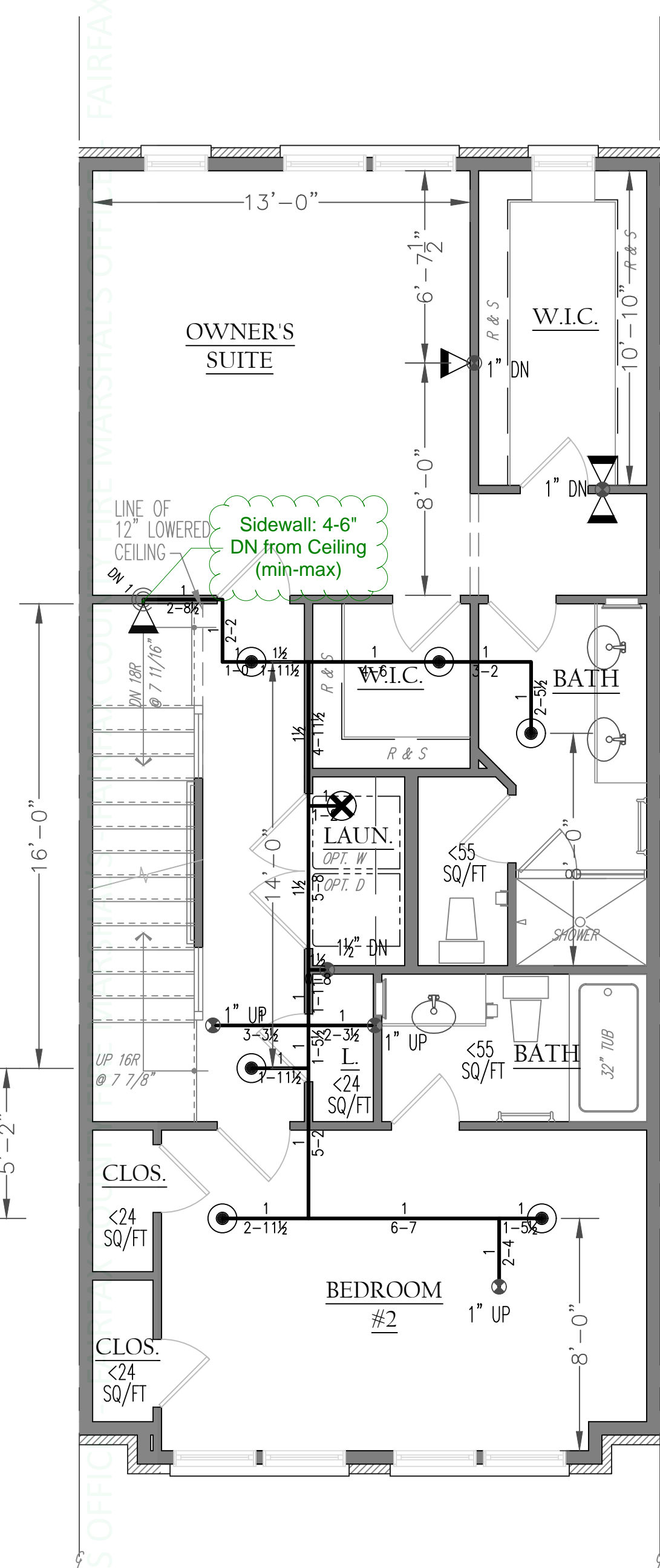

THIRD FLOOR PLAN

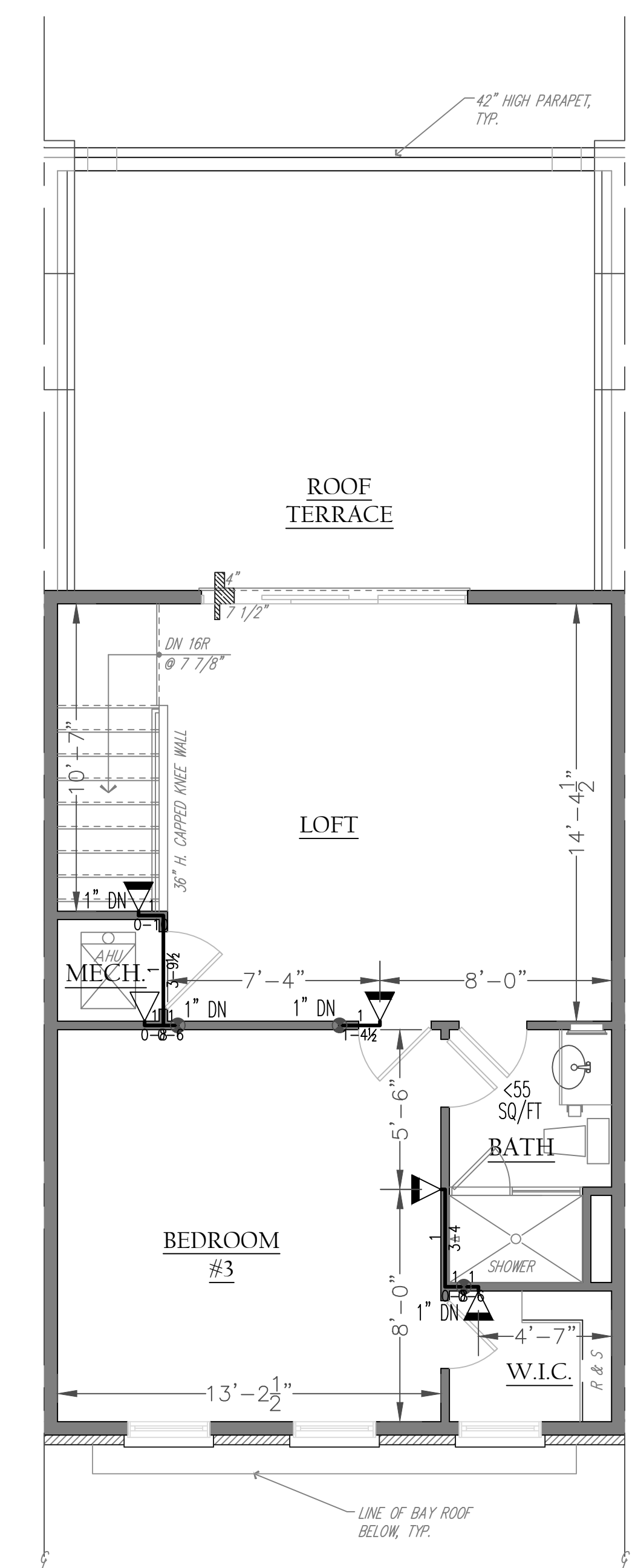

LOFT FLOOR PLAN

**GENERAL NOTE**  
Sprinklers are not required when multiple bathrooms are adjacent to each other and are considered separate rooms, provided they contain a lintel of a minimum of 8" and they are dedicated to personal hygiene, or a water closet, or bathing capability such as a shower or tub, or any combination of facilities thereof. NFPA #13R, 2016 was used as a future reference guide for clarification.

**CEILING HEIGHTS (UNLESS NOTED OTHERWISE)**  
1ST FLOOR - 9'-1 1/8"  
2ND FLOOR - 10'-1 1/8"  
3RD FLOOR - 9'-1 1/8"  
4TH FLOOR - 9'-1 1/8"

**MAXIMUM SPACING OF ALL RESIDENTIAL SPRINKLERS**  
PENDENT HEADS: 16' X 16' AND 8' FROM WALL, W/ DEFLECTOR 1" TO 4" FROM CEILING  
SIDEWALL HEADS: 16' X 16' AND 8' FROM WALL, W/ DEFLECTOR 4" TO 6" FROM CEILING  
DRY PENDENT HEADS: 14' X 14' AND 7' FROM WALL, W/ DEFLECTOR 1" TO 4" FROM CEILING  
FLEX DRY PENDENT HEADS: 14' X 14' AND 7' FROM WALL, W/ DEFLECTOR 1" TO 4" FROM CEILING

SPRINKLERS		DESIGN CRITERIA		SPECIALTY ITEMS		SYMBOLS		ABBREVIATIONS		PLAN REVISIONS	
SYMBOL	MANUF./MODEL	TEMP.	FINISH	TOTAL	NFPA REF.	FLR	TYPE	TYPE	TYPE	DATE	DESCRIPTION
○	1/2" REG. PEND.	155 DEG	WHITE	19		FLR	TYPE	TYPE	TYPE		
○	3/4" REG. PEND.	155 DEG	WHITE	2		FLR	TYPE	TYPE	TYPE		
○	1/2" REG. SIDEWALL	155 DEG	WHITE	8		FLR	TYPE	TYPE	TYPE		
○	3/4" REG. SIDEWALL	155 DEG	WHITE	1		FLR	TYPE	TYPE	TYPE		
○	1/2" FLEX DRY PEND.	155 DEG	WHITE	5		FLR	TYPE	TYPE	TYPE		
○	3/4" FLEX DRY PEND.	155 DEG	WHITE	3		FLR	TYPE	TYPE	TYPE		
JOB TOTAL				38							
TOTAL THIS SHEET				38							
JOB TOTAL				38							
				38							

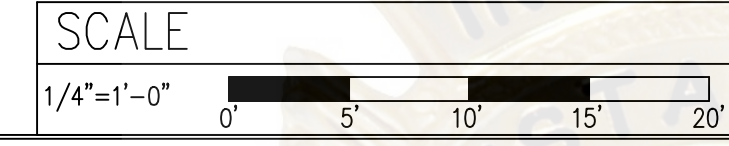

JOB NAME: FARADAY PARK  
1878 EASTERLY RD.  
RESTON, VA. 20190

DATE: 6-25-2020  
SCALE: 1/4"=1'-0"  
CONTRACT NO: 20-0073  
APPROVALS: FAIRFAX COUNTY F.M.O.  
DRAWN BY: CMS  
REVIEWED BY: CONTRACTOR:  
AREA: LOT 7  
CAD FILE: FARADAYSUBMIT  
PERMIT NO: 200570028  
CONTRACTOR PHONE: 703-996-4246

DRAWING NO: 5 OF 8

**BUILDERS FIRE SOLUTIONS**  
225 ELM STREET, WARRENTON, VA 20186 (540) 428-8712  
AUTOMATIC FIRE PROTECTION SYSTEMS  
DESIGN INSTALLATION SERVICE







NOTE: This sheet for sprinkler reference only.

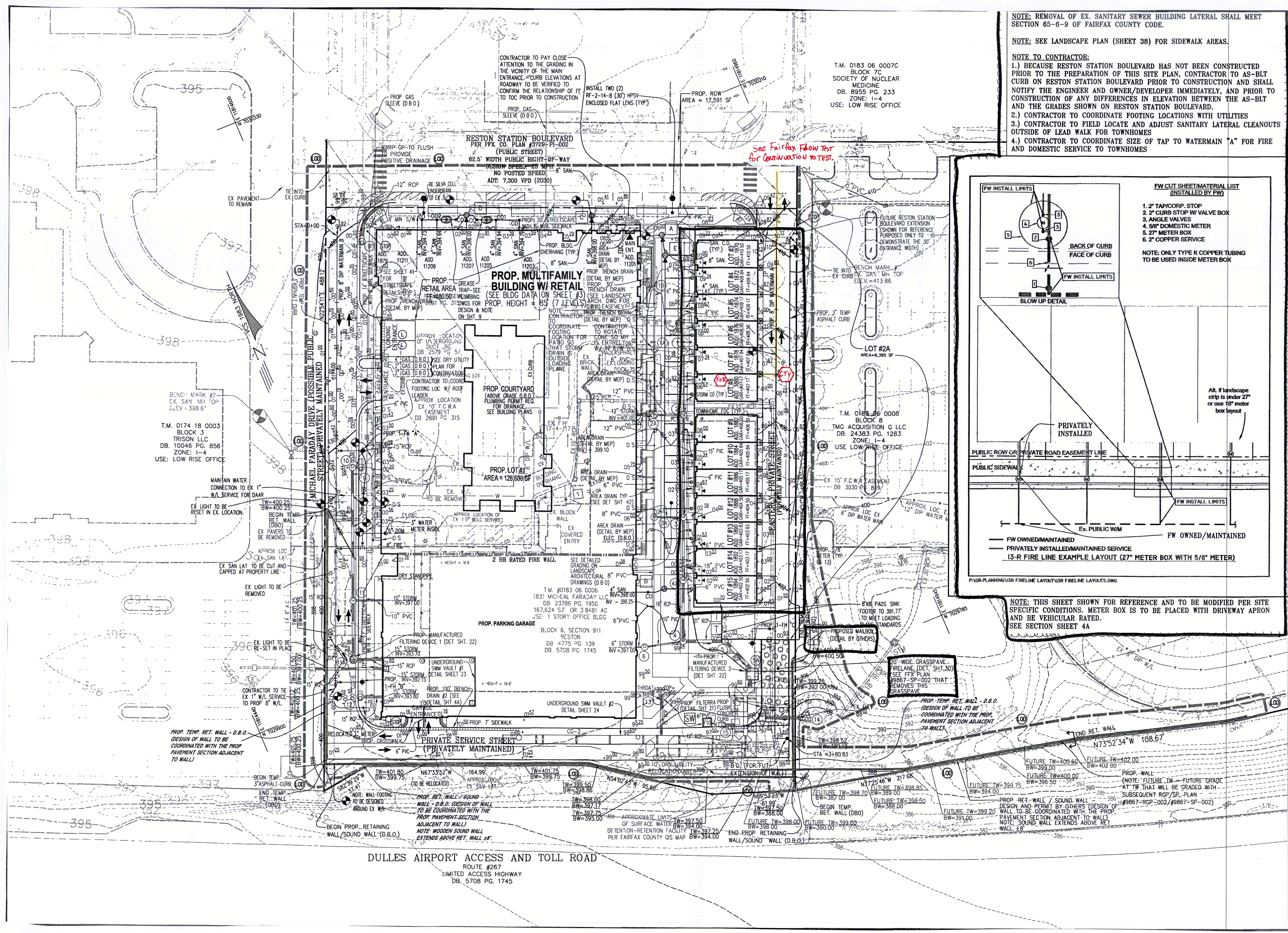

NOTE: REMOVAL OF EX. SANITARY SEWER BUILDING LATERAL SHALL MEET SECTION 65-6-9 OF FAIRFAX COUNTY CODE.

NOTE: SEE LANDSCAPE PLAN (SHEET 38) FOR SIDEWALK AREAS.

NOTE TO CONTRACTOR:  
1.) BECAUSE RESTON STATION BOULEVARD HAS NOT BEEN CONSTRUCTED PRIOR TO THE PREPARATION OF THIS SITE PLAN, CONTRACTOR TO AS-BLT CURB ON RESTON STATION BOULEVARD PRIOR TO CONSTRUCTION AND SHALL NOTIFY THE ENGINEER AND OWNER/DEVELOPER IMMEDIATELY, AND PRIOR TO CONSTRUCTION OF ANY DIFFERENCES IN ELEVATION BETWEEN THE AS-BLT AND THE GRADES SHOWN ON RESTON STATION BOULEVARD.  
2.) CONTRACTOR TO COORDINATE FOOTING LOCATIONS WITH UTILITIES  
3.) CONTRACTOR TO FIELD LOCATE AND ADJUST SANITARY LATERAL CLEANOUTS OUTSIDE OF LEAD WALK FOR TOWNHOMES  
4.) CONTRACTOR TO COORDINATE SIZE OF TAP TO WATERMAIN "A" FOR FIRE AND DOMESTIC SERVICE TO TOWNHOMES

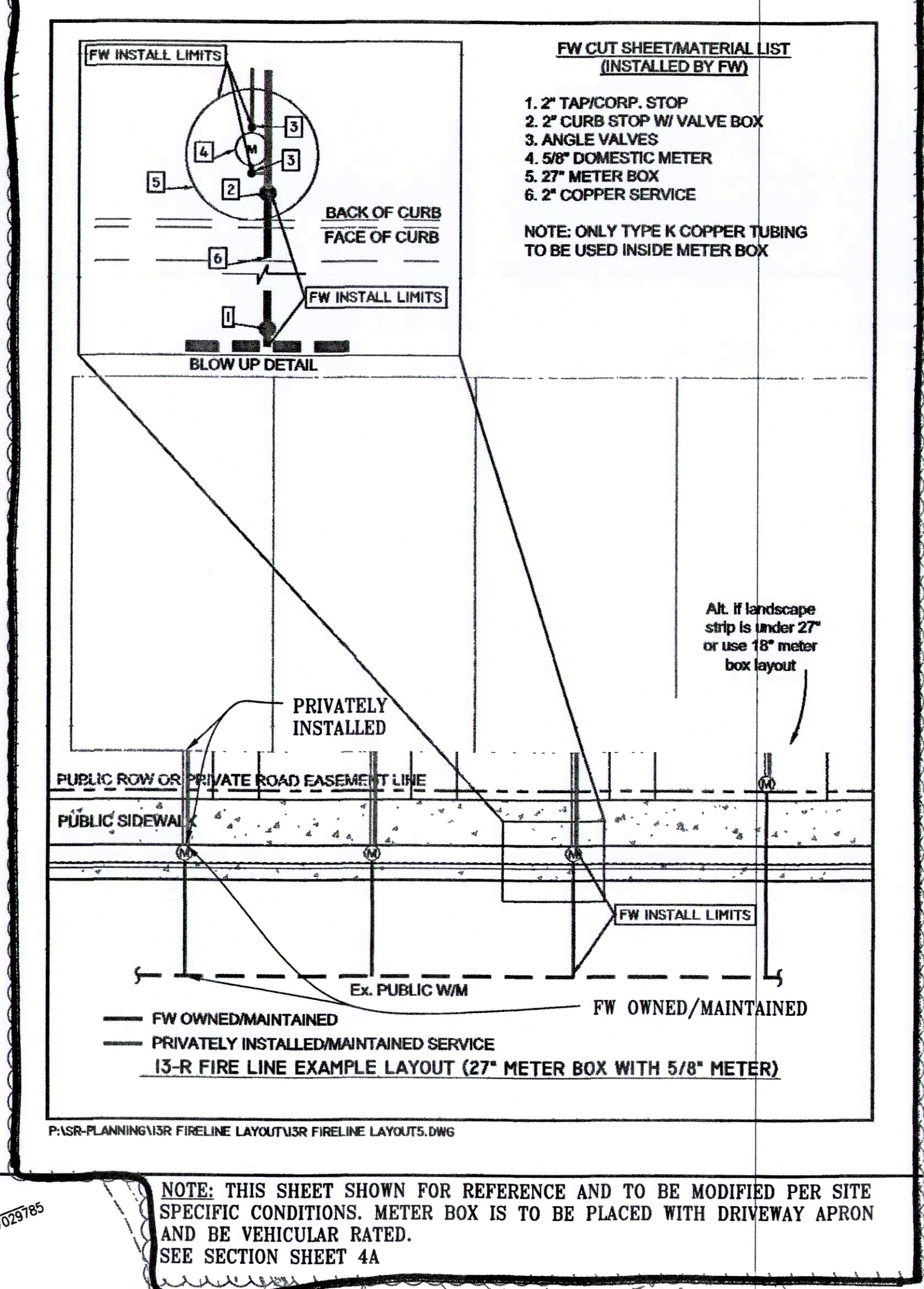

NOTE: THIS SHEET SHOWN FOR REFERENCE AND TO BE MODIFIED PER SITE SPECIFIC CONDITIONS. METER BOX IS TO BE PLACED WITH DRIVEWAY APRON AND BE VEHICULAR RATED. SEE SECTION SHEET 4A

REVISION	DATE	DESCRIPTION	BY	APPROVED
1	07-15-20	REVISED PER PERMITS		
2	07-15-20	REVISED PER PERMITS		
3	07-15-20	REVISED PER PERMITS		
4	07-15-20	REVISED PER PERMITS		
5	07-15-20	REVISED PER PERMITS		
6	07-15-20	REVISED PER PERMITS		
7	07-15-20	REVISED PER PERMITS		
8	07-15-20	REVISED PER PERMITS		
9	07-15-20	REVISED PER PERMITS		
10	07-15-20	REVISED PER PERMITS		

GRADING PLAN  
RESTON SECTION 911, BLOCK 6  
REDEVELOPMENT  
HUNTER MILL DISTRICT  
FAIRFAX COUNTY, VIRGINIA

DATE: OCT, 2017  
SCALE: 1"=30'

SHEET 7 OF 49  
FILE No. SP-2217

JOB NAME: FARADAY PARK  
1870-1880 EASTERLY RD.  
RESTON, VA. 20190

DATE: 6-25-2020  
SCALE: AS NOTED  
PLAN NORTH: CMS

CONTRACT NO: 20-0073  
REVIEWED BY: KNOTSON COMPANIES

APPROVALS: FAIRFAX COUNTY F.M.O.  
CONTRACTOR: KNOTSON COMPANIES

AS NOTED  
SITE PLAN: LOTS 3-8  
PERMIT NO: 703-996-4246  
SEE SHEETS 1-6

DRWG NO: 8  
OF 8

**BUILDERS FIRE SOLUTIONS**  
225 ELM STREET, WARRENTON, VA 20186 (540) 428-8712  
AUTOMATIC FIRE PROTECTION SYSTEMS  
DESIGN INSTALLATION SERVICE



## TECHNICAL DATA

## FREEDOM® RESIDENTIAL PENDENT SPRINKLER VK468 (K4.9)

The Viking Corporation, 210 N Industrial Park Drive, Hastings MI 49058

Telephone: 269-945-9501 Technical Services: 877-384-5464 Fax: 269-818-1680 Email: techsvcs@vikingcorp.com

Visit the Viking website for the latest edition of this technical data page [www.vikinggroupinc.com](http://www.vikinggroupinc.com)

### 1. DESCRIPTION

Viking Freedom® Residential Pendent Sprinkler VK468 is a small, thermosensitive, glass-bulb residential sprinkler available in several different finishes and temperature ratings to meet varying design requirements. The Electroless Nickel PTFE (ENT) coating has been investigated for installation in corrosive atmospheres and is C-UL-US-EU Listed as corrosion resistant as indicated in the Approval Chart. The orifice design, with a K-Factor of 4.9 (70.6 metric†), allows efficient use of available water supplies for the hydraulically designed fire-protection system. The glass bulb operating element and special deflector characteristics meet the challenges of residential sprinkler standards.

### 2. LISTINGS AND APPROVALS



**UL Listed (C-UL-US-EU):** Category VKKW



**VdS Approved**

**NYC Approved:** MEA 89-92-E, Volume 35

**UL Classified to:** NSF/ANSI Standard 61, Drinking Water System Components (MH48034).

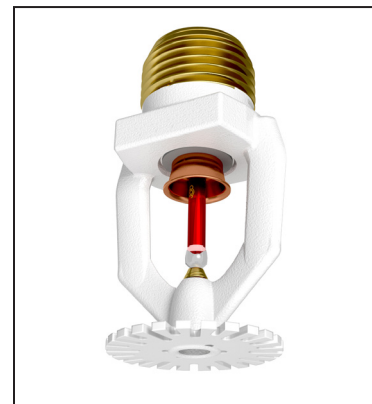

**WARNING:** Cancer and Reproductive Harm-  
[www.P65Warnings.ca.gov](http://www.P65Warnings.ca.gov)

Refer to the Approval Chart and Design Criteria for C-UL-US-EU Listing requirements that must be followed.

### 3. TECHNICAL DATA

#### Specifications:

Available since 2006.

Minimum Operating Pressure: Refer to the Approval Chart.

Maximum Working Pressure: 175 psi (12 bar). Factory tested hydrostatically to 500 psi (34.5 bar).

Thread size: 1/2" (15 mm) NPT

Nominal K-Factor: 4.9 U.S. (70.6 metric†)

†Metric K-factor measurement shown is in Bar. When pressure is measured in kPa, divide the metric K-factor shown by 10.0.

Glass-bulb fluid temperature rated to -65 °F (-55 °C)

Overall Length: 2-1/4" (58 mm)

#### Material Standards:

Frame Casting: Brass UNS-C84400 or QM Brass

Deflector: Brass UNS-C23000, Phosphor Bronze UNS-C51000, or Brass UNS-C26000

Bulb: Glass, nominal 3 mm diameter

Belleville Spring Sealing Assembly: Nickel Alloy, coated on both sides with Polytetrafluoroethylene (PTFE) Tape

Pip Cap and Insert Assembly: Copper UNS-C11000 and Stainless Steel UNS-S30400

Compression Screw: Brass UNS-C36000

For ENT coated sprinklers: Belleville spring - Exposed. Screw and Pipcap - ENT plated.

**Ordering Information:** (Also refer to the current Viking price list.)

**Sprinkler:** Base Part No. 13637

Order Sprinkler VK468 by first adding the appropriate suffix for the sprinkler finish and then the appropriate suffix for the temperature rating to the sprinkler base part number.

Finish Suffix: Brass = A, Chrome = F, White Polyester = M-/W, Black Polyester = M-/B, and ENT = JN

Temperature Suffix: 155 °F (68 °C) = B, 175 °F (79 °C) = D

For example, sprinkler VK468 with a Brass finish and a 155 °F (68 °C) temperature rating = Part No. 13637AB.

#### Available Finishes And Temperature Ratings:

Refer to Table 1.

**Accessories:** (Also refer to the Viking website.)

#### Sprinkler Wrenches:

A. Standard Wrench: Part No. 21475M/B (available since 2017)

B. Wrench for recessed sprinklers: Part No. 13577W/B\* (available since 2006)

C. Optional Protective Sprinkler Cap Remover/Escutcheon Installer Tool\*\* Part No. 15915 (available since 2010.)

\*A 1/2" ratchet is required (not available from Viking).

\*\*Allows use from the floor by attaching a length of 1" diameter CPVC tubing to the tool. Ideal for sprinkler cabinets. Refer to Bulletin F\_051808.

	<b>TECHNICAL DATA</b>	<b>FREEDOM® RESIDENTIAL PENDENT SPRINKLER VK468 (K4.9)</b>
---	-----------------------	--

**The Viking Corporation, 210 N Industrial Park Drive, Hastings MI 49058**  
**Telephone: 269-945-9501 Technical Services: 877-384-5464 Fax: 269-818-1680 Email: techsvcs@vikingcorp.com**  
**Visit the Viking website for the latest edition of this technical data page [www.vikinggroupinc.com](http://www.vikinggroupinc.com)**

**Sprinkler Cabinets:**

- A. Six-head capacity: Part No. 01724A (available since 1971)
- B. Twelve-head capacity: Part No. 01725A (available since 1971)

**4. INSTALLATION**

Refer to appropriate NFPA Installation Standards.

**5. OPERATION**

During fire conditions, the heat-sensitive liquid in the glass bulb expands, causing the glass to shatter, releasing the pip cap and sealing spring assembly. Water flowing through the sprinkler orifice strikes the sprinkler deflector, forming a uniform spray pattern to extinguish or control the fire.

**6. INSPECTIONS, TESTS AND MAINTENANCE**

Refer to NFPA 25 for Inspection, Testing and Maintenance requirements.

**7. AVAILABILITY**

The Viking Model VK468 Sprinkler is available through a network of domestic and international distributors. See The Viking Corporation web site for the closest distributor or contact The Viking Corporation.

**8. GUARANTEE**

For details of warranty, refer to Viking's current list price schedule or contact Viking directly.

**TABLE 1: AVAILABLE SPRINKLER TEMPERATURE RATINGS AND FINISHES**

Sprinkler Temperature Classification	Sprinkler Nominal Temperature Rating <sup>1</sup>	Maximum Ambient Ceiling Temperature <sup>2</sup>	Bulb Color
Ordinary	155 °F (68 °C)	100 °F (38 °C)	Red
Intermediate	175 °F (79 °C)	150 °F (65 °C)	Yellow

**Sprinkler Finishes:** Brass, Chrome, White Polyester, Black Polyester, and ENT

**Corrosion Resistant Coatings<sup>3</sup>:** ENT

**Footnotes**

- <sup>1</sup> The sprinkler temperature rating is stamped on the deflector.
- <sup>2</sup> Based on NFPA-13. Other limits may apply, depending on fire loading, sprinkler location, and other requirements of the Authority Having Jurisdiction. Refer to specific installation standards.
- <sup>3</sup> The corrosion resistant coatings have passed the standard corrosion test required by the approving agencies indicated in the Approval Chart. These tests cannot and do not represent all possible corrosive environments. Prior to installation, verify through the end-user that the coatings are compatible with or suitable for the proposed environment. For ENT coated sprinklers, the waterway is coated. Note that the spring is exposed on sprinklers with ENT coating.

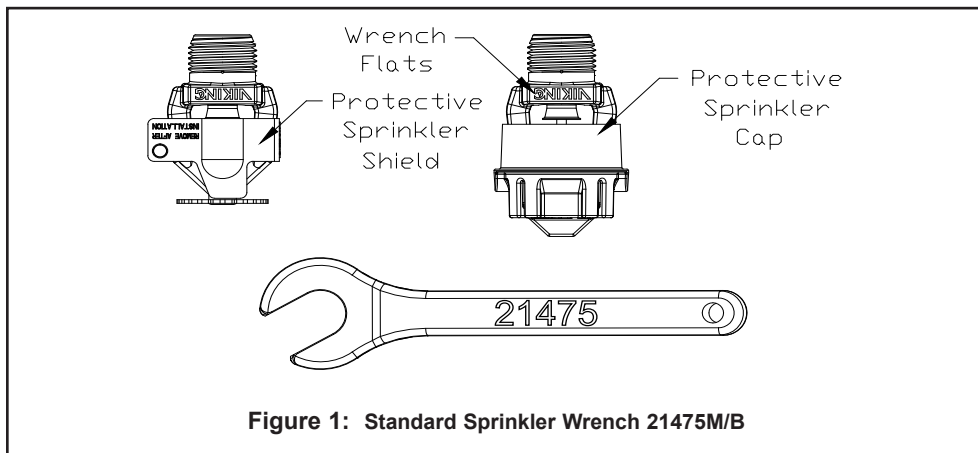

**Figure 1: Standard Sprinkler Wrench 21475M/B**



## TECHNICAL DATA

## FREEDOM® RESIDENTIAL PENDENT SPRINKLER VK468 (K4.9)

The Viking Corporation, 210 N Industrial Park Drive, Hastings MI 49058

Telephone: 269-945-9501 Technical Services: 877-384-5464 Fax: 269-818-1680 Email: techsvcs@vikingcorp.com

Visit the Viking website for the latest edition of this technical data page [www.vikinggroupinc.com](http://www.vikinggroupinc.com)

### Approval Chart

### Viking VK468, 4.9 K-Factor Residential Pendent Sprinkler

For systems designed to NFPA 13D or NFPA 13R. For systems designed to NFPA 13, refer to the design criteria. For Ceiling types refer to current editions of NFPA 13, 13R or 13D

Sprinkler Base Part Number <sup>1</sup>	SIN	NPT Thread Size		Nominal K-Factor		Maximum Water Working Pressure	Overall Length				
		Inches	mm	U.S.	metric <sup>2</sup>		Inches	mm			
13637	VK468	1/2	15	4.9	70.6	175 psi (12 bar)	2-1/4	58			
Max. Coverage Area <sup>4</sup> Ft.X Ft. (m X m)	Ordinary Temp Rating (155 °F/68 °C)		Intermediate Temp Rating (175 °F/79 °C)		Deflector to Ceiling	Installation Type	Listings and Approvals <sup>3</sup>				Minimum Spacing Ft. (m)
	Flow <sup>4</sup> GPM (L/min)	Pressure <sup>4</sup> PSI (bar)	Flow <sup>4</sup> GPM (L/min)	Pressure <sup>4</sup> PSI (bar)			C-UL-US-EU <sup>5</sup>	VdS	NYC <sup>6</sup>	NSF <sup>8</sup>	
12 X 12 (3.7 X 3.7)	13 (49.2)	7.0 (0.48)	13 (49.2)	7.0 (0.48)	1-1/8 to 2 inch	Standard surface-mounted escutcheons, or recessed with the Micromatic® Model E-1, E-2, or E-3 Recessed Escutcheon	See Foot-notes 7 and 10.	See Foot-notes 7 and 10.	See Foot-note 7.	See Foot-note 7.	8 (2.4)
14 X 14 (4.3 X 4.3)	13 (49.2)	7.0 (0.48)	13 (49.2)	7.0 (0.48)							
16 X 16 (4.9 X 4.9)	13 (49.2)	7.0 (0.48)	13 (49.2)	7.0 (0.48)							
18 X 18 (5.5 X 5.5)	17 (64.4)	12.0 (0.83)	17 (64.4)	12.0 (0.83)							
20 X 20 (6.1 X 6.1)	20 (75.7)	16.7 (1.15)	20 (75.7)	16.7 (1.15)							

#### Footnotes

<sup>1</sup> Part number shown is the base part number. For complete part number, refer to Viking's current price schedule.

<sup>2</sup> Metric K-factor measurement shown is when pressure is measured in Bar. When pressure is measured in kPa, divide the metric K-factor shown by 10.0.

<sup>3</sup> This chart shows the listings and approvals available at the time of printing. Other approvals may be in process. Check with the manufacturer for any additional approvals. Refer also to Design Criteria.

<sup>4</sup> For areas of coverage smaller than shown, use the "Flow" and "Pressure" for the next larger area listed. Flows and pressures listed are per sprinkler. The distance from sprinklers to walls shall not exceed one-half the sprinkler spacing indicated for the minimum "Flow" and "Pressure" used.

<sup>5</sup> Listed by Underwriter's Laboratories, Inc. for use in the U.S., Canada, and European Union.

<sup>6</sup> Accepted for use, City of New York Department of Buildings, MEA Number 89-92-E, Vol. 35.

<sup>7</sup> Approved Finishes are: Brass, Chrome, White Polyester, and Black Polyester<sup>9</sup>

<sup>8</sup> UL Classified to: NSF/ANSI Standard 61, Drinking Water System Components (MH48034).

<sup>9</sup> Other paint colors are available on request with the same C-UL-US-EU listings as the standard finish colors.

<sup>10</sup> Approved finish is Electroless Nickel PTFE (ENT). ENT is C-UL-US-EU Listed as corrosion resistant. ENT is available with standard surface-mounted escutcheons or the Micromatic Model E-1 Recessed Escutcheon.



**TECHNICAL DATA**

**FREEDOM® RESIDENTIAL  
PENDENT SPRINKLER  
VK468 (K4.9)**

The Viking Corporation, 210 N Industrial Park Drive, Hastings MI 49058  
 Telephone: 269-945-9501 Technical Services: 877-384-5464 Fax: 269-818-1680 Email: techsvcs@vikingcorp.com  
 Visit the Viking website for the latest edition of this technical data page www.vikinggroupinc.com

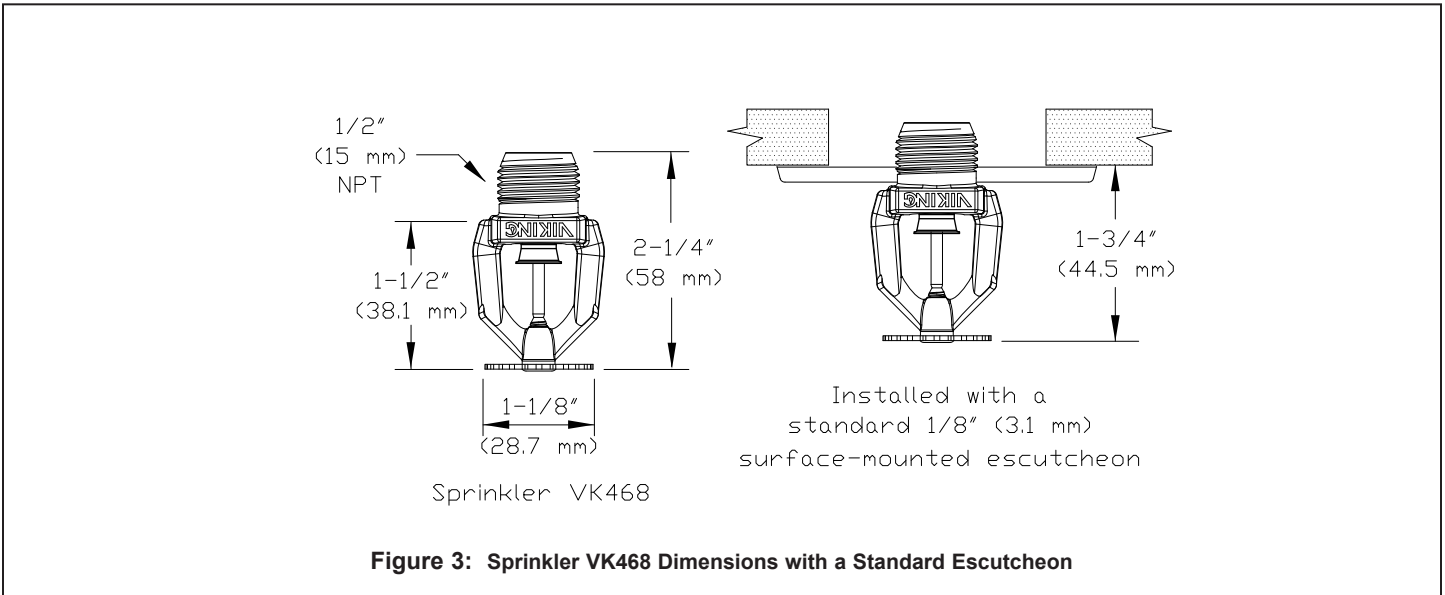
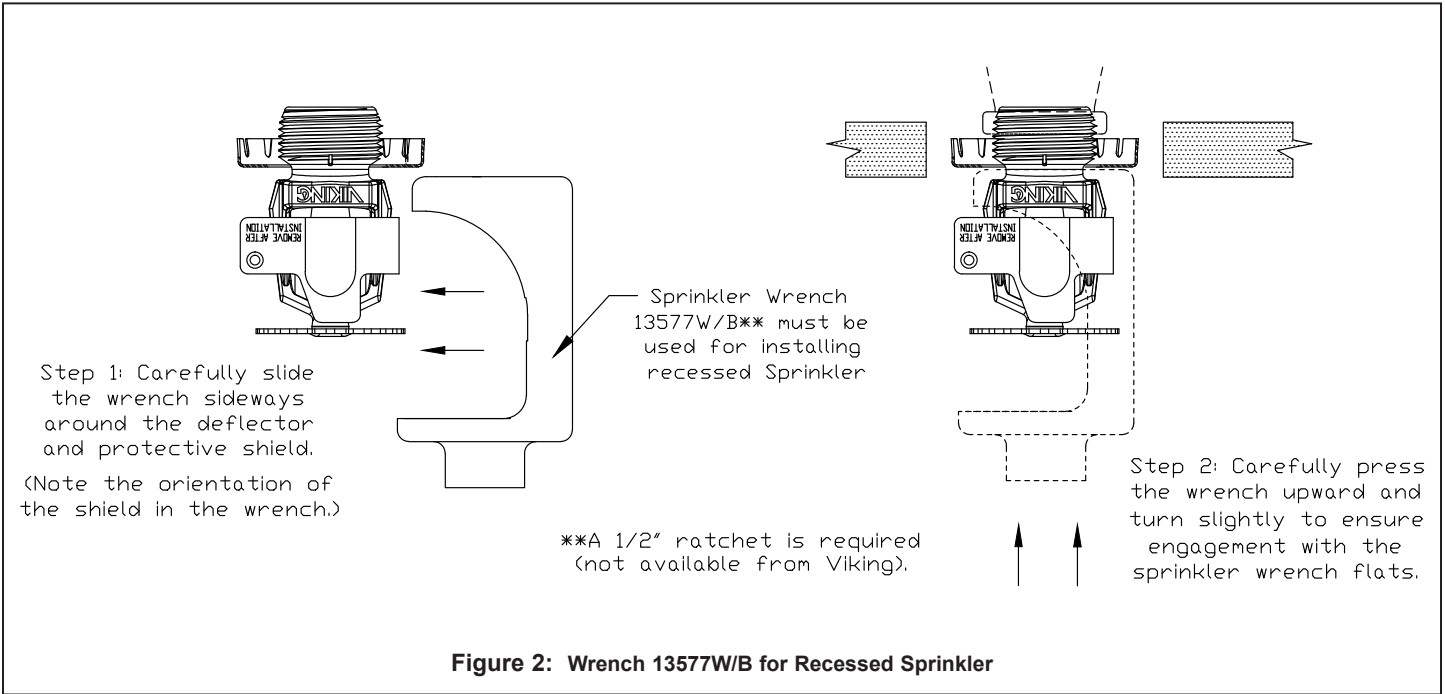



## TECHNICAL DATA

## FREEDOM® RESIDENTIAL PENDENT SPRINKLER VK468 (K4.9)

The Viking Corporation, 210 N Industrial Park Drive, Hastings MI 49058

Telephone: 269-945-9501 Technical Services: 877-384-5464 Fax: 269-818-1680 Email: techsvcs@vikingcorp.com

Visit the Viking website for the latest edition of this technical data page [www.vikinggroupinc.com](http://www.vikinggroupinc.com)

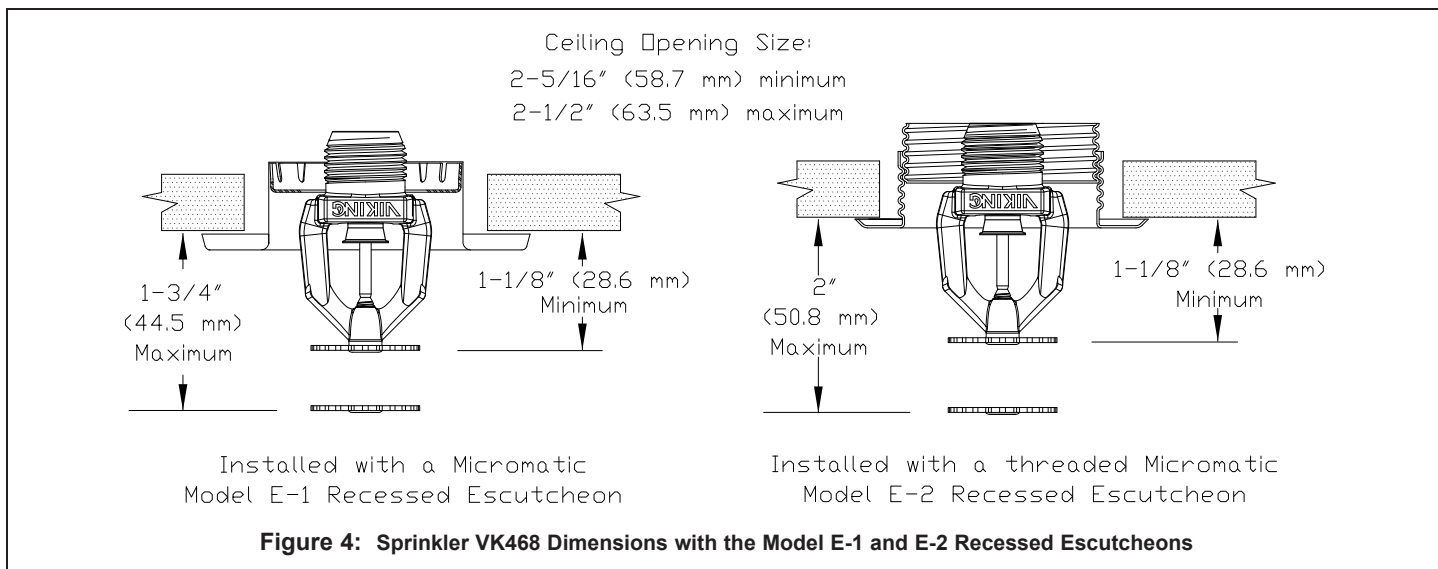

### DESIGN CRITERIA

(Also refer to the Approval Chart.)

#### UL Listing Requirements (C-UL-US-EU):

When using Viking Residential Pendant Sprinkler VK468 for systems designed to NFPA 13D or NFPA 13R, apply the listed areas of coverage and minimum water supply requirements shown in the Approval Chart.

For systems designed to NFPA 13: The number of design sprinklers is to be the four contiguous most hydraulically demanding sprinklers. The minimum required discharge from each of the four sprinklers is to be the greater of the following:

- The flow rates given in the Approval Chart for NFPA 13D and NFPA13R applications for each listed area of coverage, **or**
- Calculated based on a minimum discharge of 0.1 gpm/sq. ft. over the "design area" in accordance with sections 8.5.2.1 or 8.6.2.1.2 of NFPA 13.
- Minimum distance between residential sprinklers: 8 ft. (2.4 m).

**IMPORTANT: Always refer to Bulletin Form No. F\_091699 - Care and Handling of Sprinklers. Also refer to Form No. F\_080614, F\_080415 and F\_080190 for general care, installation, and maintenance information. Viking sprinklers are to be installed in accordance with the latest edition of Viking technical data, the appropriate standards of NFPA, VdS, and any other similar Authorities Having Jurisdiction, and also with the provisions of governmental codes, ordinances, and standards, whenever applicable. Final approval and acceptance of all residential sprinkler installations must be obtained from the Authorities Having Jurisdiction.**





## TECHNICAL DATA

## FREEDOM® RESIDENTIAL HORIZONTAL SIDEWALL SPRINKLER VK486 (K4.0)

The Viking Corporation, 210 N Industrial Park Drive, Hastings MI 49058

Telephone: 269-945-9501 Technical Services: 877-384-5464 Fax: 269-818-1680 Email: techsvcs@vikingcorp.com

Visit the Viking website for the latest edition of this technical data page: [www.vikinggroupinc.com](http://www.vikinggroupinc.com)

### 1. DESCRIPTION

Viking Freedom® Residential Horizontal Sidewall Sprinkler VK486 is a small, thermostatic, glass-bulb residential sprinkler available in several different finishes and temperature ratings to meet varying design requirements. The Electroless Nickel PTFE (ENT) coating has been investigated for installation in corrosive atmospheres and is C-UL-US-EU Listed as corrosion resistant as indicated in the Approval Chart. The sprinkler orifice design, with a K-Factor of 4.0 (57.7 metric†), allows efficient use of available water supplies for the hydraulically designed fire-protection system. The glass bulb operating element and special deflector characteristics meet the challenges of residential sprinkler standards.

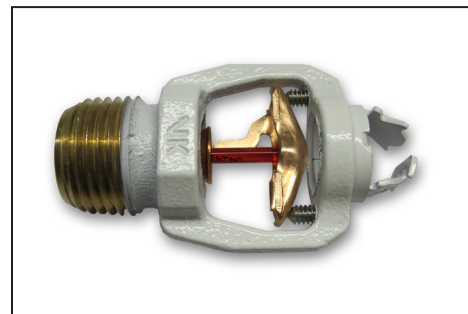

### 2. LISTINGS AND APPROVALS

 **UL Listed (C-UL-US-EU):** Category VKKW

 **VdS Approved**

 **WARNING:** Cancer and Reproductive Harm-  
[www.P65Warnings.ca.gov](http://www.P65Warnings.ca.gov)

Refer to the Approval Chart and Design Criteria for C-UL-US-EU Listing requirements that must be followed.

### 3. TECHNICAL DATA

#### Specifications:

Available since 2011.

Minimum Operating Pressure: Refer to the Approval Chart.

Maximum Working Pressure: 175 psi (12 bar). Factory tested hydrostatically to 500 psi (34.5 bar).

Thread size: 1/2" (15 mm) NPT

Nominal K-Factor: 4.0 U.S. (57.7 metric†)

† Metric K-factor measurement shown is in Bar. When pressure is measured in kPa, divide the metric K-factor shown by 10.0.

Glass-bulb fluid temperature rated to -65 °F (-55 °C)

Overall Length: 2-7/16" (62 mm)

Covered by the following US Patent numbers: 7,854,269 and 7,712,218

#### Material Standards:

Frame Casting: QM Brass and Brass UNS-C84400

Deflector: Phosphor Bronze UNS-C51000

Bulb: Glass, nominal 3 mm diameter

Belleville Spring Sealing Assembly: Nickel Alloy, coated on both sides with PTFE Tape

Pip Cap and Insert Assembly: Copper UNS-C11000 and Stainless Steel UNS-S30400

Compression Screws: 18-8 Stainless Steel

Yoke: Phosphor Bronze UNS-C51000

**Ordering Information:** (Also refer to the current Viking price list.)

**Sprinkler:** Base Part No. 17315

Order Sprinkler VK486 by first adding the appropriate suffix for the sprinkler finish and then the appropriate suffix for the temperature rating to the sprinkler base part number.

Finish Suffix: Brass = A, Chrome = F, White Polyester = M-/W, Black Polyester = M-/B

Temperature Suffix: 155 °F (68 °C) = B, 175 °F (79 °C) = D

For example, sprinkler VK486 with a Brass finish and a 155 °F (68 °C) temperature rating = Part No. 17315AB.

#### Available Finishes And Temperature Ratings:

Refer to Table 1.

**Accessories:** (Also refer to the Viking website.)

#### Sprinkler Wrenches:

A. Standard Wrench: Part No. 21475M/B (available since 2017)

B. Wrench for recessed sprinklers: Part No. 13655W/B\* (available since 2006)

\*A 1/2" ratchet is required (not available from Viking).



**TECHNICAL DATA**

**FREEDOM® RESIDENTIAL HORIZONTAL SIDEWALL SPRINKLER VK486 (K4.0)**

The Viking Corporation, 210 N Industrial Park Drive, Hastings MI 49058  
 Telephone: 269-945-9501 Technical Services: 877-384-5464 Fax: 269-818-1680 Email: techsvcs@vikingcorp.com  
 Visit the Viking website for the latest edition of this technical data page: www.vikinggroupinc.com

**Sprinkler Cabinets:**

- A. Six-head capacity: Part No. 01724A (available since 1971)
- B. Twelve-head capacity: Part No. 01725A (available since 1971)

**4. INSTALLATION**

Refer to appropriate NFPA Installation Standards.

**5. OPERATION**

During fire conditions, the heat-sensitive liquid in the glass bulb expands, causing the glass to shatter, releasing the yoke, pip cap, and sealing spring assembly. Water flowing through the sprinkler orifice strikes the sprinkler deflector, forming a uniform spray pattern to extinguish or control the fire.

**6. INSPECTIONS, TESTS AND MAINTENANCE**

Refer to NFPA 25 for Inspection, Testing and Maintenance requirements.

**7. AVAILABILITY**

Viking Sprinkler VK486 is available through a network of domestic and international distributors. See The Viking Corporation web site for the closest distributor or contact The Viking Corporation.

**8. GUARANTEE**

For details of warranty, refer to Viking's current list price schedule or contact Viking directly.

**TABLE 1: AVAILABLE SPRINKLER TEMPERATURE RATINGS AND FINISHES**

Sprinkler Temperature Classification	Sprinkler Nominal Temperature Rating <sup>1</sup>	Maximum Ambient Ceiling Temperature <sup>2</sup>	Bulb Color
Ordinary	155 °F (68 °C)	100 °F (38 °C)	Red
Intermediate	175 °F (79 °C)	150 °F (65 °C)	Yellow

**Sprinkler Finishes:** Brass, Chrome, White Polyester, and Black Polyester.

**Footnotes**

<sup>1</sup> The sprinkler temperature rating is stamped on the deflector.

<sup>2</sup> Based on NFPA-13. Other limits may apply, depending on fire loading, sprinkler location, and other requirements of the Authority Having Jurisdiction. Refer to specific installation standards.

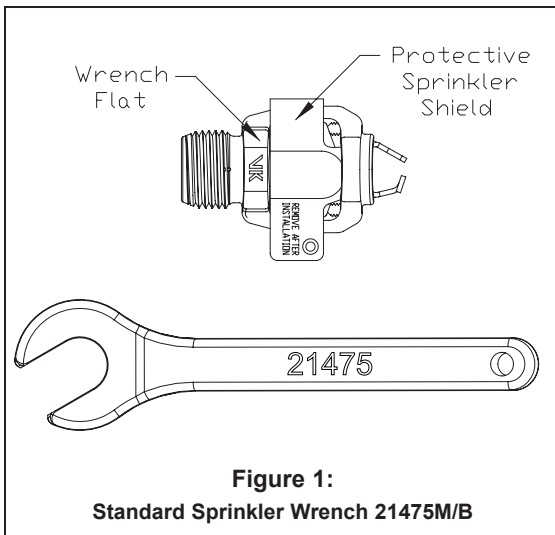

**Figure 1:**  
Standard Sprinkler Wrench 21475M/B

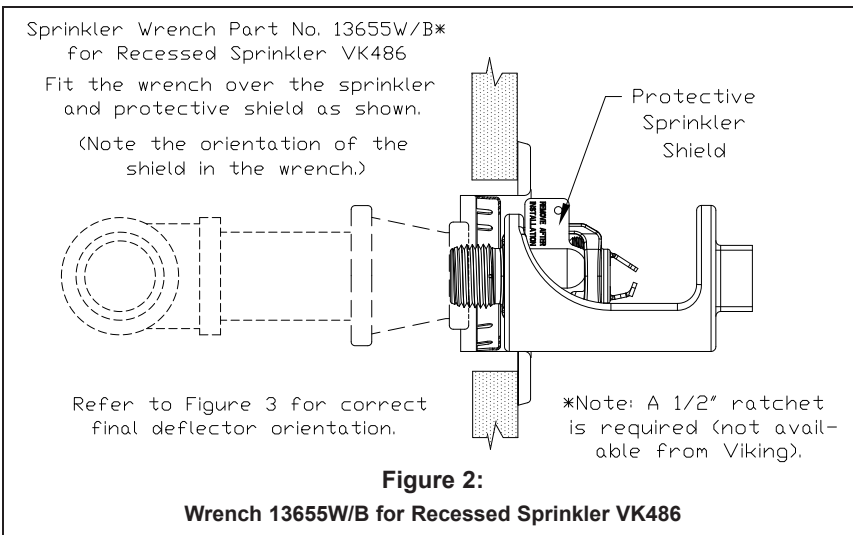

**Figure 2:**  
Wrench 13655W/B for Recessed Sprinkler VK486



## TECHNICAL DATA

## FREEDOM® RESIDENTIAL HORIZONTAL SIDEWALL SPRINKLER VK486 (K4.0)

The Viking Corporation, 210 N Industrial Park Drive, Hastings MI 49058  
 Telephone: 269-945-9501 Technical Services: 877-384-5464 Fax: 269-818-1680 Email: techsvcs@vikingcorp.com  
 Visit the Viking website for the latest edition of this technical data page: www.vikinggroupinc.com

### Approval Chart Viking VK486, 4.0 K-Factor Residential Horizontal Sidewall Sprinkler

For systems designed to NFPA 13D or NFPA 13R. For systems designed to NFPA 13, refer to the design criteria. For Ceiling types refer to current Editions of NFPA 13, 13R or 13D

Sprinkler Base Part Number <sup>1</sup>	SIN	NPT Thread Size		Nominal K-Factor		Maximum Water Working Pressure	Overall Length					
		Inches	mm	U.S.	metric <sup>2</sup>		Inches	mm				
17315	VK486	1/2	15	4.0	57.7	175 psi (12 bar)	2-7/16		62			
Max. Coverage Area <sup>3</sup> Width X Length Ft. X Ft. (m X m)	Max. Spacing Ft. (m)	Ordinary Temp Rating (155 °F/68 °C)		Intermediate Temp Rating (175 °F/79 °C)		Top of Deflector to Ceiling	Installation Type	Listings and Approvals <sup>4</sup>				Minimum Spacing Ft. (m)
		Flow <sup>3</sup> GPM (L/min)	Pressure <sup>3</sup> PSI (bar)	Flow <sup>3</sup> GPM (L/min)	Pressure <sup>3</sup> PSI (bar)			C-UL-US-EU <sup>5</sup>	VdS	NYC	NSF <sup>9</sup>	
12 X 12 (3.7 X 3.7)	12 (3.7)	11 (41.7)	7.6 (0.52)	11 (41.7)	7.6 (0.52)	4 to 6 inches	Standard surface-mounted escutcheons or recessed with the Micromatic® Model E-1, E-2, E-3, or G-1 Recessed Escutcheon	See Footnote 6 and 10.	See Footnote 6.	See Footnote 7.	See Footnote 6.	8 (2.4)
14 X 14 (4.3 X 4.3)	14 (4.3)	12 (45.5)	9 (0.62)	12 (45.5)	9 (0.62)							
16 X 16 (4.9 X 4.9)	16 (4.9)	13 (49.3)	10.6 (0.73)	13 (49.3)	10.6 (0.73)							
16 X 18 (4.9 X 5.5)	16 (4.9)	16 (60.6)	16 (1.10)	16 (60.6)	16 (1.10)							
16 X 20 (4.9 X 6.1)	16 (4.9)	22 (83.3)	30.3 (2.09)	22 (83.3)	30.3 (2.09)							
16 X 22 (4.9 X 6.7)	16 (4.9)	24 (90.8)	36 (2.48)	24 (90.8)	36 (2.48)							
18 X 18 (5.5 X 5.5)	18 (5.5)	18 (68.1)	20.3 (1.40)	19 (71.9)	22.6 (1.60)							
18 X 20 (5.5 X 6.1)	18 (5.5)	22 (83.3)	30.3 (2.09)	22 (83.3)	30.3 (2.09)							
12 X 12 (3.7 X 3.7)	12 (3.7)	12 (45.5)	9 (0.62)	12 (45.5)	9 (0.62)	6 to 12 inches						
14 X 14 (4.3 X 4.3)	14 (4.3)	12 (45.5)	9 (0.62)	13 (49.3)	10.6 (0.73)							
16 X 16 (4.9 X 4.9)	16 (4.9)	14 (53.0)	12.3 (0.84)	14 (53.0)	12.3 (0.84)							
16 X 18 (4.9 X 5.5)	16 (4.9)	16 (60.6)	16 (1.10)	16 (60.6)	16 (1.10)							
16 X 20 (4.9 X 6.1)	16 (4.9)	23 (87.1)	33.1 (2.28)	23 (87.1)	33.1 (2.28)							
16 X 22 (4.9 X 6.7)	16 (4.9)	26 (98.4)	42.3 (2.91)	26 (98.4)	42.3 (2.91)							
18 X 18 (5.5 X 5.5)	18 (5.5)	18 (68.1)	20.3 (1.40)	19 (71.9)	22.6 (1.60)							
18 X 20 (5.5 X 6.1)	18 (5.5)	23 (87.1)	33.1 (2.28)	23 (87.1)	33.1 (2.28)							
20 X 20 (6.1 X 6.1)	20 (6.1)	24 (90.8)	36 (2.48)	24 (90.8)	36 (2.48)							

#### Footnotes

- Part number shown is the base part number. For complete part number, refer to Viking's current price schedule.
- Metric K-factor measurement shown is when pressure is measured in Bar. When pressure is measured in kPa, divide the metric K-factor shown by 10.0.
- For areas of coverage smaller than shown, use the "Flow" and "Pressure" for the next larger area listed. Flows and pressures listed are per sprinkler. The distance from sprinklers to walls shall not exceed one-half the sprinkler spacing indicated for the minimum "Flow" and "Pressure" used.
- This chart shows the listings and approvals available at the time of printing. Other approvals may be in process. Check with the manufacturer for any additional approvals. Refer also to Design Criteria.
- Listed by Underwriter's Laboratories, Inc. for use in the U.S., Canada, and European Union.
- Approved Finishes are: Brass, Chrome, White Polyester, and Black Polyester <sup>8</sup>
- Meets New York City requirements, effective July 1, 2008.
- Other paint colors are available on request with the same C-UL-US-EU listings as the standard finish colors.
- UL Classified to : NSF/ANSI Standard 61, Drinking Water System Components (MH48034)
- Approved finish is Electroless Nickel PTFE (ENT). ENT is C-UL-US-EU Listed as corrosion resistant. ENT is available with standard surface-mounted escutcheons or the Micromatic Model E-1 Recessed Escutcheon.



**TECHNICAL DATA**

**FREEDOM® RESIDENTIAL HORIZONTAL SIDEWALL SPRINKLER VK486 (K4.0)**

The Viking Corporation, 210 N Industrial Park Drive, Hastings MI 49058  
 Telephone: 269-945-9501 Technical Services: 877-384-5464 Fax: 269-818-1680 Email: techsvcs@vikingcorp.com  
 Visit the Viking website for the latest edition of this technical data page: www.vikinggroupinc.com

**DESIGN CRITERIA**

(Also refer to the Approval Chart.)

**UL Listing Requirements (C-UL-US-EU):**

When using Viking Residential Horizontal Sidewall Sprinkler VK486 for systems designed to NFPA 13D or NFPA 13R, apply the listed areas of coverage and minimum water supply requirements shown in the Approval Chart.

For systems designed to NFPA 13: The number of design sprinklers is to be the four contiguous most hydraulically demanding sprinklers. The minimum required discharge from each of the four sprinklers is to be the greater of the following:

- The flow rates given in the Approval Chart for NFPA 13D and NFPA 13R applications for each listed area of coverage, **or**
- Calculated based on a minimum discharge of 0.1 gpm/sq. ft. over the “design area” in accordance with sections 8.5.2.1 or 8.6.2.1.2 of NFPA 13.
- Minimum distance between residential sprinklers: 8 ft. (2.4 m).
- The VK486 horizontal sidewall sprinkler deflector shall be located a minimum of 1-1/4” (31.8 mm) and a maximum of 6” (152 mm) from the wall on which it is installed.

**DEFLECTOR POSITION:** Install sprinkler VK486 with the leading edge of the deflector oriented parallel to the ceiling and the sprinkler frame arms oriented perpendicular to the ceiling (see Figure 4). **THE TOP SURFACE OF THE DEFLECTOR IS MARKED “TOP”.** The sprinkler must be oriented as shown in Figure 3 below.

**IMPORTANT: Always refer to Bulletin Form No. F\_091699 - Care and Handling of Sprinklers. Also refer to Form No. F\_080190, F\_080814, and F\_080415 for general care, installation, and maintenance information. Viking sprinklers are to be installed in accordance with the latest edition of Viking technical data, the appropriate standards of NFPA and any other similar Authorities Having Jurisdiction, and also with the provisions of governmental codes, ordinances, and standards, whenever applicable. Final approval and acceptance of all residential sprinkler installations must be obtained from the Authorities Having Jurisdiction.**

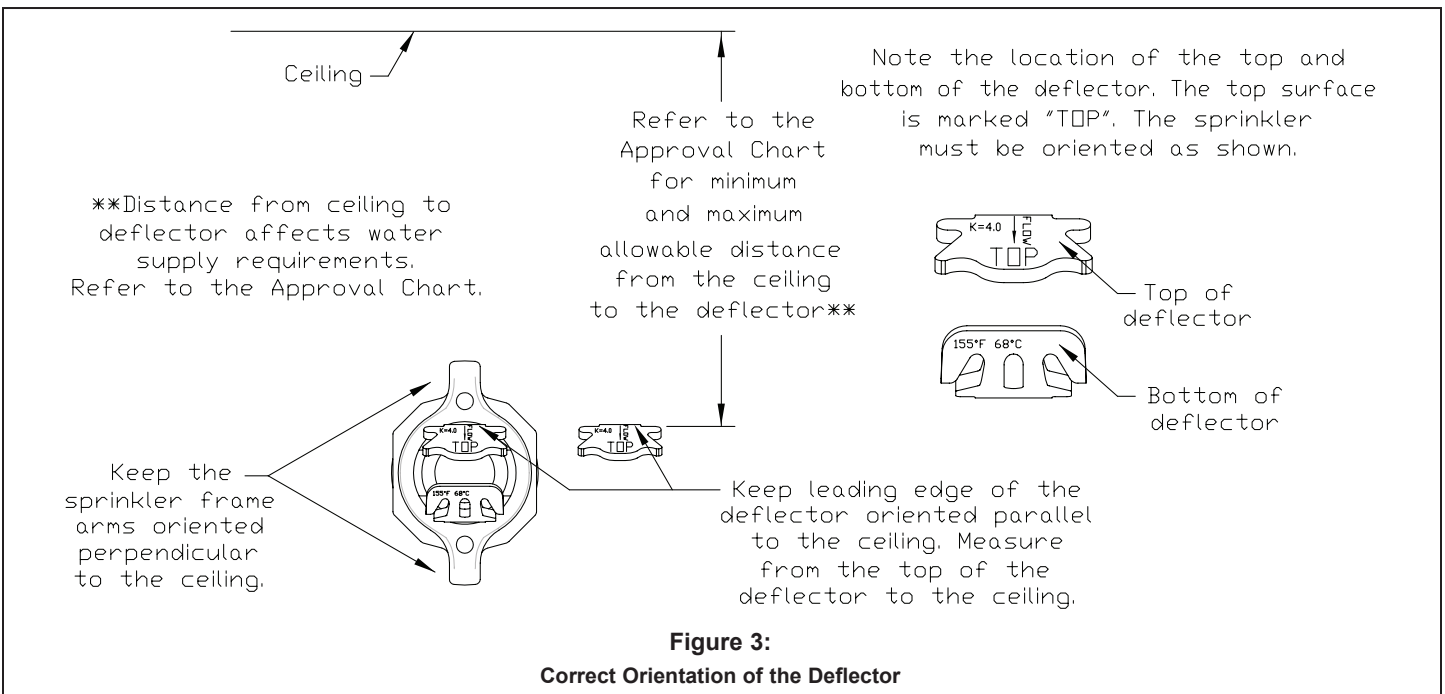

**Figure 3:**

**Correct Orientation of the Deflector**



**TECHNICAL DATA**

**FREEDOM® RESIDENTIAL  
HORIZONTAL SIDEWALL  
SPRINKLER VK486 (K4.0)**

The Viking Corporation, 210 N Industrial Park Drive, Hastings MI 49058  
 Telephone: 269-945-9501 Technical Services: 877-384-5464 Fax: 269-818-1680 Email: techsvcs@vikingcorp.com  
 Visit the Viking website for the latest edition of this technical data page: www.vikinggroupinc.com

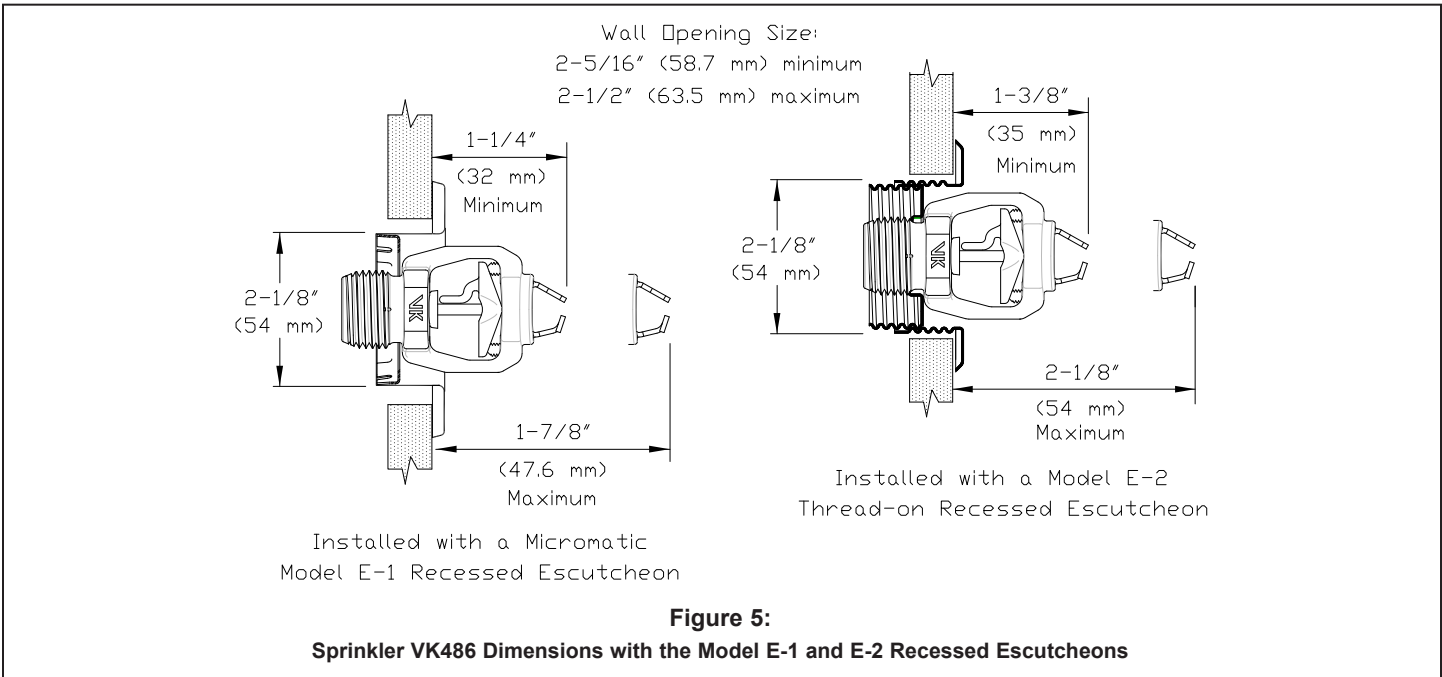
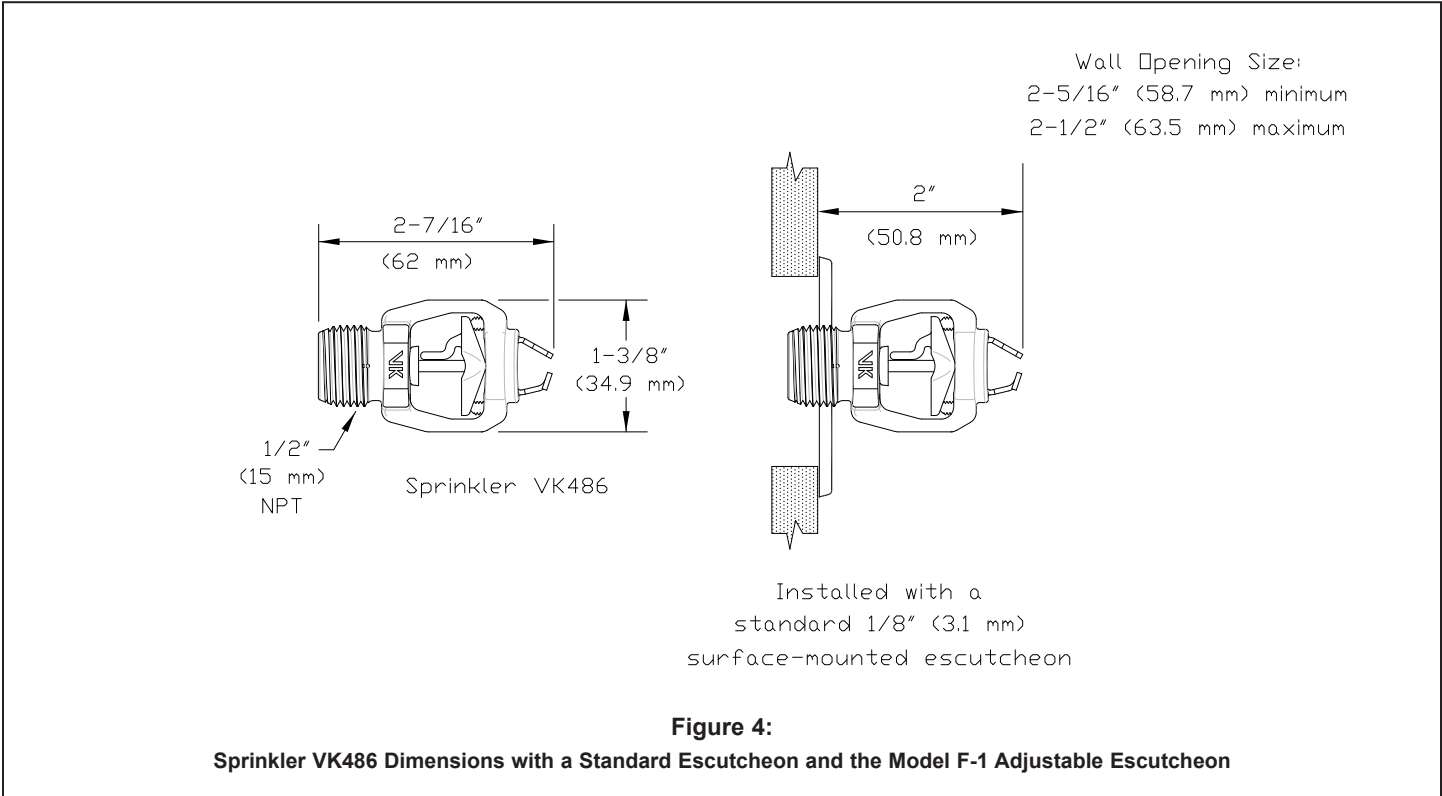



TECHNICAL DATA

FREEDOM® RESIDENTIAL HORIZONTAL SIDEWALL SPRINKLER VK486 (K4.0)

The Viking Corporation, 210 N Industrial Park Drive, Hastings MI 49058  
Telephone: 269-945-9501 Technical Services: 877-384-5464 Fax: 269-818-1680 Email: techsvcs@vikingcorp.com  
Visit the Viking website for the latest edition of this technical data page: www.vikinggroupinc.com

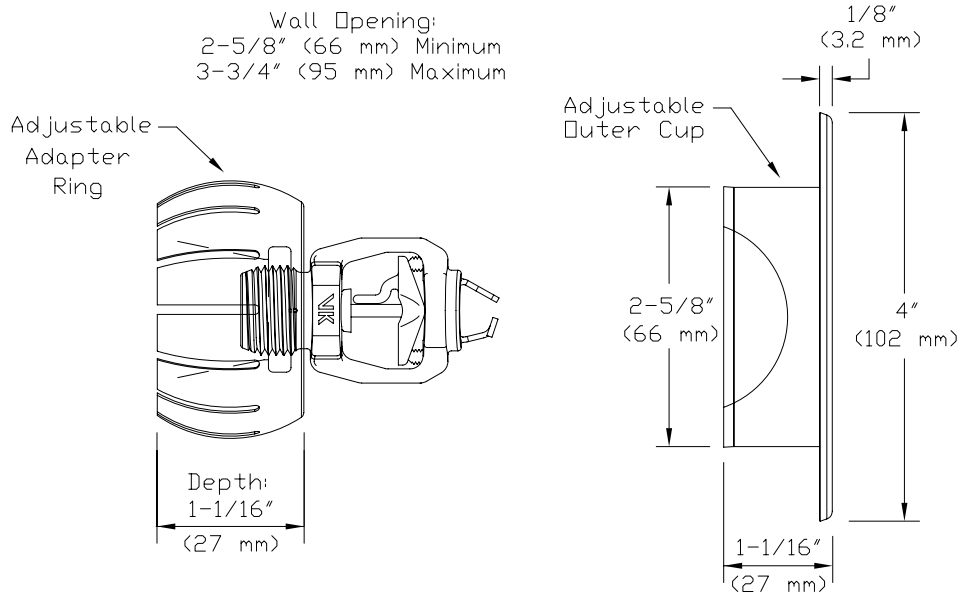

Figure 6: Sprinkler VK486 Dimensions with the Model G-1 Escutcheon



## TECHNICAL DATA

## QUICK RESPONSE DRY PENDENT SPRINKLERS

The Viking Corporation, 210 N Industrial Park Drive, Hastings MI 49058

Telephone: 269-945-9501 Technical Services: 877-384-5464 Fax: 269-818-1680 Email: techsvcs@vikingcorp.com

Visit the Viking website for the latest edition of this technical data page: [www.vikinggroupinc.com](http://www.vikinggroupinc.com)

### 1. DESCRIPTION

Viking Quick Response Dry Pendent Sprinklers are thermosensitive spray sprinklers suitable for use in areas subject to freezing. The sprinklers are designed for dry systems and preaction systems where it is necessary to prevent water or condensation from entering the drop nipple before sprinkler operation. They may also be installed in spaces subject to freezing and supplied from a wet system in an adjacent heated area.

Viking Quick Response Dry Pendent Sprinklers are available in various finishes and temperature ratings to meet design requirements. The special Polyester and Electroless Nickel PTFE (ENT) coatings have been investigated for installation in corrosive atmospheres and are listed/approved as corrosion resistant as indicated in the Approval Charts. (Note: FM Global has no approval classification for Polyester coatings as corrosion resistant.)

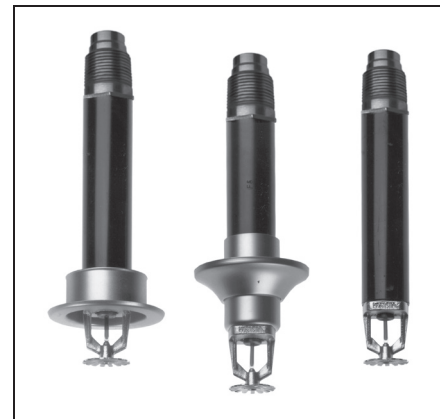

### 2. LISTINGS AND APPROVALS



**cULus Listed:** Category VNIV



**FM Approved:** Classes 2013 and 2015

**NYC Approved:** MEA 89-92-E Volume 15

Refer to Approval Chart 1 and Design Criteria on page 105d for cULus Listing requirements, and refer to Approval Chart 2 and Design Criteria on page 105e for FM Approval requirements that must be followed.



**WARNING:** Cancer and Reproductive Harm-  
[www.P65Warnings.ca.gov](http://www.P65Warnings.ca.gov)

### 3. TECHNICAL DATA

#### Specifications:

Minimum Operating Pressure: 7 psi (0.5 bar)

Maximum Working Pressure: 175 psi (12 bar).

Factory tested hydrostatically to 500 psi (34.5 bar)

Thread size: 1" NPT or 25 mm BSP

Nominal K-Factor: 5.6 U.S. (80.6 metric\*) for all listed and approved lengths.

\* Metric K-factor measurement shown is when pressure is measured in Bar. When pressure is measured in kPa, divide the metric K-factor shown by 10.0.

Glass-bulb fluid temperature rated to -65 °F (-55 °C)

Covered by the following U.S. Patents: 8,636,075 and 10,220,231

#### Material Standards:

Frame Casting: Brass UNS-C84400

Deflector: Brass UNS-C26000

Bulb: Glass, nominal 3 mm diameter

Belleville Spring Sealing Assembly: Nickel Alloy, coated on both sides with PTFE Tape

Compression Screw: Brass UNS-C36000

Pip Cap: Brass UNS-C31400 or UNS-C31600

Pip Cap Adapter: Brass UNS-C36000

Orifice: Copper UNS-C22000 or UNS-C11000

Tube: ERW Hydraulic Steel Tube

Support (Internal): Stainless Steel UNS-S30400

Barrel: Steel Pipe UNS-G10260, Electrodeposited Epoxy Base finish

Barrel End and Threads: QM Brass

Sleeve (for Adjustable Standard style only): Brass UNS-C26000 or UNS-C26800

#### Escutcheon Materials:

Adjustable Standard Dry Escutcheons: Brass UNS-C26000 or UNS-C26800

Recessed Dry Escutcheons: Cold Rolled Steel UNS-G10080

ENT Coated Adjustable and Recessed Escutcheons: Stainless Steel UNS-S30400

**Ordering Information:** (Also refer to the current Viking price list.)



## TECHNICAL DATA

## QUICK RESPONSE DRY PENDENT SPRINKLERS

The Viking Corporation, 210 N Industrial Park Drive, Hastings MI 49058

Telephone: 269-945-9501 Technical Services: 877-384-5464 Fax: 269-818-1680 Email: techsvcs@vikingcorp.com

Visit the Viking website for the latest edition of this technical data page: [www.vikinggroupinc.com](http://www.vikinggroupinc.com)

Order Quick Response Dry Pendent Sprinklers by first adding the appropriate suffix for the sprinkler finish, the appropriate suffix for the temperature rating, and then the suffix for the length ("A" dimension) to sprinkler base part number. Order in a specific length noted as the "A" dimension. The "A" dimension is the distance from the face of the fitting (tee) to the desired finished surface of the ceiling.

These sprinklers are listed and approved in lengths from 1-1/2" to 45-1/2" (38.1 mm to 1,156 mm) for the adjustable standard style, 3" to 47" (76.2 mm to 1,194 mm) for the plain barrel style, and 3-1/4" to 47-1/2" (82.5 mm to 1,207 mm) for the adjustable recessed style. Lengths exceeding the standard lengths are available, with no approvals, on a "made-to-order" basis: Recessed Dry Pendent up to 65-1/2" (1,664 mm). Adjustable Standard Dry Pendent up to 63-1/2" (1,613 mm). Plain Barrel Dry Pendent up to 65" (1,651 mm). Contact the manufacturer for more information.

Finish Suffix: Brass = A, Chrome = F, White Polyester = M-W, and ENT = JN

Temperature Suffix: 155 °F (68 °C) = B, 175 °F (79 °C) = D, 200 °F (93 °C) = E, 286 °F (141 °C) = G

For example, sprinkler VK176 with a Chrome finish and a 155 °F (68 °C) temperature rating, and "A" length of 10" = Part No. 08383UFB10.

**Available Finishes And Temperature Ratings:** Refer to Table 1.

**Accessories:** (Also refer to the "Sprinkler Accessories" section of the Viking data book.)

### Sprinkler Wrenches:

A. Standard Wrench: Part No. 07297W/B (available since 1991)

B. Wrench for recessed sprinklers: Part No. 07565W/B\*\* (available since 1991)

\*\*A 1/2" ratchet is required (not available from Viking).

**Sprinkler Guard:** Chrome, with no listings or approvals, for installation on dry pendent sprinklers made after May 1994 only (Part No. 08954).

### Replacement Escutcheons:

A. Adjustable Standard Dry Escutcheon: Base Part No. 07741

B. Recessed Dry Escutcheon Cup: Base Part No. 05459A

## 4. INSTALLATION

Refer to appropriate NFPA Installation Standards.

## 5. OPERATION

During fire conditions, the heat-sensitive liquid in the glass bulb expands, causing the glass to shatter, releasing the internal parts to open the waterway. Water flowing through the sprinkler orifice strikes the sprinkler deflector, forming a uniform spray pattern to extinguish or control the fire.

## 6. INSPECTIONS, TESTS & MAINTENANCE

Refer to NFPA 25 for Inspection, Testing and Maintenance requirements.

## 7. AVAILABILITY

The Viking Quick Response Dry Pendent Sprinkler is available through a network of domestic and international distributors. See The Viking Corporation web site for the closest distributor or contact The Viking Corporation.

## 8. GUARANTEE

For details of warranty, refer to Viking's current list price schedule or contact Viking directly.

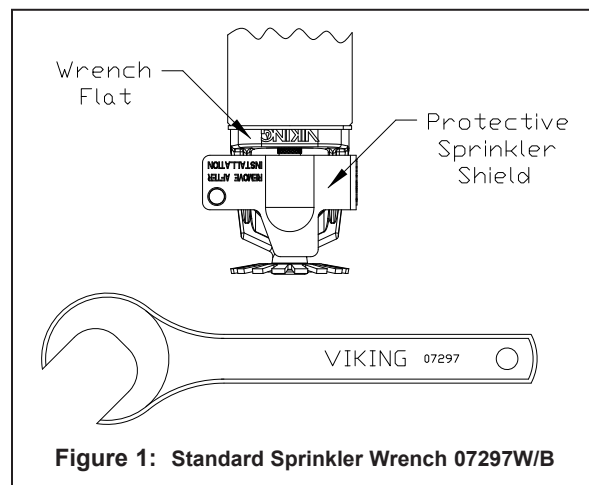

Figure 1: Standard Sprinkler Wrench 07297W/B

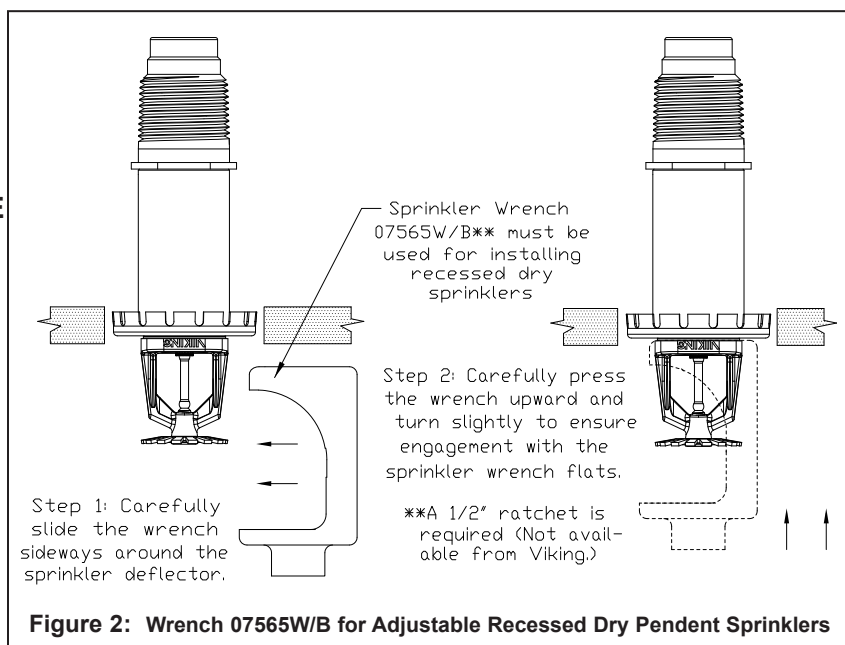

Figure 2: Wrench 07565W/B for Adjustable Recessed Dry Pendent Sprinklers





**TECHNICAL DATA**

**QUICK RESPONSE  
DRY PENDENT SPRINKLERS**

The Viking Corporation, 210 N Industrial Park Drive, Hastings MI 49058  
 Telephone: 269-945-9501 Technical Services: 877-384-5464 Fax: 269-818-1680 Email: techsvcs@vikingcorp.com  
 Visit the Viking website for the latest edition of this technical data page: www.vikinggroupinc.com

**TABLE 1: AVAILABLE SPRINKLER TEMPERATURE RATINGS AND FINISHES**

Sprinkler Temperature Classification	Sprinkler Nominal Temperature Rating <sup>1</sup>	Maximum Ambient Ceiling Temperature <sup>2</sup>	Bulb Color
Ordinary	155 °F (68 °C)	100 °F (38 °C)	Red
Intermediate	175 °F (79 °C)	150 °F (65 °C)	Yellow
Intermediate	200 °F (93 °C)	150 °F (65 °C)	Green
High	286 °F (141 °C)	225 °F (107 °C)	Blue

**Sprinkler Finishes:** Brass, Chrome, White Polyester, and ENT

**Corrosion-Resistant Coating<sup>3,4</sup>:** White Polyester and ENT in all temperature ratings

**Footnotes**

<sup>1</sup> The sprinkler temperature rating is stamped on the deflector.

<sup>2</sup> Based on NFPA-13. Other limits may apply, depending on fire loading, sprinkler location, and other requirements of the Authority Having Jurisdiction. Refer to specific installation standards.

<sup>3</sup> The corrosion-resistant Polyester and ENT coatings have passed the standard corrosion test required by the approving agencies indicated in the Approval Charts. These tests cannot and do not represent all possible corrosive environments. Note: These coatings are NOT corrosion proof. Prior to installation, verify through the end-user that the coatings are compatible with or suitable for the proposed environment. Polyester and ENT coatings are applied to the exposed exterior surfaces only. Note that the spring is exposed on sprinklers with Polyester and ENT coatings.

<sup>4</sup> When installed in some corrosive environments, the Polyester finish may change color. This natural discoloration over time is not in itself an indication of corrosion and should not be treated as such. All sprinklers installed in corrosive environments should be replaced or tested as described in NFPA 25 on a more frequent basis.

For "A" Dimension: 1. Determine the distance from the face of the tee to the finished ceiling.

2. Round to the nearest 1/2" (12.7 mm) between 1-1/2" and 45-1/2" (38.1 mm and 1,156 mm).

NOTE: The deflector will be located approximately 3-7/16" (87.3 mm) below the ceiling, with 1" (25.4 mm) upward and 1" (25.4 mm) downward adjustment.

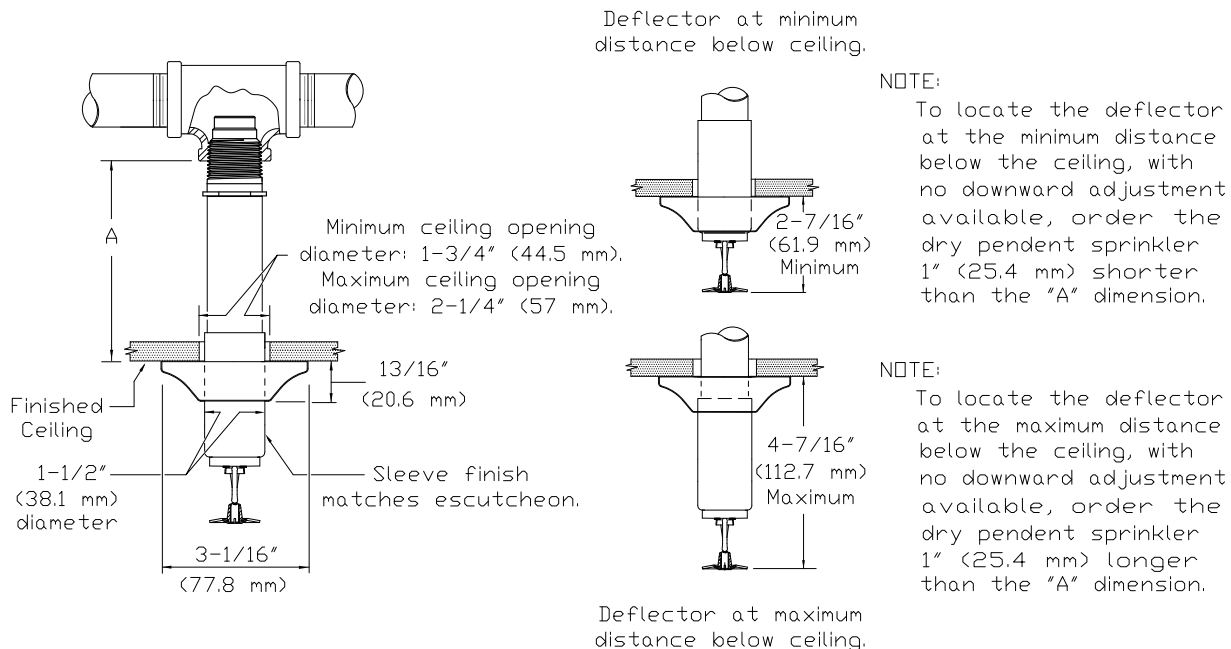

**Figure 3: Adjustable Standard Dry Pendent Sprinkler**

	<h2 style="margin: 0;">TECHNICAL DATA</h2>	<h2 style="margin: 0;">QUICK RESPONSE DRY PENDENT SPRINKLERS</h2>
---	--	---

**The Viking Corporation, 210 N Industrial Park Drive, Hastings MI 49058**  
**Telephone: 269-945-9501 Technical Services: 877-384-5464 Fax: 269-818-1680 Email: techsvcs@vikingcorp.com**  
**Visit the Viking website for the latest edition of this technical data page: www.vikinggroupinc.com**

<b>Approval Chart 1 (UL)</b> Quick Response Dry Pendent Sprinklers Maximum 175 PSI (12 bar) WWP														
Sprinkler Base Part No. <sup>1</sup>	SIN	Style	Thread Size		Nominal K-Factor <sup>2</sup>		Order Length Increment		Listings and Approvals <sup>4</sup> (Refer also to Design Criteria below.)					
			NPT	BSP	U.S.	metric <sup>3</sup>	Inches	mm	cULus <sup>5</sup>	NYC <sup>6</sup>	VdS	LPCB	CE	
08383U	VK176	Adjustable	1"	--	5.6	80.6	1/2"	12.7	A1, A5	A1	--	--	--	--
16457U		Standard	--	25 mm	--	80.6	1/2"	12.7	A1, A5	--	--	--	--	--
08385U	VK180	Adjustable	1"	--	5.6	80.6	1/4"	6.35	B2, B6	B2	--	--	--	--
16453U		Recessed	--	25 mm	--	80.6	1/4"	6.35	B2, B6	--	--	--	--	--
08387U	VK172	Plain	1"	--	5.6	80.6	1/2"	12.7	A3	A4	--	--	--	--
16455U		Barrel	--	25 mm	--	80.6	1/2"	12.7	A3	--	--	--	--	--
<b>Approved Temperature Ratings</b> A - 155 °F (68 °C), 175 °F (79°C), 200 °F (93 °C), and 286 °F (141 °C) B - 155 °F (68 °C), 175 °F (79°C), and 200 °F (93 °C)					<b>Approved Finishes and "A" Dimensions</b> 1 - Chrome or White Polyester <sup>7</sup> sprinkler with a Chrome or White Polyester Sleeve and Escutcheon with "A" dimensions 1-1/2" to 45-1/2" (38.1 mm to 1,156 mm) 2 - Chrome or White Polyester <sup>7</sup> with "A" dimensions 3-1/4" to 47-1/2" (82.5 mm to 1,207 mm) 3 - Chrome, Brass, White Polyester <sup>7</sup> , or ENT <sup>7</sup> with "A" dimensions 3" to 47" (76.2 mm to 1,194 mm) 4 - Chrome or Brass with "A" dimensions 3" to 47" (76.2 mm to 1,194 mm) 5 - ENT <sup>7</sup> sprinkler with an ENT <sup>7</sup> Sleeve and Escutcheon with "A" dimensions 1-1/2" to 45-1/2" (38.1 mm to 1,156 mm) 6 - ENT <sup>7</sup> with "A" dimensions 3-1/4" to 47-1/2" (82.5 mm to 1,207 mm)									
<b>Footnotes</b>														
<sup>1</sup> Part number shown is the base part number. For complete part number, refer to current Viking price list schedule. <sup>2</sup> K-Factor applies for standard lengths ("A" Dimensions indicated above). <sup>3</sup> Metric K-factor measurement shown is when pressure is measured in Bar. When pressure is measured in kPa, divide the metric K-factor shown by 10.0. <sup>4</sup> This chart shows the listings and approvals available at the time of printing. Other approvals may be in process. Check with the manufacturer for any additional approvals. <sup>5</sup> Listed by Underwriter's Laboratories for use in the U.S. and Canada. <sup>6</sup> Accepted for use, City of New York Department of Buildings, MEA Number 89-92-E, Vol. 15. <sup>7</sup> cULus Listed as corrosion resistant.														

<b>DESIGN CRITERIA - UL</b> (Also refer to Approval Chart 1 above.)
<b>NOTE: When using CPVC fittings with Viking dry sprinklers, use only new Nibco Model 5012-S-BI tees. When selecting other CPVC fittings, contact Viking Technical Services.</b>
<b>cULus Listing Requirements:</b> Standard Dry Pendent Sprinklers are cULus Listed as indicated in Approval Chart 1 for installation in accordance with the latest edition of NFPA 13 for standard spray sprinklers. <ul style="list-style-type: none"> <li>• Designed for use in Light and Ordinary Hazard occupancies.</li> <li>• The sprinkler installation and obstruction rules contained in NFPA 13 for standard spray pendent sprinklers must be followed.</li> </ul>
<b>IMPORTANT: Always refer to Bulletin Form No. F_091699 - Care and Handling of Sprinklers. Also refer to Form F_080614 for general care, installation, and maintenance information. Viking sprinklers are to be installed in accordance with the latest edition of Viking technical data, the appropriate standards of NFPA, LPCB, APSAD, VdS or other similar organizations, and also with the provisions of governmental codes, ordinances, and standards, whenever applicable.</b>



**TECHNICAL DATA**

**QUICK RESPONSE  
DRY PENDENT SPRINKLERS**

The Viking Corporation, 210 N Industrial Park Drive, Hastings MI 49058  
 Telephone: 269-945-9501 Technical Services: 877-384-5464 Fax: 269-818-1680 Email: techsvcs@vikingcorp.com  
 Visit the Viking website for the latest edition of this technical data page: www.vikinggroupinc.com

Approval Chart 2 (FM) Quick Response Dry Pendent Sprinklers Maximum 175 PSI (12 bar) WWP									
Sprinkler Base Part No. <sup>1</sup>	SIN	Style	Thread Size		Nominal K-Factor <sup>2</sup>		Order Length Increment		FM Approvals <sup>4</sup> (Refer also to Design Criteria below.)
			NPT	BSP	U.S.	metric <sup>3</sup>	Inches	mm	
08383U	VK176	Adjustable Standard	1"	--	5.6	80.6	1/2"	12.7	A1
16457U			--	25 mm	--	80.6	1/2"	12.7	A1
08385U	VK180	Adjustable Recessed	1"	--	5.6	80.6	1/4"	6.35	B2
16453U			--	25 mm	--	80.6	1/4"	6.35	B2
08387U	VK172	Plain Barrel	1"	--	5.6	80.6	1/2"	12.7	A3
16455U			--	25 mm	--	80.6	1/2"	12.7	A3

**Approved Temperature Ratings**  
 A - 155 °F (68 °C), 175 °F (79 °C), 200 °F (93 °C), and 286 °F (141 °C)  
 B - 155 °F (68 °C), 175 °F (79 °C), and 200 °F (93 °C)

**Approved Finishes and "A" Dimensions**  
 1 - Brass, Chrome, White Polyester, or ENT<sup>5</sup> sprinkler with a Brass, Chrome, White Polyester, or ENT<sup>5</sup> Sleeve and Escutcheon with "A" dimensions 1-1/2" to 45-1/2" (38.1 mm to 1,156 mm)  
 2 - Brass, Chrome, White Polyester, or ENT<sup>5</sup> with "A" dimensions 3-1/4" to 47-1/2" (82.5 mm to 1,207 mm)  
 3 - Brass, Chrome, White Polyester, or ENT<sup>5</sup> with "A" dimensions 3" to 47" (76.2 mm to 1,194 mm)

**Footnotes**  
<sup>1</sup> Part number shown is the base part number. For complete part number, refer to current Viking price list schedule.  
<sup>2</sup> K-Factor applies for standard lengths ("A" Dimensions indicated above).  
<sup>3</sup> Metric K-Factor measurement shown is when pressure is measured in Bar. When pressure is measured in kPa, divide the metric K-factor shown by 10.0.  
<sup>4</sup> This chart shows the FM Approvals available at the time of printing. Other approvals may be in process. Check with the manufacturer for any additional approvals.  
<sup>5</sup> FM approved as corrosion resistant.

**DESIGN CRITERIA - FM**  
(Also refer to Approval Chart 2 above.)

**NOTE: When using CPVC fittings with Viking dry sprinklers, use only new Nibco Model 5012-S-BI tees. When selecting other CPVC fittings, contact Viking Technical Services.**

**FM Approval Requirements:**

The Dry Pendent Sprinklers in the Approval Chart above are FM Approved as quick response **Non-storage** standard spray sprinklers as indicated in the FM Approval Guide. For specific application and installation requirements, reference the latest applicable FM Loss Prevention Data Sheets (including 2-0) and Technical Advisory Bulletins. FM Global Loss Prevention Data Sheets and Technical Advisory Bulletins contain guidelines relating to, but not limited to: minimum water supply requirements, hydraulic design, ceiling slope and obstructions, minimum and maximum allowable spacing, and deflector distance below the ceiling.

**NOTE: The FM installation guidelines may differ from cULus and/or NFPA criteria.**

**IMPORTANT: Always refer to Bulletin Form No. F\_091699 - Care and Handling of Sprinklers. Also refer to Form F\_080614 for general care, installation, and maintenance information. Viking sprinklers are to be installed in accordance with the latest edition of Viking technical data, the appropriate standards of NFPA, FM Global, LPCB, APSAD, VdS or other similar organizations, and also with the provisions of governmental codes, ordinances, and standards, whenever applicable.**

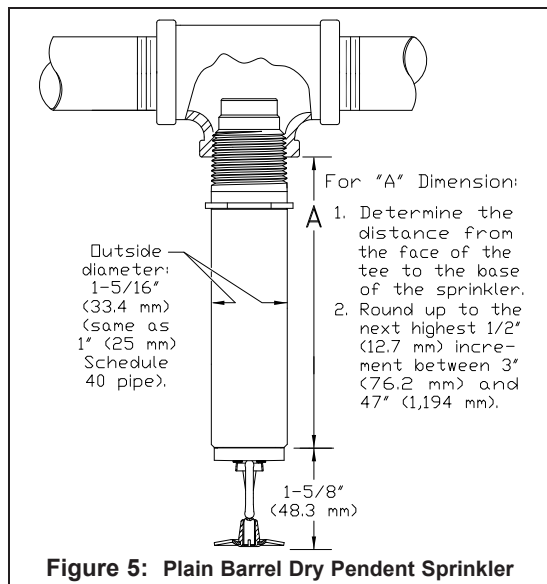
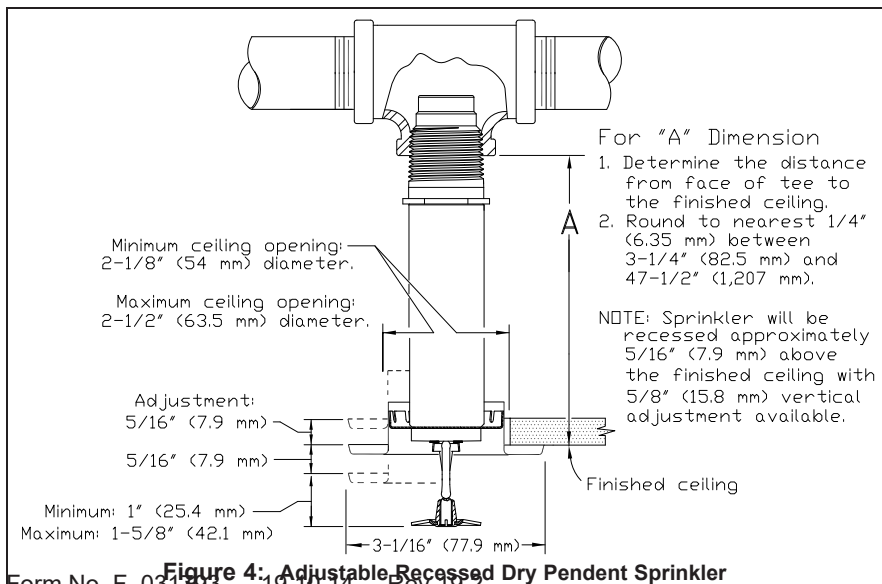

**Figure 4: Adjustable Recessed Dry Pendent Sprinkler**

**Figure 5: Plain Barrel Dry Pendent Sprinkler**



TECHNICAL DATA

QUICK RESPONSE DRY PENDENT SPRINKLERS

The Viking Corporation, 210 N Industrial Park Drive, Hastings MI 49058

Telephone: 269-945-9501 Technical Services: 877-384-5464 Fax: 269-818-1680 Email: techsvcs@vikingcorp.com

Visit the Viking website for the latest edition of this technical data page: www.vikinggroupinc.com

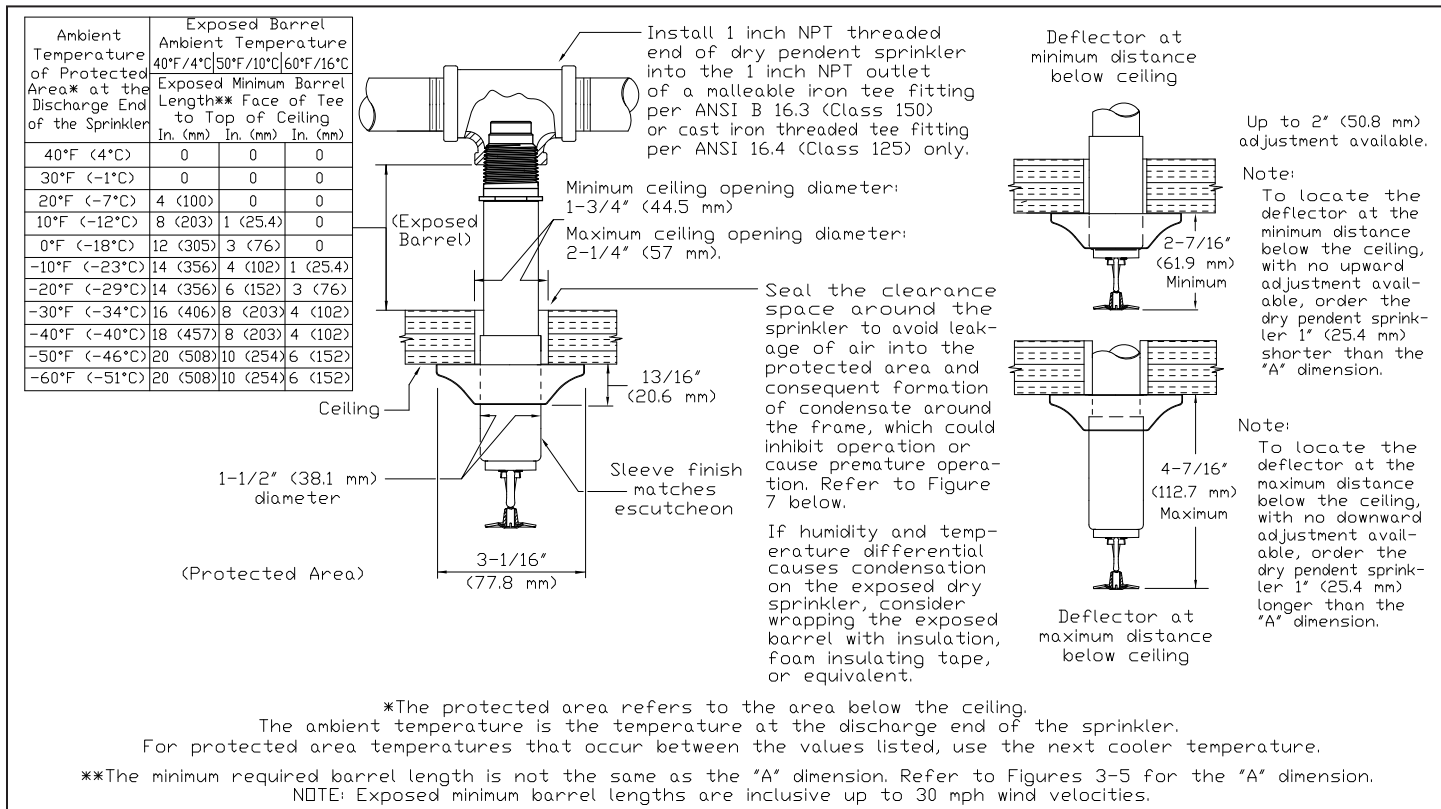

Figure 6: Dry Pendent Sprinkler Required Minimum Barrel Length Based on Ambient Temperature in the Protected Area (Adjustable Standard Dry Pendent Sprinkler is Shown)

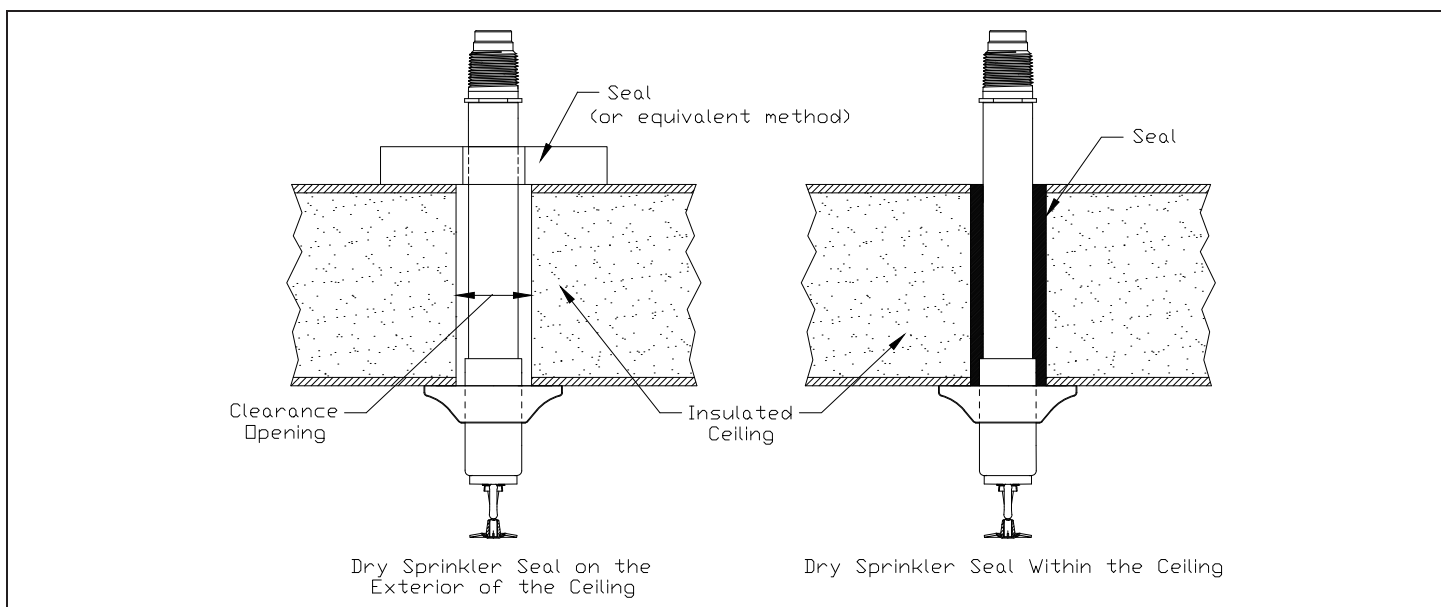

Figure 7: Dry Sprinkler Seal (Adjustable Standard Dry Pendent Sprinkler is Shown)

# VicFlex™ Style VS1 Dry Sprinkler

Models V3505, V3506, V3509, V3510, V3517, V3518



10.91



## 1.0 PRODUCT DESCRIPTION

### Style

- Pendent, Concealed Pendent, Horizontal Sidewall

### K Factor

- 5.6/8.1 S.I.  
For system design purposes, no equivalent length calculations are required.

### Sprinkler Length

- 38"/965 mm, 50"/1270 mm, 58"/1475 mm

### Nominal Orifice Size

- ½"/13 mm

### Maximum Working Pressure

- 175 psi/1200 kPa

### Factory Hydrostatic Test

- 100% @ 500 psi/3450 kPa

### Minimum Operating Pressure

- 7 psi/48 kPa

### Connections

- To branch line (inlet) via 1"/25 mm NPT or 1" BSPT

### Minimum Bend Radius:

- **UL:** 2"/51 mm
- **FM:** 7"/178 mm

### Maximum Number of 90° Bends:

- **UL:** 4
- **FM:** 2 bends for 38", 3 bends for 50", 4 bends for 58"

### Hazard Classifications

- Light and Ordinary Hazard

### NOTE

- The VS1 is classified as a dry sprinkler and has no equivalent length.

ALWAYS REFER TO ANY NOTIFICATIONS AT THE END OF THIS DOCUMENT REGARDING PRODUCT INSTALLATION, MAINTENANCE OR SUPPORT.

System No.		Location	
Submitted By		Date	

Spec Section		Paragraph	
Approved		Date	



## 2.0 CERTIFICATION/LISTINGS

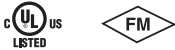

Approvals/Listings	Model								
	V3505	V3505	V3506	V3506	V3509	V3509	V3510	V3517	V3518
Orifice Size (inches)	1/2"	1/2"	1/2"	1/2"	1/2"	1/2"	1/2"	1/2"	1/2"
Orifice Size (mm)	13	13	13	13	13	13	13	13	13
Nominal K Factor Imperial	5.6	5.6	5.6	5.6	5.6	5.6	5.6	5.6	5.6
Nominal K Factor S.I.	8.1	8.1	8.1	8.1	8.1	8.1	8.1	8.1	8.1
Response	Standard	Standard	Quick	Quick	Standard	Standard	Quick	Standard	Quick <sup>1</sup>
Deflector Type	Pendent	Recessed	Pendent	Recessed	Hor. SW	Rec. Hor. SW	Hor. SW, Recessed Hor. Sidewall	Conc. Pend.	Conc. Pend. w/Clean room gasket
Approved Temperature Ratings	F°/C°								
FM	135/57	135/57	135/57	135/57	135/57	135/57	135/57	–	135/57
	155/68	155/68	155/68	155/68	155/68	155/68	155/68	–	155/68
	175/79	175/79	175/79	175/79	175/79	175/79	175/79	–	175/79
	200/93	200/93	200/93	200/93	200/93	200/93	200/93	–	200/93
UL	286/141	–	–	–	286/141	–	–	–	–
	135/57	135/57	135/57	135/57	135/57	135/57	135/57	135/57	135/57
	155/68	155/68	155/68	155/68	155/68	155/68	155/68	155/68	155/68
	175/79	175/79	175/79	175/79	175/79	175/79	175/79	175/79	175/79
	200/93	200/93	200/93	200/93	200/93	200/93	200/93	200/93	200/93
	286/141	286/141	286/141	286/141	286/141	–	286/141	–	–

<sup>1</sup> Model V3518 is a Standard Response FM sprinkler.

## 3.0 MATERIAL SPECIFICATIONS

**Deflector:** Brass

**Bulb:** Glass with glycerin solution

**Bulb Nominal Diameter:**

**Quick Response:** 3.0 mm

**Standard Response:** 5.0 mm

**Split Spacers:** Stainless steel

**Load Screw:** Brass

**Pip Cap:** Stainless steel

**Spring Seal Assembly:** PTFE tape coated beryllium nickel and stainless steel

**Frame:** Brass

**Flexible Hose:** Stainless steel

**Collar/Weld Fitting:** Stainless steel

**Gasket Seal:** Victaulic EPDM

**Isolation Ring:** Nylon

**Hose Fittings:** Carbon steel, zinc-plated

**Inlet Fitting:** Brass

**Outer Tube:** Stainless steel

**Concealed Cup:** Carbon steel, zinc-plated

**Brackets:** Carbon steel, zinc-plated

## 3.1 ACCESSORIES SPECIFICATIONS

**Sprinkler Finishes:**

**Standard:** VC-250

White painted RAL 9010

## 4.0 DIMENSIONS

### Product Details and Optional Components

#### Style VS1 Dry Sprinkler

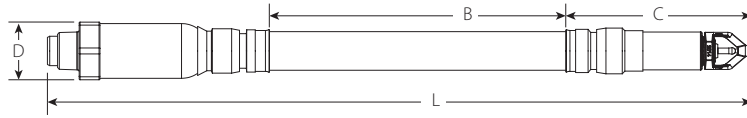

Sprinkler Length inches mm	Overall Length (pendent)	Live Length	Outlet End Length	Maximum OD
	L inches mm	B inches mm	C inches mm	D inches mm
38 965	39.2 995	25.1 638	6.5 165	2.2 56
50 1270	51.2 1300	37.1 943	6.5 165	2.2 56
58 1475	59.2 1505	45.1 1145	6.5 165	2.2 56

**NOTE**

- Add 1/2" to Overall Length and Outlet End Length for increased length of sidewall deflector

#### Style VB1 Bracket

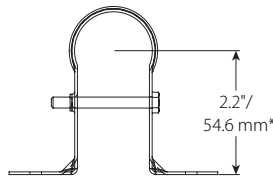
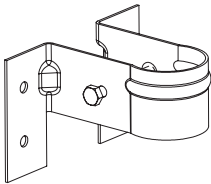

\*Note: Theoretical center point of sprinkler in bracket.

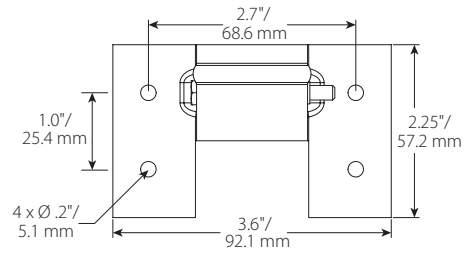

4.0 DIMENSIONS (CONTINUED)

**Style VB2 Bracket**  
Recessed Pendant, Suspended Ceilings

Item	Description
1	24"/610 mm or 48"/1220 mm Square Bar
2	Patented 1-Bee Center Bracket
3	End Bracket

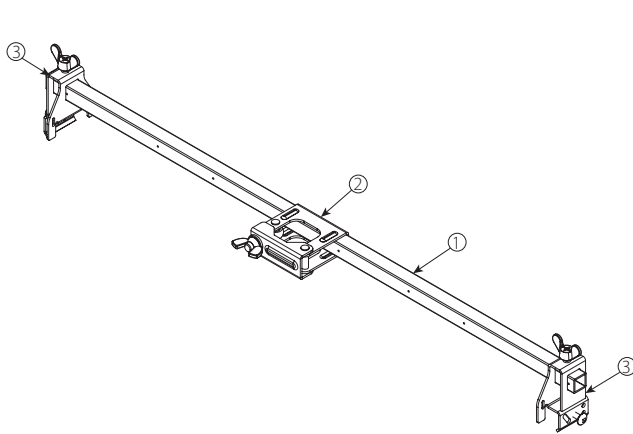

**Style VB3 Bracket**  
Concealed Pendant, Suspended Ceilings

Item	Description
1	24"/610 mm or 48"/1220 mm Square Bar
2	Patented 1-Bee Center Bracket
3	End Bracket

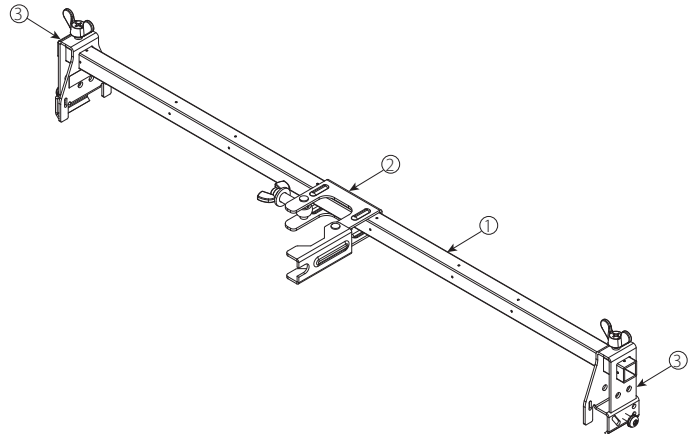

**Style VB4 Bracket**  
Sleeve and Skirt Pendant, Suspended Ceilings

Item	Description
1	24"/610 mm or 48"/1220 mm Square Bar
2	Center Bracket
3	End Bracket

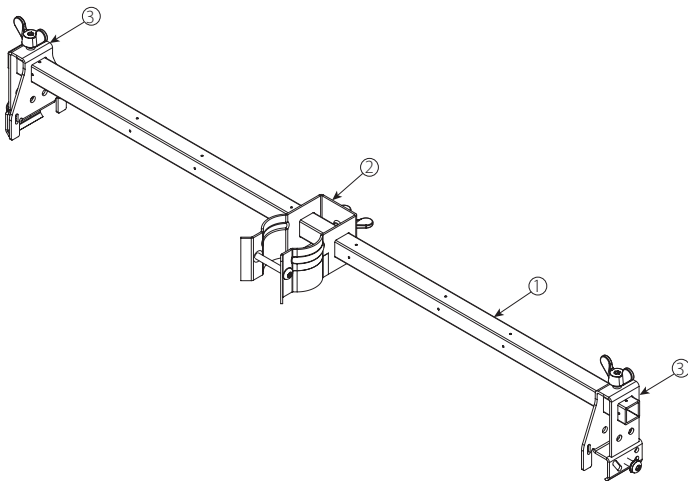



## 4.1 DIMENSIONS

### Sprinkler Finishes: Dimensions and Mounting Conditions

**NOTE**

- Drawings are shown with 5/8" finished ceiling thickness. Adjustments to "B" and "C" dimensions will be required if finished ceiling thickness deviate from drawing.

**Recessed Pendant:**

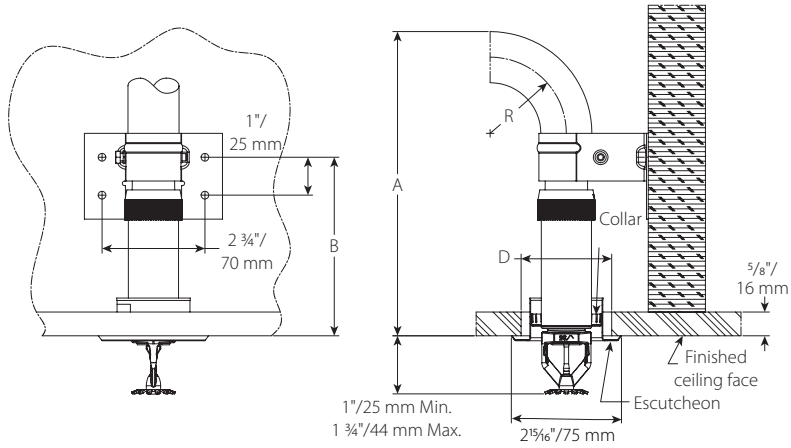

**Clearance Chart**

Dimension	inches	
	mm	
"R" Minimum Bend Radius	2 50	7 175
"A" Minimum Required Installation Space	7 5/8 193	12 5/8 320
"B" Mounting Screw Hole Location	4 3/4 119	
Ceiling Hole Diameter "D"	2 - 2 3/8 50 - 60	

**NOTE**

- Dimensions are shown with 3/4" escutcheon at middle of height adjustment range.

## 4.2 DIMENSIONS

### Recessed Pendant Alternative Bracket Location

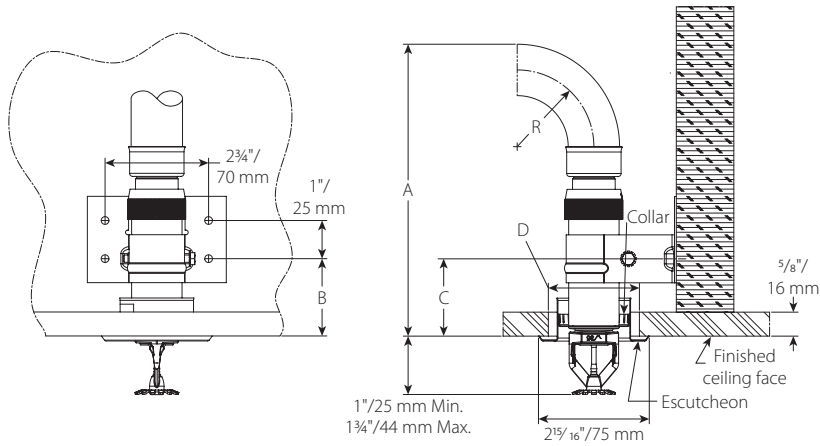

**Clearance Chart**

Dimension	inches mm	
	"R" Minimum Bend Radius	2 50
"A" Minimum Required Installation Space	7 5/8 193	12 5/8 320
"B" Mounting Screw Hole Location	2 50	
Ceiling Hole Diameter "D"	2 - 2 3/8 50 - 60	

**NOTE**

- Dimensions are shown with 3/4" escutcheon at middle of height adjustment range.

### 4.3 DIMENSIONS

#### Sleeve and Skirt Pendant

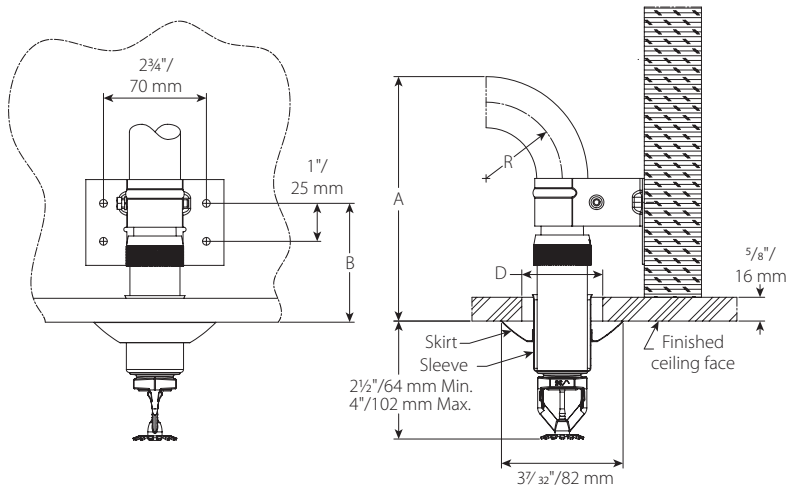

Clearance Chart		
Dimension	inches mm	
"R" Minimum Bend Radius	2 50	7 175
"A" Minimum Required Installation Space	6½ 163	11½ 290
"B" Mounting Screw Hole Location	3 ⅛ 79	
Ceiling Hole Diameter "D"	1¾ – 2½ 44 – 54	

### 4.4 DIMENSIONS

#### Concealed Pendant

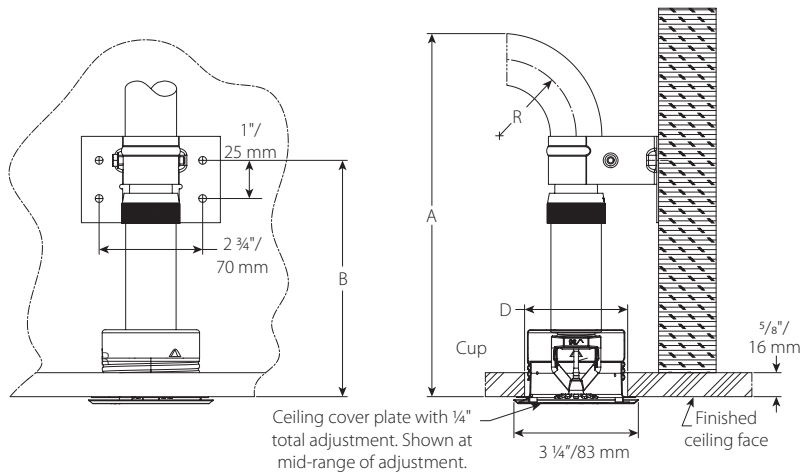

Clearance Chart		
Dimension	inches mm	
"R" Minimum Bend Radius	2 50	7 175
"A" Minimum Required Installation Space	9½ 241	14½ 369
"B" Mounting Screw Hole Location	6¼ 157	
Ceiling Hole Diameter "D"	2⅝ – 2¾ 67 – 70	

## 4.5 DIMENSIONS

### Concealed Pendant Alternative Bracket Location

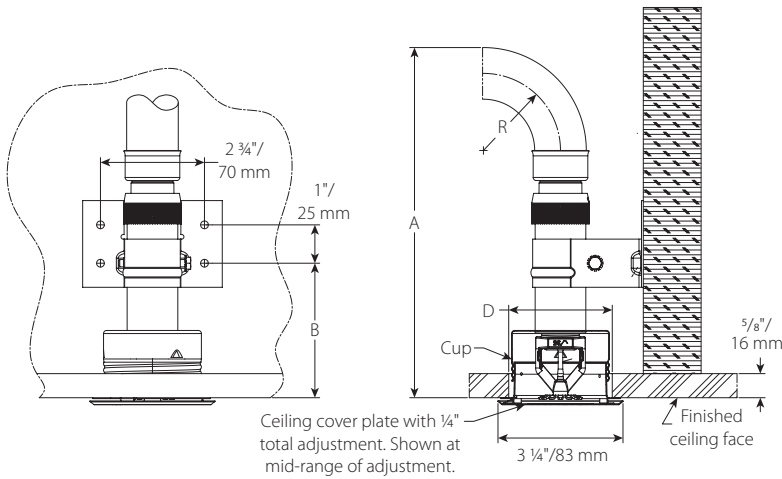

Clearance Chart		
Dimension	inches mm	
"R" Minimum Bend Radius	2 50	7 175
"A" Minimum Required Installation Space	9 1/8 231	14 1/8 358
"B" Mounting Screw Hole Location	3 1/2 89	
Ceiling Hole Diameter "D"	2 5/8 - 2 3/4 67 - 70	

## 4.6 DIMENSIONS

### Sleeve and Skirt Sidewall

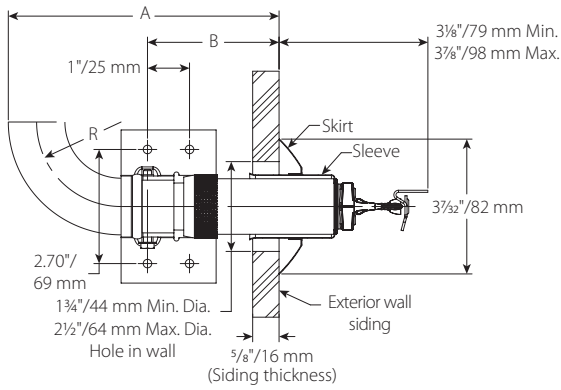

Clearance Chart		
Dimension	inches mm	
"R" Minimum Bend Radius	2 50	7 175
"A" Minimum Required Installation Space	6 1/2 163	11 1/2 290
"B" Mounting Screw Hole Location	3 1/8 79	
Ceiling Hole Diameter "D"	1 3/4 - 2 1/8 44 - 54	

## 4.7 DIMENSIONS

### Recessed Sidewall

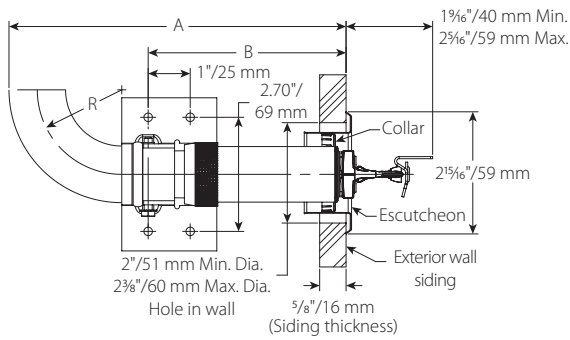

Clearance Chart		
Dimension	inches mm	
"R" Minimum Bend Radius	2 50	7 175
"A" Minimum Required Installation Space	8 203	13 330
"B" Mounting Screw Hole Location	4 3/4 119	
Ceiling Hole Diameter "D"	2 - 2 3/8 51 - 60	

## 4.8 DIMENSIONS

### Recessed Sidewall Alternative Bracket Location

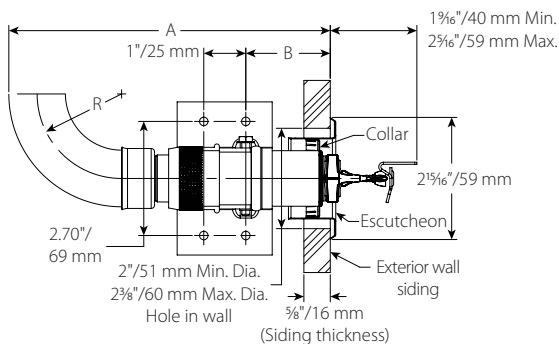

Clearance Chart		
Dimension	inches mm	
"R" Minimum Bend Radius	2 50	7 175
"A" Minimum Required Installation Space	8 203	13 330
"B" Mounting Screw Hole Location	2 51	
Ceiling Hole Diameter "D"	2 - 2 3/8 51 - 60	

## 4.9 DIMENSIONS

### VB2 Recessed Pendant

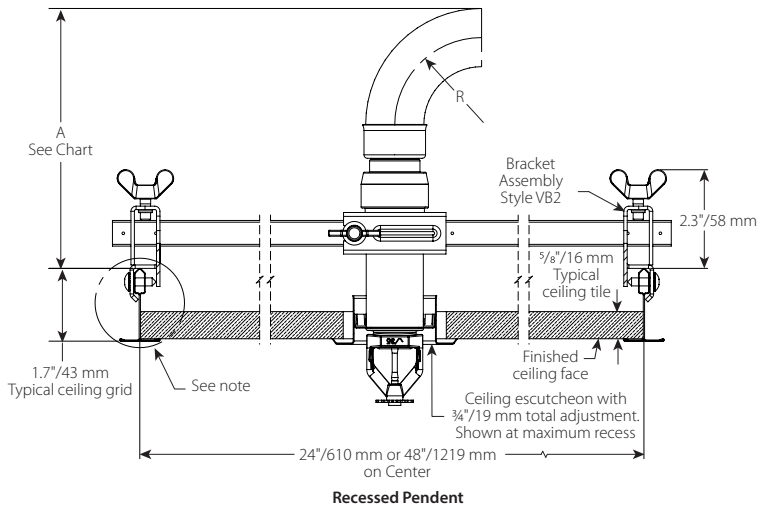

Clearance Chart		
Dimension	inches mm	
"R" Minimum Bend Radius	2	7
	50	175
"A" Minimum Required Installation Space	6½	11½
	163	290

**NOTE**

- Victaulic *VicFlex* Style VB2 Bracket assemblies shall be used only with Style VS1 recessed pendant sprinklers.

## 4.10 DIMENSIONS

### VB3 Concealed Pendant

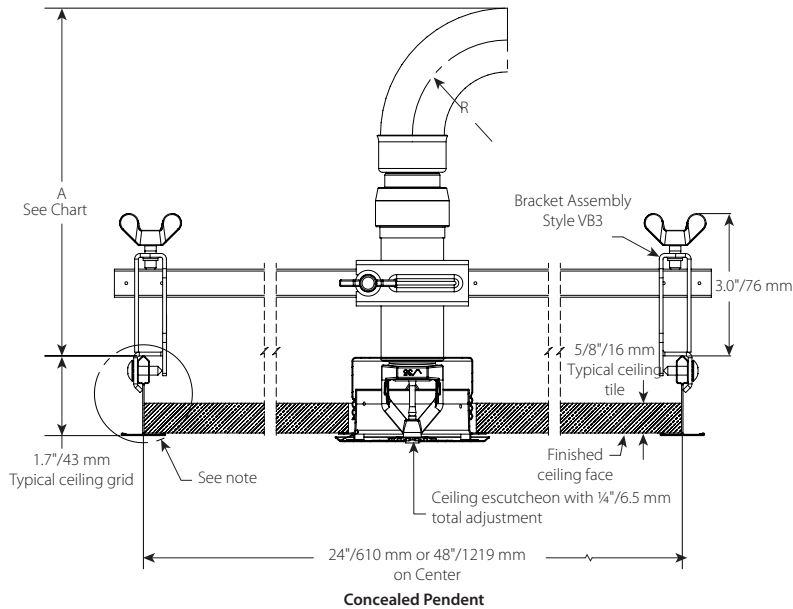

Clearance Chart		
Dimension	inches mm	
"R" Minimum Bend Radius	2	7
	50	175
"A" Minimum Required Installation Space	7¾	12¾
	193	320

**NOTE**

- Victaulic *VicFlex* Style VB3 Bracket assemblies shall be used only with Style VS1 concealed pendant sprinklers.

## 4.11 DIMENSIONS

### VB4 Sleeve and Skirt Pendant

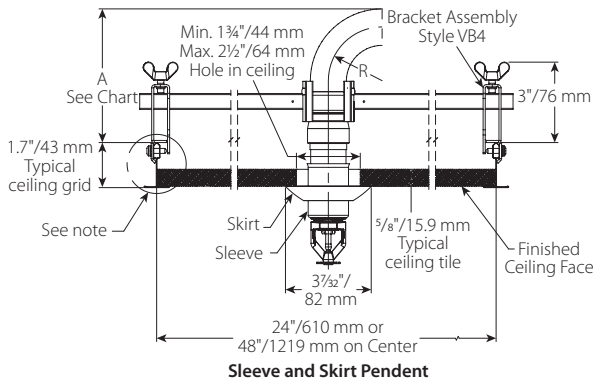

Clearance Chart		
Bend Radius		
	inches mm	inches mm
"R" Minimum Bend Radius	2 51	7 178
"A" Minimum Required Installation Space	5 127	10 254

**NOTE**

- Victaulic *VicFlex* Style VB2 Bracket assemblies shall be used only with Style VS1 recessed pendant sprinklers.

## 5.0 PERFORMANCE

### Freeze Protection

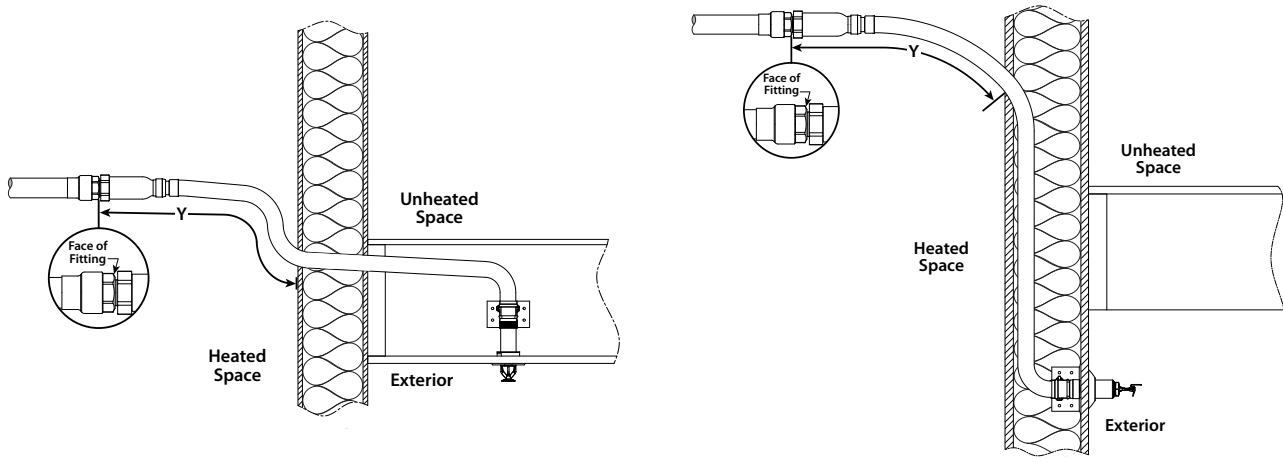

Ambient Temperature Exposed to Discharge End of Sprinkler	Exposed Minimum Barrel Length "Y"		
	inches mm		
	40°F/4°C	50°F/10°C	60°F/16°C
40 °F	0	0	0
4 °C	0	0	0
30 °F	0	0	0
-1 °C	0	0	0
20 °F	4	0	0
-7 °C	100	0	0
10 °F	8	1	0
-12 °C	200	25	0
0 °F	12	3	0
-18 °C	300	75	0
-10 °F	14	4	1
-23 °C	350	100	25
-20 °F	14	6	3
-29 °C	350	150	75
-30 °F	16	8	4
-34 °C	400	200	100
-40 °F	18	8	4
-40 °C	450	200	100
-50 °F	20	10	6
-46 °C	500	250	150
-60 °F	20	10	6
-51 °C	500	250	150

**NOTE**

- Exposed minimum barrel lengths are inclusive up to 30-mph/48-kph wind velocities.

### Maximum Allowable Number of Bends

Sprinkler Length inches mm	Maximum Allowable Number of 90° Bends at 2"/51mm Bend Radius for UL Listing	Maximum Allowable Number of 90° Bends at 7"/178mm Bend Radius for FM Approval
38 965	4	2
50 1270	4	3
58 1475	4	4



## 6.0 NOTIFICATIONS

### WARNING



- Read and understand all instructions before attempting to install any Victaulic products.
- Always verify that the piping system has been completely depressurized and drained immediately prior to installation, removal, adjustment, or maintenance of any Victaulic products.
- Wear safety glasses, hardhat, and foot protection.

- These products shall be used only in fire protection systems that are designed and installed in accordance with current, applicable National Fire Protection Association (NFPA 13, 13D, 13R, etc.) standards, or equivalent standards, and in accordance with applicable building and fire codes. These standards and codes contain important information regarding protection of systems from freezing temperatures, corrosion, mechanical damage, etc.
- The installer shall understand the use of this product and why it was specified for the particular application.
- The installer shall understand common industry safety standards and potential consequences of improper product installation.

### WARNING

- It is the responsibility of the system designer to verify suitability of 300-series stainless steel flexible hose for use with the intended fluid media within the piping system and external environments.
- The effect of chemical composition, pH level, operating temperature, chloride level, oxygen level, and flow rate on 300-series stainless steel flexible hose must be evaluated by the material specifier to confirm system life will be acceptable for the intended service.
- It is the responsibility of the owner of a building or their authorized agent to provide the sprinkler system installer with any knowledge that the water supply might be contaminated with or conducive to the development of microbiologically influenced corrosion (MIC), including as required by NFPA 13. Failure to identify adverse water quality issues may affect the VicFlex product and void the manufacturer's warranty.

**Failure to follow these instructions could cause product failure, resulting in serious personal injury and/or property damage.**

DO NOT paint, coat, or firestop the outlet/inlet portion of the Style VS1 Dry Sprinkler. Braided hose and fitting portions of the Style VS1 Dry Sprinkler may be painted or coated, provided that the paint or coating is compatible with stainless steel material. This includes penetration through firestop-filled annular space of a firewall. The firestop material in direct contact with the flexible braided hose will not impede functionality of the Style VS1 Dry Sprinkler, provided that the components are installed in accordance with Victaulic's installation instructions.

## 6.0 NOTIFICATIONS (CONTINUED)

### Important Installation Notes:

1. Shall be installed only in accordance with NFPA 13 Standard for the the Installation of Sprinkler Systems and applicable FM Data Sheets.
2. Install and tighten swivel hex nut at inlet of sprinkler fitting only.
3. Do not remove deflector or inlet end of sprinkler.

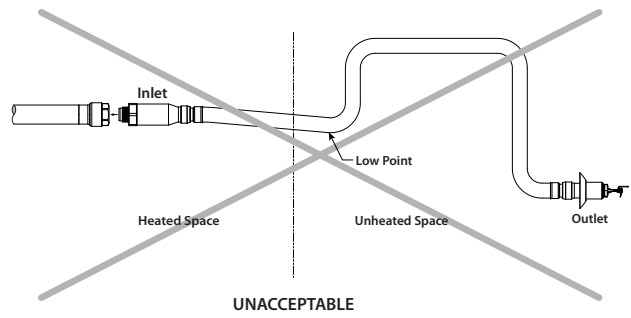
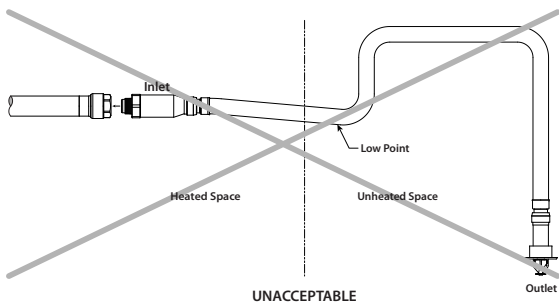
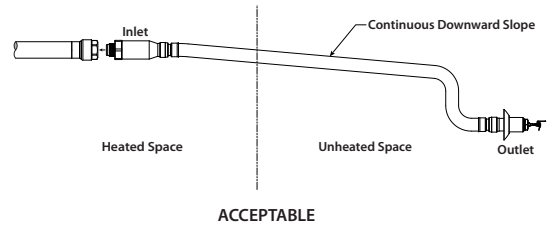
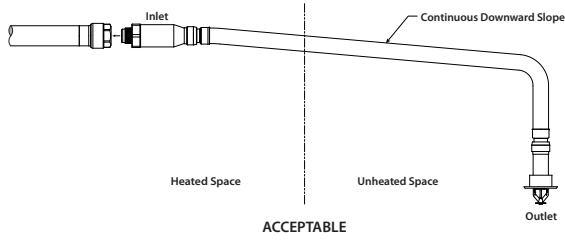

## 6.0 NOTIFICATIONS (CONTINUED)

### FOR DRY SYSTEMS ONLY:

- The Style VS1 Dry Sprinkler's inlet shall be installed only into the outlet of a fitting (excluding elbows) or welded outlet that meets the dimensional requirements of ANSI B16.3 and ANSI B16.4, Class 125 and Class 150. Use a sample fitting to confirm proper engagement and to verify that there is no interference between the sprinkler and the fitting.

**Style VS1 Dry Sprinklers in an unheated space shall be installed with a continuous downward slope along its entire length from the branch line fitting to the sprinkler. No localized low points shall be present along the length of the Style VS1 Dry Sprinkler.**

**Style VS1 Dry Sprinklers in an unheated space are not permitted to be installed into the top of the branch line piping. Style VS1 Dry Sprinklers shall be installed into the side or from the bottom of the branch line piping.**

**In a heated space, if a portion of the Style VS1 Dry Sprinkler is installed from the top of a branch line and then extends into an unheated space, it shall be installed with a continuous downward slope along the entire length from the inside wall to the outlet of the sprinkler. No localized low points shall be present along the length of the sprinkler in the unheated space. Refer to the drawing below.**

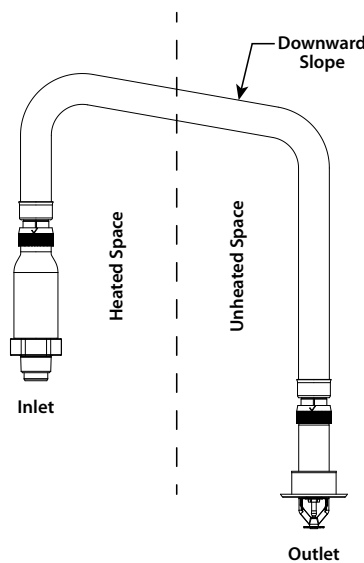

### FOR WET SYSTEMS ONLY:

- **DO NOT** install Victaulic® VicFlex™ Style VS1 Dry Sprinklers into any threaded elbow, threaded-by-thread coupling, or fitting that interferes with thread penetration. The inlet of the Victaulic® VicFlex™ Style VS1 Dry Sprinkler **SHALL NOT** bottom out in the fitting. Use a sample fitting to confirm proper engagement.
- To ensure unobstructed flow during operation, the Victaulic® VicFlex™ Style VS1 Dry Sprinkler shall be installed into a fitting that will prevent water and debris from accumulating at the dry sprinkler's inlet.
- Verify that the exposed minimum barrel length in the heated space is measured and maintained in accordance with the table on page 1.

**In a heated space, if a portion of the Style VS1 Dry Sprinkler extends into an unheated space, it shall be installed with a continuous downward slope along the entire length from the inside wall to the outlet end of the dry sprinkler. No localized low points shall be present along the length of the sprinkler in the unheated space. Refer to the drawing above.**

## 7.0 REFERENCE MATERIALS

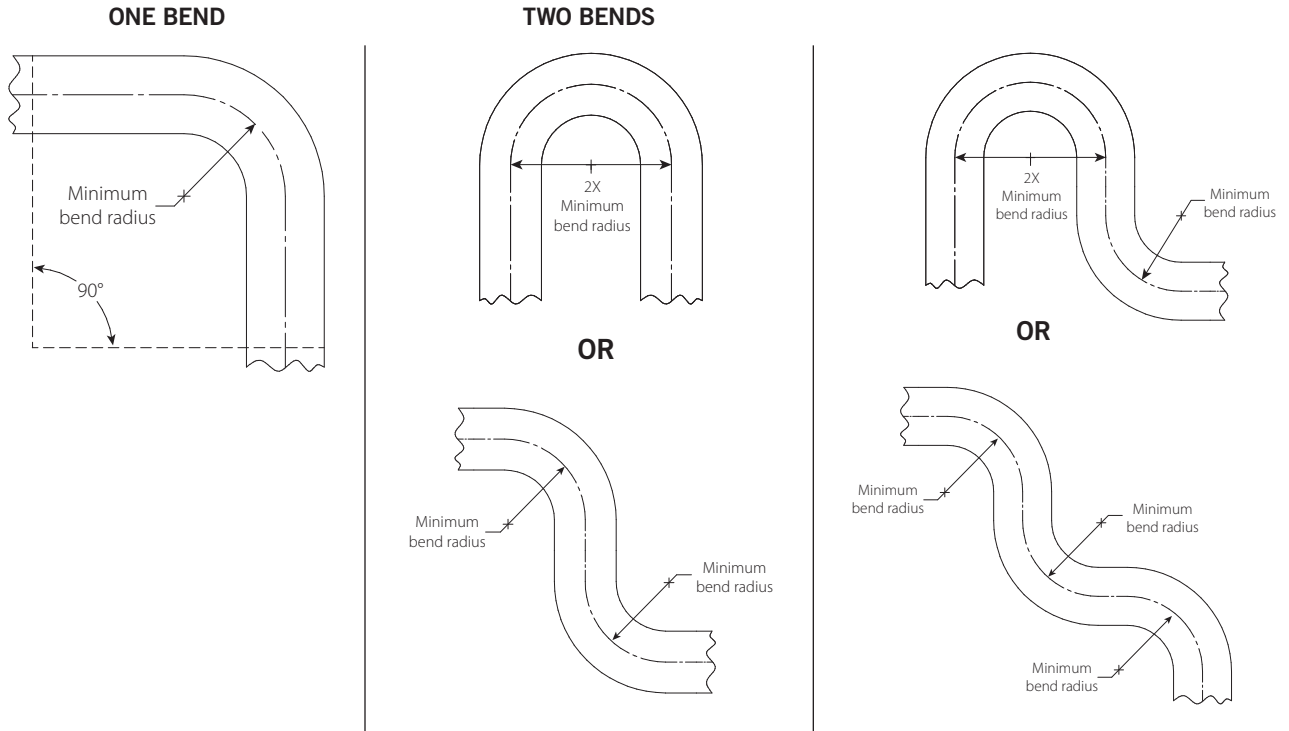

**NOTE**

For out-of-plane (three-dimensional) bends, care must be taken to avoid imparting torsional stress on the sprinkler.

7.0 REFERENCE MATERIALS

Order No.	Date
Company Name	
Address	
State/Province	
Zip Code/Postal Code	
Tag	

Ship To:

Company Name	
Address	
State/Province	Zip Code/Postal Code
Phone No.	Email
Fax No.	

Quantity (as specified below):  If units of different size, type or other option are required, please attach additional form(s) with their specification(s) separately.

**VicFlex™ Dry Sprinkler Model VS1**

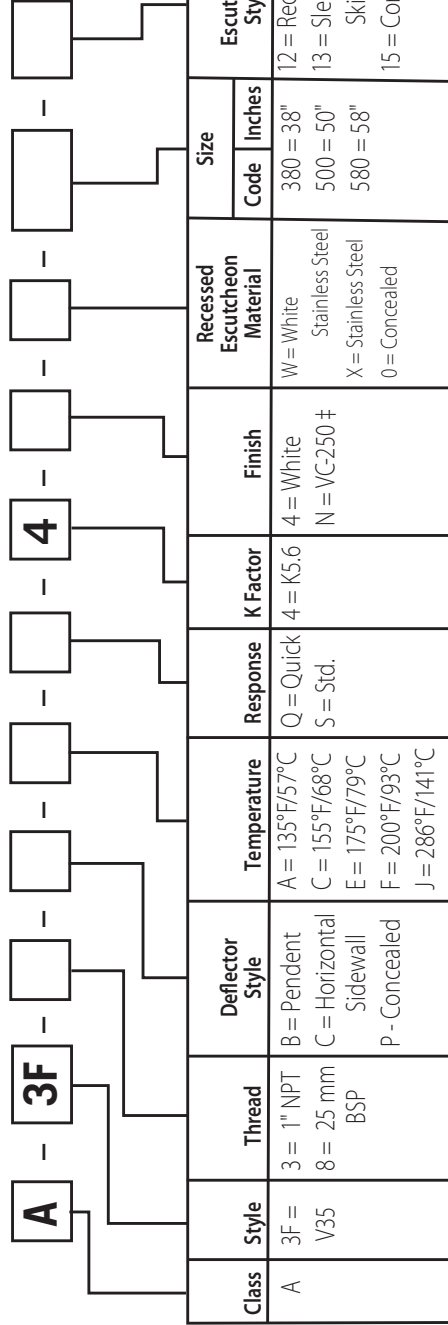

‡ VC-250 sprinkler finish sold standard on the VicFlex Dry Sprinkler Model VS1.

---

## 7.0 REFERENCE MATERIALS (CONTINUED)

---

[29.01: Victaulic Terms and Conditions of Sale](#)

[I-VICFLEX.VS1: Victaulic® VicFlex™ Style VS1 Dry Sprinkler Installation Instructions](#)

---

### User Responsibility for Product Selection and Suitability

Each user bears final responsibility for making a determination as to the suitability of Victaulic products for a particular end-use application, in accordance with industry standards and project specifications, and the applicable building codes and related regulations as well as Victaulic performance, maintenance, safety, and warning instructions. Nothing in this or any other document, nor any verbal recommendation, advice, or opinion from any Victaulic employee, shall be deemed to alter, vary, supersede, or waive any provision of Victaulic Company's standard conditions of sale, installation guide, or this disclaimer.

### Intellectual Property Rights

No statement contained herein concerning a possible or suggested use of any material, product, service, or design is intended, or should be construed, to grant any license under any patent or other intellectual property right of Victaulic or any of its subsidiaries or affiliates covering such use or design, or as a recommendation for the use of such material, product, service, or design in the infringement of any patent or other intellectual property right. The terms "Patented" or "Patent Pending" refer to design or utility patents or patent applications for articles and/or methods of use in the United States and/or other countries.

### Note

This product shall be manufactured by Victaulic or to Victaulic specifications. All products to be installed in accordance with current Victaulic installation/assembly instructions. Victaulic reserves the right to change product specifications, designs and standard equipment without notice and without incurring obligations.

### Installation

Reference should always be made to the Victaulic installation handbook or installation instructions of the product you are installing. Handbooks are included with each shipment of Victaulic products, providing complete installation and assembly data, and are available in PDF format on our website at [www.victaulic.com](http://www.victaulic.com).

### Warranty

Refer to the Warranty section of the current Price List or contact Victaulic for details.

### Trademarks

*Victaulic* and all other Victaulic marks are the trademarks or registered trademarks of Victaulic Company, and/or its affiliated entities, in the U.S. and/or other countries.



Moldovan, Florin &lt;florin.moldovan@dhcd.virginia.gov&gt;

---

## Loudoun County Townhomes with Residential Sprinklers

6 messages

---

**Johnson, Keith** <Keith.Johnson@loudoun.gov>  
To: Florin Moldovan <florin.moldovan@dhcd.virginia.gov>  
Cc: jimmy csizmadia <Jcsizmadia@pwcgov.org>

Sun, Feb 20, 2022 at 8:58 AM

Hi Florin,

See the email below regarding pricing for Townhome sprinkler costs. This is in addition to what Jimmy send.

Keith

Keith H. Johnson

System Chief

Loudoun County Combined Fire and Rescue System

Office: 703-777-0435

Cell: 571-465-0119

Email: [Keith.Johnson@loudoun.gov](mailto:Keith.Johnson@loudoun.gov)

*Teamwork \* Integrity \* Professionalism \* Service*

---

**From:** Barry, Chris <[Chris.Barry@loudoun.gov](mailto:Chris.Barry@loudoun.gov)>  
**Sent:** Tuesday, February 15, 2022 3:42 PM  
**To:** Johnson, Keith <[Keith.Johnson@loudoun.gov](mailto:Keith.Johnson@loudoun.gov)>; Sundberg, Leif <[Leif.Sundberg@loudoun.gov](mailto:Leif.Sundberg@loudoun.gov)>  
**Cc:** Kiger, Micah <[Micah.Kiger@loudoun.gov](mailto:Micah.Kiger@loudoun.gov)>  
**Subject:** RE: Loudoun County Townhomes with Residential Sprinklers

Chief, I tracked down a residential sprinkler estimator from Nobel Fire Protection in Maryland their company installed many of the sprinklers in the Brambleton active adult community. He advised the project I was inquiring about with 30 heads would cost approximately \$3k and the permit fee per unit would be \$70 and PE stamp would be approximately \$150. He advised with Loudoun water they can use a single line to the meter where it is split for fire protection. He advised with those situations there is typically no other costs to the system. He did advise if you wanted to reach out directly with him we would be more than willing to help with any other questions. His name is Herb Stoltz 814-889-9929. If you need anything else please let me know.

# Virginia Townhouse Sprinkler Price Survey

Compiled by Jeffrey Shapiro, P.E., FSFPE, IRC Fire Sprinkler Coalition 12/7/2020

The information below has been provided by two sprinkler contractors who were asked to provide Virginia-specific price histories for townhouse projects built in Virginia in the past few years. These are the prices charged to builders, exclude any builder markup that might increase the actual cost to consumers, and exclude permit fees that may be charged in addition to the base building permit cost.

## Response from Contractor 1

- The following data reflects costs for 10 projects constructed between 2016 and 2019. Prices do not include added costs associated with local amendments exceeding what is required by the nationally recognized standard.

Job Location	Year	Cost per Unit	Average Cost Per Square Foot
Reston, VA	2019	\$2,050.00	\$1.33
Reston, VA	2017	\$2,045.00	\$1.27
Reston, VA	2017	\$1,800.00	\$1.17
Haymarket, VA	2016	\$2,762.00	\$1.25
Haymarket, VA	2016	\$2,490.00	\$1.13
Haymarket, VA	2016	\$2,350.00	\$1.16
Leesburg, VA	2020	\$3,525.00	\$1.21
Leesburg, VA	2020	\$3,250.00	\$1.25
Alexandria, VA	2019	\$4,900.00	\$1.48
Alexandria, VA	2019	\$5,000.00	\$1.41

- **Fairfax County average price is \$1.26 per square foot (NFPA 13D).**
- **Prince William County average price is \$1.18 per square foot (NFPA 13D).**
- **Loudon County average price is \$1.23 per square foot (NFPA 13D).**
- **Arlington County average price is \$1.31 per square foot (NFPA 13D).**

## Response from Contractor 2

- **Loudoun County average price is \$1.71 per square foot (NFPA 13R).**
  - \$1.71 figure represents the average price for over 500 units constructed by four different builders in the past five years.
  - Loudoun permits a modified NFPA 13R design, that does not require a fire department connection and permits a design based on 2 sprinklers operating, rather than 4, which is ordinarily required under NFPA 13R.
- **Fairfax County average price is \$1.86 per square foot (NFPA 13R)**
  - The \$1.86 figure represents the average price for 220 units constructed by three different builders in the past four years

Costs provided by this contractor exceed what would be expected to comply with the proposed Virginia Residential Code because the costs reflect systems that were designed to the NFPA 13R standard, not the NFPA 13D standard, which the residential code will permit. NFPA 13R systems are typically used to protect large residential complexes and are more expensive than NFPA 13D systems, which are for protection of townhouses and one- and two-family dwellings.

**The table and figure on the following page summarize all results**



<b>Fairfax County</b>	<b>NFPA 13D</b>	<b>\$1.26</b>
<b>Fairfax County</b>	<b>NFPA 13R</b>	<b>\$1.86</b>
<b>Prince William County</b>	<b>NFPA 13D</b>	<b>\$1.18</b>
<b>Loudon County</b>	<b>NFPA 13D</b>	<b>\$1.23</b>
<b>Loudon County</b>	<b>NFPA 13R</b>	<b>\$1.71</b>
<b>Arlington County</b>	<b>NFPA 13D</b>	<b>\$1.31</b>

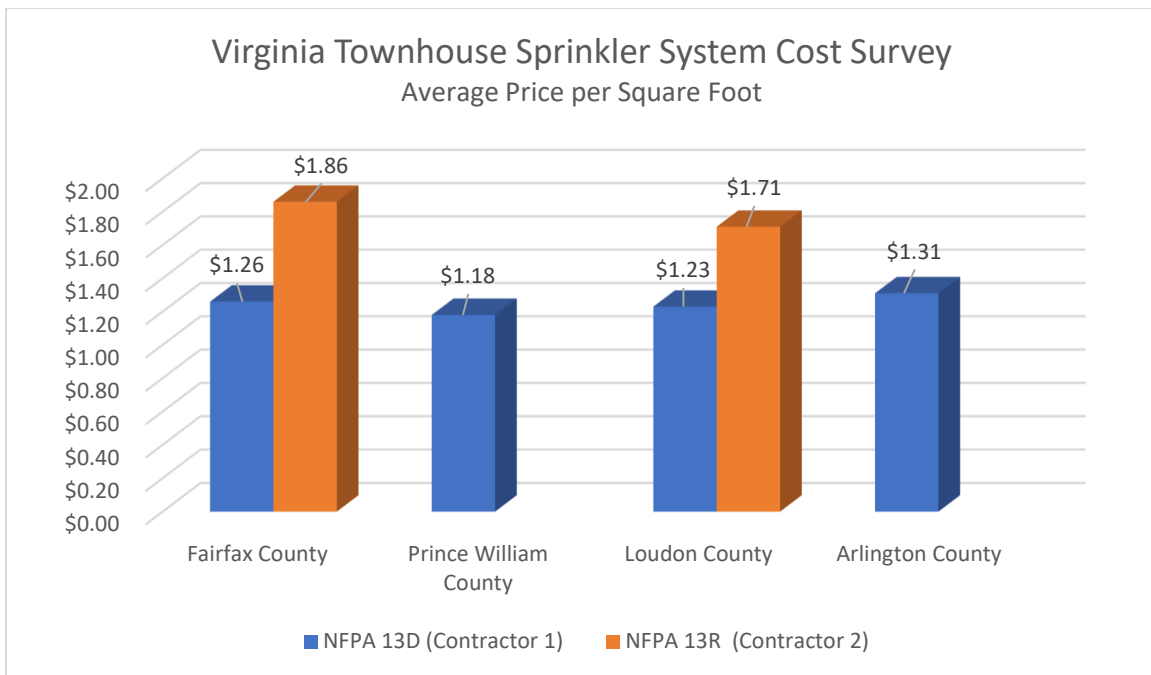

**Submitted By:**

Andrew Clark  
Vice President of Government Affairs  
Home Builders Association of Virginia

**Access to Virginia-Specific Fire Data is Lacking:**

All stakeholders should have equal access to data related to residential home fire incidents, deaths, injuries, causes, and other relevant information. Currently, the US Fire Administration dashboard contains informative, but surface level, data regarding the fire casualties by incident type, residential structure fire casualties, and a handful of other data points. However, there is a dearth of publicly available, substantive, and comprehensive data that would inform stakeholders about residential home fire trends in Virginia. According to their website, the US Fire Administration annually collects data from 24,112 fire departments across the country – however, that data is only available by 1) ordering a “CD or DVD” – free of charge. Some stakeholders have the option to download the data from the USFA website – however, the information is provided in countless raw data files that require a “...database management system and expertise in SQL and/or other database programming language” to access<sup>1</sup>. The USFA also has a disclaimer that the database is for “researchers and fire data analysts” and that users “should have considerable experience with fire data analysis and NFIRS data to properly use the PDR”.

I understand that this is a complex data set with 24,000 fire departments inputting a lot of data set – but there is little-to-no ability for non-fire data analysts to dive into the numbers, aside from the relatively high-level reports published by the NFPA. Additionally, unless I’m missing something, the NFPA does not make publicly available any reports specific to Virginia – it’s all national-level data.

I have also attempted to find more Virginia-specific data on the Virginia Department of Fire Programs (VD FP) website – my assumption being that USFA and NFPA focus on national data, leaving the state-level data to VD FP to analyze and publish. There are currently several pages on VD FP’s website devoted to data:

**Fire and Data Statistics:** <https://www.vafire.com/fire-and-data-statistics-2/> - There is a high-level chart which summarizes incidents between 2013-2018. However, the summary data has not been updated since 2018 – and there is little information that would be relevant to the discussion of townhome fire sprinklers. There also appears to be more substantive reports re: residential structure fire causes, incident types, etc – but those reports stopped being published on the VD FP website in 2015. And currently, there are only reports for 2013, 2014, and 2015.

**VFIRS Facts and Figures:** <https://www.vafire.com/vfirs-facts-and-figures/> - Same as above – this page contains high-level information.

**VFIRS Annual Reports:** <https://www.vafire.com/vfirs-annual-reports/> - The annual reports are probably the most substantive data set on the VD FP website, but the annual reports stopped being published in 2014. To the VD FP’s credit, they have uploaded the annual reports for every

---

<sup>1</sup> USFA Website – NFIRS Data Download: <https://www.usfa.fema.gov/nfirs/order/>

year between 2007 to 2014, but there is no ability to look at all of this data over time, unless someone is willing to aggregate every data point from each report into a single spreadsheet.

As stated on the USFA's website, the purpose of having fire departments contribute to NFIRS is to:

- Analyze the severity and reach of the nation's fire problem.
- Use NFIRS information to develop national public education campaigns.
- Make recommendations for national codes and standards.
- Determine consumer product failures.
- Identify the focus for research efforts.
- Support federal legislation.

I imagine that the purpose of the VFIRS data is similar, if not identical. However, in its current "lock box form" where very few people can actually access it, it is extremely difficult to see how fire services representatives, local governments, legislators, or stakeholders can actually utilize that data to accomplish any of the goals mentioned above.

Again – I understand that this is an incredibly complex data set that probably requires a significant investment of time and resources by VDFP staff to collect, analyze, and publish. I also understand that the VDFP may not have the staff or resources available to undertake that endeavor – if that is the case, there should be a concerted effort by the stakeholders to advocate for a significant increase in state financial resources so that the VDFP can publish the data that would benefit local and state elected officials, local and state government staff, fire departments, and others.

### **Virginia-Specific Data is Needed to Inform Discussion re: Fire Sprinklers**

The decision to require residential fire sprinkler systems in townhomes or single-family structures is a significant public policy decision that would have a direct impact on the cost of housing in Virginia. Although some stakeholders will debate the actual cost of the proposal, the very low number of states that have adopted some form of the requirement reflects the substantial nature of the public policy decision to require or not require residential fire sprinklers.

Given the impact that this proposal would have on the cost of housing – at a time where the housing affordability crisis is a top priority for local and state officials – this code proposal should not be adopted without a thorough review of Virginia-specific fire data – that level of review would allow the stakeholders and the Board of Housing and Community Development the opportunity to weigh the costs of potentially exclusionary market requirements against the public health benefits of raising the baseline standard of all new townhomes – and furthermore, would allow the stakeholders to determine whether a similar public safety benefit could be accomplished through a more cost-effective means for consumers.

Phrased differently – The stakeholders and the Board deserve the opportunity to evaluate Virginia-specific data to determine if, as some stakeholders claim, new homes are actually more susceptible to fires – or if the predominant number of residential fires (and death/injury resulting from a residential fire) are actually occurring in older structures built to a lesser standard. If the data demonstrates that the majority of residential home fires are occurring in older existing structures - or structures where smoke alarms are not installed or outdated/removed - we should focus our efforts on reducing/mitigating that risk by increasing consumer education about the importance of smoke alarms,

establishing more “touch points” between fire services and renters/homeowners in areas known to be at a greater risk of home fires, and ensuring that localities and local fire departments have the resources they need to test and install modern smoke alarm technology in those structures, free of cost to the resident or tenant.

There is a large body of evidence which demonstrates that the proliferation of smoke alarms in residential structures has saved lives with virtually zero impact to the cost of housing for consumers – reports from both NFPA, NAHB, and third parties substantiate this claim. Similarly, advancements in smoke alarm technology have virtually eliminated the possibility of the battery being removed to power other electronic devices or to “stop the beeping” when a battery is running low – and as a result, has further reduced the number of fatalities in residential home fires. However, according to data that has been released by the NFPA, 41% of the home fire deaths were caused by fires in properties **with no smoke alarms**<sup>2</sup>. Furthermore, an additional 16% of home fire deaths occurred in properties where the smoke alarm failed to operate. Smoke alarms are a proven, cost-effective means of increasing public safety in residential structures – and the national data from the NFPA shows that there are still a large number of homes that are under-protected or unprotected.

The purpose of the Virginia Uniform Statewide Building Code is to establish a baseline standard of safety, quality, and efficiency in new residential structures. All residents deserve to be safe and secure in their homes or apartments – and the data shows that advancements in building codes coupled with the homebuilding industry’s response to consumer expectations have contributed to safer structures. However, not all homebuyers or renters can afford the additional costs of a residential fire sprinkler system – and the proposal to require these systems in all new townhomes would disproportionately impact individuals and families in the lower to middle end of the income spectrum.

---

<sup>2</sup> NFPA Smoke Alarm Report (2021): <https://www.nfpa.org/-/media/Files/News-and-Research/Fire-statistics-and-reports/Detection-and-signaling/ossmokealarms.pdf>

## Richmond Region Builder

### Direct/Tangible costs:

1. Cost to install system within each unit – \$2.55-\$2.75/sq. feet
  - a. 2,015 sq. feet townhome would be \$5,125.50 to \$5,541.25
2. Infrastructure cost – 6” dedicated waterline for fire sprinkler distribution – very dependent on density and efficiency of layout - \$2,100/townhome minimum. We are fairly dense and efficiently configured. This number could easily double or worse depending on the site constraints.

### Intangible costs – these items add cost, but difficult to determine specific dollar amount.

1. Sitework prolonged: Fire line and domestic water line are not installed in the same trench. Increased exposure to weather, damage etc. due to added installation of materials and installation means and methods.
2. Vertical construction prolonged: Adds an additional trade to the construction process, adds firestopping complexity, insulation complexity and increases the number of inspections required to obtain a certificate of occupancy.
3. If static pressure of surrounding waterlines is insufficient booster pumps will be required to maintain minimum pressures on the upper levels of the home. Booster pump requires the construction of a heated, weather proof enclosure, power supply, and meter; **adding a minimum cost \$20,000 if required**. This has happened in several of our projects in the Richmond Region.
4. Damage to system during construction creates catastrophic losses, usually passed on to insurance, raising premiums which then get passed on to future purchasers. This has also occurred at several of our properties.
5. Damages/failures after occupancy, creates catastrophic losses to homeowner and potentially neighboring homes and personal property. This has also happened at several properties.

### Additional Notes:

- I’ve included sprinklers in several of our projects in the area – and can say that it certainly adds cost to the units – which is fine for us/the builder – but it does have the effect of shifting the price point of the units up, which means a different set a buyers are moving in. Units that may have been in line with “market rate” become above-market rate – and in some cases, they become “luxury units”.
- We have noticed that several potential buyers have been uncomfortable about moving into a unit that has sprinklers in it – these have typically been consumers that have done some research and found stories about sprinklers going off when there isn’t a fire, etc; in some of the larger townhome units, we’ve had some people concerned about their kids and their friends throwing toys at the sprinkler heads. The other frequent question that we get is if a homeowner has the ability to turn off the sprinkler after its been activated. We try to educate the potential buyer but are not always successful.
- Backflow Testing – we get questions about whether localities require annual inspection and if so, how expensive it is
- Longevity of the equipment – Most people live in their townhome for maybe 5-7 years; some go longer. But we have received questions about how long the infrastructure lasts and whether it will need to be replaced or updated after 5 years or so.

**Stand Alone System - Public Water Supply**

Item	Cost	Notes
Additional tap fees	\$ 5,600.00	Cost of permit and tap of 1" non-metered water supply - per TOB Public Works Dept.
Exterior ditching and water pipe	\$ 1,450.00	Secondary waterline install to the dwelling - established cost of water line install
Additional backflow preventer	\$ 500.00	Backflow preventer and shutoff for sprinkler supply line
Sprinkler System Rough-In	\$ 10,000.00	Piping, pressure testing, sprinkler heads, etc. - estimation by Fire Protection Services
Water flow alarm	\$ 400.00	Reporting alarm system triggered by water flow - average from market research
Additional attic frost protection	\$ 1,200.00	Water line encapsulation and crush protection in freezing area
Drain for water supply	\$ 200.00	Cost for hub drain at point of supply
	<b>\$ 19,350.00</b>	

**Multi-Purpose System - Public Water Supply**

Item	Cost	Notes
Additional tap fees	\$ 6,960.00	Cost 1" water supply minus cost of standard 5/8" water meter - per TOB Public Works Dept.
Larger backflow preventer	\$ 300.00	2" Backflow preventer and shutoff for multi-purpose system
Sprinkler System Rough-In	\$ 10,000.00	Piping, pressure testing, sprinkler heads, etc.
Water flow alarm	\$ 400.00	Reporting alarm system triggered by water flow
Additional attic frost protection	\$ 1,200.00	Water line encapsulation and crush protection in freezing area
Drain for water supply	\$ 200.00	Cost for hub drain at point of supply
	<b>\$ 19,060.00</b>	

**Private Water Supply - Costs are similar for both installation types**

Item	Cost	Notes
Underground water storage	\$ 4,200.00	Cost of cistern storage tank (1200 gallons), pump, and installation
Sprinkler System Rough-In	\$ 10,000.00	Piping, pressure testing, sprinkler heads, etc.
Water flow alarm	\$ 400.00	Reporting alarm system triggered by water flow
Additional attic frost protection	\$ 1,200.00	Water line encapsulation and crush protection in freezing area
Back up power supply	\$ 6,000.00	Power to pump
Drain for water supply	\$ 200.00	Cost for hub drain at point of supply
	<b>\$ 22,000.00</b>	

## **Overview from Home Builders Association of Virginia:**

The purpose of the Virginia Uniform Statewide Building Code is to establish a baseline standard of safety, quality, and efficiency in new residential structures. Proposed building codes should not be rejected outright because there may be associated costs, however, the Board of Housing and Community Development must weigh the effects of potentially exclusionary market requirements on the supply and access to housing for households across the income spectrum; and furthermore, identify other code requirements that may accomplish an identical public safety benefit through less exclusionary means.

Proponents of the proposal to mandate fire sprinkler systems in new single-family homes and townhomes have discounted concerns raised by the housing industry and other stakeholders regarding the proposal's impact on housing affordability and housing accessibility in Virginia. The housing crisis, both nationally and in Virginia, is well documented and has been identified as a top policy priority for state and local elected officials.

The Home Builders Association of Virginia has compiled several reports/studies regarding the housing affordability challenges in the Commonwealth and ask that the study group and the Board of Housing and Community Development consider this information while discussing the code proposal.

- Joint Legislative Audit and Review Committee (JLARC) Report: Affordable Housing in Virginia (December 2021)
- Metropolitan Washington Council of Governments: The Future of Housing in Greater Washington
- Virginia Housing Policy Advisory Council: Addressing the Impact of Housing for Virginia's Economy (November 2017)
- National Low Income Housing Coalition – Out of Reach Report, Virginia (2021)
- National Association of Home Builders – Priced Out Report (2022)

### ***Joint Legislative Audit and Review Committee Report: Affordable Housing in Virginia***

The Joint Legislative Audit and Review Commission (JLARC) conducts program evaluation, policy analysis, and oversight of state agencies on behalf of the Virginia General Assembly. In 2020, the Joint Legislative Audit and Review Commission (JLARC) directed staff to “conduct a review of affordable housing in Virginia. JLARC staff were asked to report on the “number of Virginia households that are housing cost burdened; the supply of affordable quality housing statewide and by region; the state's efforts to increase the supply of affordable housing and make existing housing more affordable through direct financial assistance; and the effectiveness of the management of the state's housing assistance programs.”<sup>1</sup>

The report, which was released in December 2021, is a comprehensive analysis of the housing market in Virginia and, over the course of its 200 pages, refutes any claims that housing affordability is not a dire crisis and challenge for localities and regions across the Commonwealth.

#### *Summary of Report's Findings:*

- “Approximately 29 percent of Virginia households (905,000) were housing cost burdened in 2019, and nearly half of these households spent more than 50 percent of their income on housing. Virginia

---

<sup>1</sup> JLARC Report: Affordable Housing in Virginia: <http://jlarc.virginia.gov/landing-2021-affordable-housing-in-virginia.asp>

ranks near the middle of states in terms of the percentage of households that are cost burdened.”  
[\(JLARC Report: PDF Page 5\)](#)

- “Households are considered housing cost burdened when they spend more than 30 percent of their income on housing expenses. Housing cost burden constrains households’ budgets, making it difficult for households to afford other necessities and making eviction more likely.” [\(JLARC Report: PDF Page 5\)](#)
- Every region of the Commonwealth has a high percentage of households who are cost-burdened – see chart on next page

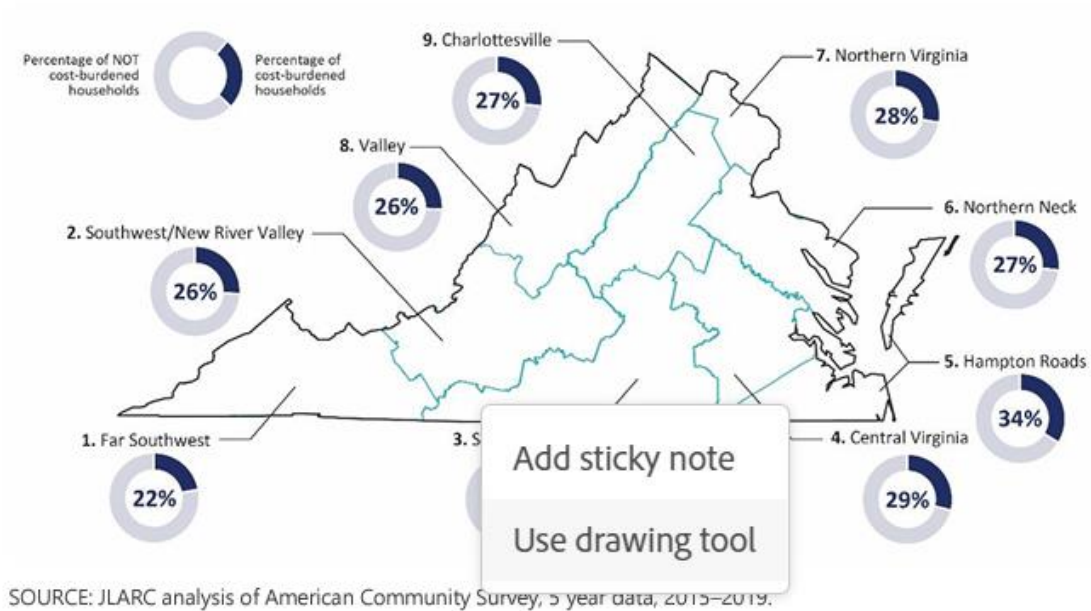

- The Percentage of Cost Burdened Low-Income Households is Growing:
  - While the proportion and number of Virginia households that are cost burdened declined between 2009 and 2019, the prevalence of housing cost burden among low-income Virginians increased slightly from 60 percent to 63 percent over this period (Figure 2-6). This affects Virginians who work in common occupations that are essential to the state’s economy and are paid low wages. For example, the median income for a home health aide in Virginia is approximately \$22,000, which is considered very low income for a single person household (income between 31 and 50 percent AMI) (Figure 2-7). In another example, the median income for a bus driver is \$45,000, which is considered low income for a single person household (income between 51 and 80 percent AMI). [\(JLARC Report: PDF Page 35\)](#)

**FIGURE 2-6**  
**Percentage of cost burdened households grew among lower income households, 2009–2019**

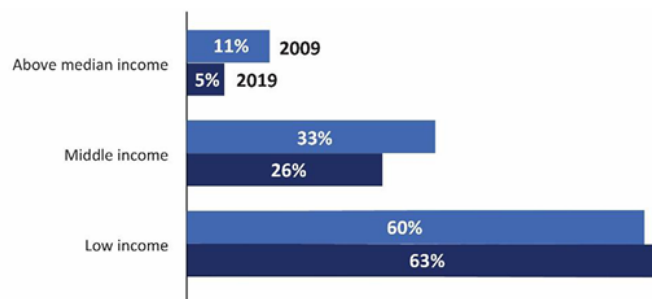

SOURCE: JLARC analysis of American Community Survey, 5 year data, 2005–2009 and 2015–2019.  
 NOTE: All figures are rounded to the nearest 1,000. Figures may not add because of rounding. Low income includes



- “Declining number of Virginians can afford to buy a home, and state has a shortage of at least 200,000 affordable rental units” ([JLARC Report: PDF Page 5](#))
  - “Rising home prices have made it more difficult for Virginians to own their homes. The median home sales price in Virginia has risen 28 percent over the past four years to \$270,000 in 2021. Virginia’s stock of homes that would be affordable to low- and middle-income households has declined substantially in the past few years.”
  - “Low- and middle-income households may have incomes that could support mortgage payments but lack the savings to cover the upfront costs of purchasing a home. Rising home prices mean that down payments and closing costs can be over \$10,000 on even moderately priced homes.” ([JLARC Report: PDF Page 6](#))
- Shortage of Affordable Units is Statewide – Every Region Needs AT LEAST 6,000 new affordable units
  - Virginia has a statewide shortage of at least 200,000 affordable rental units for extremely and very low income households. Only 42 out of every 100 extremely and very low income households can find affordable housing. The actual number of needed affordable rental units likely exceeds 200,000 because this figure is based on data from several years ago and assumptions about the most affordable units that can be created through programs like the federal Low Income Housing Tax Credit pro-gram (LIHTC) ([JLARC Report: PDF Page 38](#))

**FIGURE 2-8**  
**Majority of affordable rental units are needed in Urban Crescent**

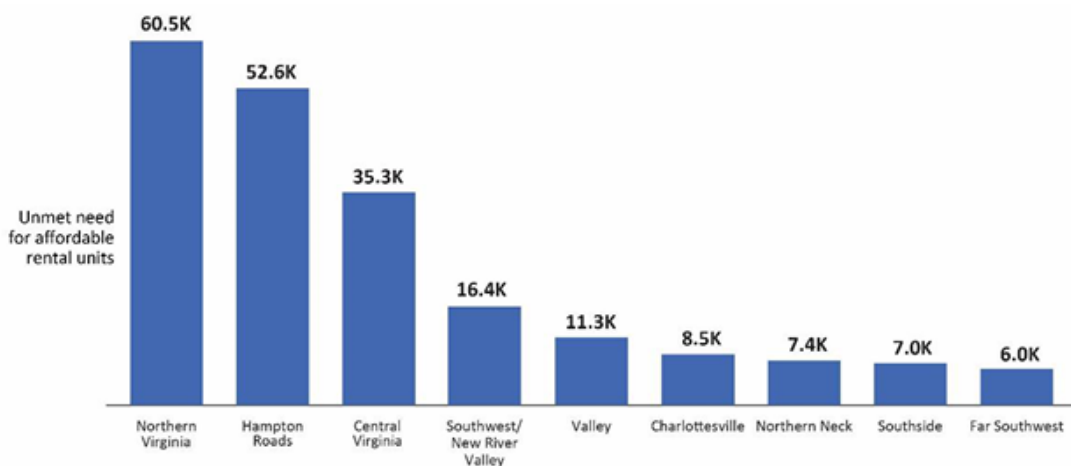

SOURCE: JLARC analysis of American Community Survey, 5 year data, 2015–2019.  
 NOTE: All figures are rounded to the nearest 100. Figures may not add because of rounding.

- Median Home Sales Prices Have Risen Significantly between 2016-2021, 2020-2021

**TABLE 2-4**

Median home sales prices increased substantially, and especially rapidly in the past year

	Median home sales prices			Percentage change	
	2016	2020	2021	2016 to 2021	2020 to 2021
<b>Northern Virginia</b>	\$508,000	\$582,000	\$650,000	28%	12%
<b>Charlottesville</b>	290,000	319,000	350,000	21	10
<b>Hampton Roads</b>	254,000	234,000	330,000	30	41
<b>Northern Neck</b>	267,000	270,000	325,000	22	20
<b>Central Virginia</b>	210,000	257,000	299,000	42	16
<b>Valley</b>	233,000	241,000	285,000	22	18
<b>Southwest/New River Valley</b>	192,000	196,000	217,000	13	11
<b>Southside</b>	125,000	134,000	177,000	42	32
<b>Far Southwest</b>	98,000	117,000	160,000	63	37
<b>Statewide</b>	\$204,000	\$234,000	\$270,000	32%	15%

SOURCE: JLARC analysis of Monthly Median Sales Prices by County/Independent City, 2016 – present. Virginia REALTORS, updated July 15, 2021.

NOTE: Median cost home sales prices reflect the median prices in July of each year. Adjusted to 2021 dollars.

***Metropolitan Washington Council of Governments – The Future of Housing in Greater Washington***

Report can be found here: <https://www.mwco.org/documents/2019/09/10/the-future-of-housing-in-greater-washington/>

The Metropolitan Washington Council of Governments (MWCOG) is an independent, nonprofit association, with a membership of 300 elected officials from 24 local governments, the Maryland and Virginia state legislatures, and U.S. Congress.

**Key Findings:**

- Continued growth and an increased demand to live here, “...the region now finds itself in a challenging situation. There is an imbalance between the number of jobs and the amount of housing available to the workforce. This gap is expected to widen without intervention; the region is forecast to add approximately 413,000 new jobs to its employment base between 2020 and 2030, but only approximately 245,000 new housing units over the same period.”
- The Metropolitan Washington Council of Governments analysis “...showed the region needs, between 2020 and 2030, more than 75,000 additional households than what is currently anticipated (245,000 households). If the timeframe is stretched from 2020 to 2045, more than 100,000 additional households will be needed beyond the new households anticipated.”
- “At least 75% of new housing should be affordable to low-and middle-income households.”

## Virginia Housing Policy Advisory Council – Addressing the Impact of Housing for Virginia’s Economy (November 2017)

Report can be found here:

[https://www.vchr.vt.edu/virginiahousingeconomiclinkages#:~:text=In%20October%202014%2C%20Governor%20McAuliffe,Council%20\(HPAC\)%20was%20thus%20established](https://www.vchr.vt.edu/virginiahousingeconomiclinkages#:~:text=In%20October%202014%2C%20Governor%20McAuliffe,Council%20(HPAC)%20was%20thus%20established)

### *Background:*

In October 2014, Governor McAuliffe issued Executive Order (EO) 32, “Advancing Virginia’s Housing Policy,” to “identify and implement actions to enable quality, affordable housing, which will strengthen families and communities and foster economic growth.” The Housing Policy Advisory Council (HPAC) was thus established under the leadership of the Secretary of Commerce and Trade to help guide the development and implementation of Virginia’s housing policy.

A key directive of EO 32 was identifying the links between housing and economic and community development. To this end, the HPAC commissioned a study from a consortium of researchers at Virginia Tech, George Mason University, The College of William and Mary, and Virginia Commonwealth University, with the premise that successful housing policy must be based on independent analytic findings and best practices. The collaborative research of the four universities provides key information on the Commonwealth housing sector, focusing on the economic impact of housing, future scenarios impacting housing needs, and links between housing and other key policy sectors.

This report summarizes the research conducted by the four universities and the implications for Virginia’s housing policy development. The report is designed to assist stakeholders and policymakers think more creatively and collaborate more intensely at the state, regional, and local levels as Virginia strives to build on the successes of the past and meet the pressing housing challenges facing the commonwealth. The entirety of the research is included in nine papers presented here.

### *Key Findings:*

1. Virginia has a shortage of housing affordable to a substantial share of households. All regions of the state are experiencing significant shortages of affordable housing, as evidenced by the large share of households experiencing housing cost burdens across urban, suburban, and rural areas. Statewide, one in three households is cost burdened, spending more than 30 percent of their income for housing.
2. Failure to address affordable housing needs adequately has significantly affected key priorities of state policy, including economic and workforce development, transportation, education, and health.
3. Virginia needs to produce substantial new affordable housing to accommodate anticipated workforce growth. Virginia will need to house over 350,000 new workers in the next 10 years. The retirement of Baby Boomers and the entry of millennials into the workforce implies that a large share of new workers will be young with relatively low incomes and in need of affordable rental and homeownership units.
4. The homebuilding industry faces major challenges in meeting affordable housing needs. Nationally and in Virginia, the homebuilding industry faces challenges in affordable housing production for the following reasons:
  - a. Developable residential site shortages and high land costs near major employment centers
  - b. Construction labor supply constraints (especially in skilled trades)
  - c. Limited means for reducing rapid increases in development costs

5. Regions with lower combined housing and transportation costs have experienced better economic performance.

6. Virginia can no longer rely on the federal government to address critical housing needs. Federal housing appropriations are severely constrained, and fiscal stress is expected to further reduce federal housing expenditures and increase the likelihood of devolution of housing assistance responsibilities to the states.

[Appendix 2 of the report provides](#) estimates of the amount, type (single-family and multi-family), tenure (owner and renter), price or rent, and location of housing that the Commonwealth of Virginia will need to accommodate new workers over the next decade. During this time Virginia will add 357,800 net new jobs, but to ensure that this employment growth can occur, a sufficient supply of housing must be available for these new workers—in the right locations, of the right types, and at affordable prices and rents. The analysis produced estimates for the Commonwealth and 11 Virginia regions.

**Table 7. Net New Households by Home Price Affordable to Net New Households, Hampton Roads Region (2015 \$s)**

	2014-2024 Change		Share of Current Owner Households
	Households	Share of New Owner Households	
Less than \$100,000	2,550	12.3%	9.3%
\$100,000-199,999	7,250	35.2%	30.1%
\$200,000-299,999	6,650	32.1%	29.2%
\$300,000-399,999	2,850	13.8%	16.1%
\$400,000+	1,350	6.6%	15.3%
<b>Total</b>	<b>20,600</b>	<b>100.0%</b>	<b>100.0%</b>

Numbers may not sum due to rounding.  
Source: GMU Center for Regional Analysis

As shown in Table 8, the majority of new renters will earn over \$25,000, and will be likely to find apartments that will suit their needs based on the current distribution of rents. A gap is likely to increase for homes renting for less than \$625 per month, which would be affordable to households earning less than \$25,000. Over a quarter (26.7 percent or 5,600 households) of the new renter households formed by the new workers

**Table 3. Net New Households by Home Price Affordable to Net New Households, Charlottesville Region (2015 \$s)**

	2014-2024 Change		Share of Current Owner Households
	Households	Share of New Owner Households	
Less than \$100,000	900	15.5%	9.7%
\$100,000-199,999	1,800	31.7%	23.6%
\$200,000-299,999	1,800	31.9%	23.6%
\$300,000-399,999	850	15.0%	16.0%
\$400,000+	350	5.9%	27.1%
<b>Total</b>	<b>5,650</b>	<b>100.0%</b>	<b>100.0%</b>

Numbers may not sum due to rounding.  
Source: GMU Center for Regional Analysis

Similarly, some new renter households may have difficulty finding apartments at rents affordable to them. As shown in Table 4, about 1,200 new renter households will earn less than \$25,000, and need rental units below \$625 in order to spend less than 30 percent of their income on rent. An additional 1,500 renters will earn between \$25,000 and \$49,999, and can afford rents up to \$1,249.

**Table 11. Net New Households by Home Price Affordable to Net New Households, Lynchburg Region (2015 \$s)**

	2014-2024 Change		Share of Current Owner Households
	Households	Share of New Owner Households	
Less than \$100,000	950	41.5%	25.5%
\$100,000-199,999	650	28.0%	39.0%
\$200,000-299,999	500	22.3%	19.9%
\$300,000-399,999	150	6.4%	6.8%
\$400,000+	50	1.9%	8.8%
<b>Total</b>	<b>2,300</b>	<b>100.0%</b>	<b>100.0%</b>

Numbers may not sum due to rounding.  
Source: GMU Center for Regional Analysis

Likewise, the vast majority of new renter households will earn less than \$25,000 (Table 12). These 1,150 new renter households will be able to afford rents under \$625, and may have difficulty finding units. Currently, about 7,800 households rent for less than \$625, and the nearly 15 percent increase in demand for this product may be difficult to meet through new construction.

**Table 19. Net New Households by Home Price Affordable to Net New Households, Richmond Region (2015 \$s)**

	2014-2024 Change		Share of Current Owner Households
	Households	Share of New Owner Households	
Less than \$100,000	2,150	9.0%	10.6%
\$100,000-199,999	8,850	37.1%	35.7%
\$200,000-299,999	6,700	28.1%	27.3%
\$300,000-399,999	4,600	19.4%	13.4%
\$400,000+	1,550	6.4%	13.0%
<b>Total</b>	<b>23,800</b>	<b>100.0%</b>	<b>100.0%</b>

Numbers may not sum due to rounding.  
Source: GMU Center for Regional Analysis

As shown in Table 20, the new renter households will have more difficulty finding housing that is affordable to them. A quarter of new renters will be able to afford a maximum of \$625 in rent, but only 12.2 percent of current units rent in that range. Similar to other markets, new product in this price range may be difficult to build, forcing many of the new households to pay more than 30 percent of their income on rent.

### **National Low Income Housing Coalition – Out of Reach Report (2021)**

The National Low Income Housing Coalition’s Out of Reach report documents the significant gap between renters’ wages and the cost of rental housing across the United States. The report’s central statistic, the Housing Wage, is an estimate of the hourly wage a full-time worker must earn to afford a modest rental home at HUD’s fair market rent (FMR) without spending more than 30% of his or her income on housing costs, the accepted standard of affordability. The FMR is an estimate of what a family moving today can expect to pay for a modestly priced rental home in a given area.

*Virginia Report Card can be found here:*

<https://reports.nlihc.org/sites/default/files/oor/files/reports/state/va-2021-oor.pdf>

In Virginia, the Fair Market Rent (FMR) for a two-bedroom apartment is \$1,269. In order to afford this level of rent and utilities — without paying more than 30% of income on housing — a household must earn \$4,231 monthly or \$50,767 annually. Assuming a 40-hour work week, 52 weeks per year, this level of income translates into an hourly Housing Wage of \$24.41 per hour.

That translates into:

- 103 work hours per week at minimum wage to afford a two-bedroom rental home (at FMR)
- 88 work hours per week at minimum wage to afford a one-bedroom rental home (at FMR)
- 2.6 full time jobs at minimum wage to afford a two-bedroom rental home (at FMR)
- 2.2 full-time jobs at minimum wage to afford a one-bedroom rental home (at FMR)

## National Association of Home Builders – “Priced Out” Report (2022)

This article presents the NAHB’s “priced out estimates” for 2022, showing how higher prices and interest rates affect housing affordability. The 2022 US estimates indicate that a \$1,000 increase in the median new home price (\$412,5051) would price 117,932 households out of the market. As a benchmark, 87.5 million households (roughly 69 percent of all U.S. households) are not able to afford a new median priced new home. A \$1,000 home price increase would make 117,932 more households disqualify for the new home mortgage. Home prices surged during the pandemic, creating affordability challenges, particularly for first-time buyers.

Other NAHB estimates in this paper show that for 2022, 25 basis points added to the mortgage rate at 30-year fixed rate of 3.5% would price out around 1.1 million households. In addition to the national numbers, NAHB once again is providing priced out estimates for individual states and more than 300 metropolitan areas. Other Key Findings:

- 87 million households in the US (and 1.7 million households in Virginia) are not able to afford a new median priced new home in 2022
- 36 Million Households Can’t Afford a \$150,000 Home:
  - Using the same standard underwriting criterion as the priced-out estimates to determine affordability (that the sum of mortgage payments, property taxes, home owners and private mortgage insurance premiums should be no more than 28% of the household income), the minimum income required to purchase a \$150,000 home is \$36,074. In 2022, about 36 million U.S. households are estimated to have incomes at or below that threshold. Another 24.4 million can only afford a home priced between \$150,000 and \$250,000 (the second step on the pyramid). Each step represents a maximum affordable price range for fewer and fewer households.
- In Virginia, a \$1,000 increase in the median home price would price over 3,800 households out of the market

Report can be found here: [https://www.nahb.org/-/media/05E9E223D0514B56B56F798CAA9EBB34.ashx?\\_ga=2.213243421.805995588.1647882212-336051620.1620423394](https://www.nahb.org/-/media/05E9E223D0514B56B56F798CAA9EBB34.ashx?_ga=2.213243421.805995588.1647882212-336051620.1620423394)