

Application to DHCD Submitted through CAMS

Augusta County

Augusta County VATI 2019 Deerfield

Application ID: 59811262018124435
Application Status: In Progress - DHCD
Program Name: Virginia Telecommunications Initiative 2019
Organization Name: Augusta County
Organization Address: 18 Government Center Lane
Verona, VA 24482
Profile Manager Name: Jennifer Whetzel
Profile Manager Phone: (540) 245-5610
Profile Manager Email: jwhetzel@co.augusta.va.us

Project Name: Augusta County VATI 2019 Deerfield
Project Contact Name: Jennifer Whetzel
Project Contact Phone: (540) 245-5610
Project Contact Email: jwhetzel@co.augusta.va.us
Project Location: 18 Government Center Lane
Verona, VA 24482-0590
Project Service Area: Augusta County

Total Requested Amount: \$163,100.00
Required Annual Audit Status: Accepted

Application to DHCD Submitted through CAMS

Augusta County

Augusta County VATI 2019 Deerfield

Budget Information:

Cost/Activity Category	DHCD Request	Other Funding	Total
Telecommunications	\$163,100.00	\$69,900.00	\$233,000.00
Construction	\$163,100.00	\$69,900.00	\$233,000.00
Total:	\$163,100.00	\$69,900.00	\$233,000.00

Budget Narrative:

Construction budget consists of fiber placement, fiber-to-the-home, middle fiber run and site preparation costs. Local match is at 30% of the project and 70% of the project costs are requested from the VATI Grant.

Questions and Responses:

1. Project Area

Provide a map and description of the proposed geographic area including specific boundaries of the project area e.g.; street names, local and regional boundaries, etc. Explain why and how the project area(s) was selected. Attach a copy of your map(s).

Answer:

This proposed project is primarily a Fiber-to-the-Home (FTTH) style fiber build-out that would provide broadband access to the residents, businesses, and community anchor institutions in the Deerfield area. MGW has a point-of-presence (POP) in the Deerfield area which currently provides internet and phone services over a copper system and the highest speeds reported to the FCC are 10Mbps download and 1 Mbps upload. Therefore, this project and project area meets the definition of “unserved”. The proposed project includes approximately 11,500 ft of middle-mile fiber that would be placed along Deerfield Valley Road and Marble Valley Road, middle-mile fiber to nearby County-constructed cell tower, and approximately 15,500 ft of fiber feeders and service drops to provide a fiber connection to anyone in the project area that requests FTTH service.

Census Blocks are the geographic unit for which ISP’s report their deployment data to the FCC using the required Form 477. Aside from local knowledge of the existing telecommunications infrastructure in the County and results from our outreach efforts, the Form 477 data is a dataset commonly used to determine the location & internet speeds that internet service providers are providing in a specific Census Block. Therefore, this project area was defined using Census Block boundaries to ensure that the project area was eligible for VATI funding and did not overlap with any CAF funded areas. A Project Area Map is included with this application and depicts the project area along with the proposed infrastructure included in the scope of this project. The proposed project area meets the definition of unserved and is eligible for VATI funding. The 5 Census Blocks included in the project area are listed below:

Application to DHCD Submitted through CAMS

Augusta County

Augusta County VATI 2019 Deerfield

510150701003111

510150701003134

510150701003135

510150701003136

510150701003147

see attachment:4_ProjectAreaMap

2.

Describe your outreach efforts to identify existing providers in the selected project area. Provide a map and list of all existing providers (fixed and wireless), and speeds offered within the project area. Provide a detailed explanation of how this information was compiled and the source(s).

Answer:

Augusta County has been planning for and pursuing funding opportunities for broadband implementation projects for several years and completed a Broadband Telecommunications Strategic Plan in late-2016. Within the last year, the County formalized a Broadband Committee to spear-head broadband expansion projects and community education and outreach. In addition to the community surveys performed during the development of the broadband plan, a significant outreach effort was made specific to this application to the 2019 VATI program. The information collected during the outreach efforts confirmed that the citizens and business in this area have struggled with inadequate connectivity for far too long and this is one of the more unserved areas of the County. Unlike fixed wireless, a fiber internet project provides broadband availability to every location it passes- not just those that might have line-of-sight to a tower or antenna many miles away. In addition, the bandwidth required by the locations (and not just the businesses, home-based business, and ag-based businesses) in this area are well beyond what DSL or fixed wireless may provide. With the fiber internet service, anyone in the proposed project area would be able to get internet speed packages up to 1 Gbps. Here is a timeline for the most recent outreach efforts, including the required public comment period:

- Oct. 10, 2018 - County released RFP/RFI to identify an internet service provider (ISP) to partner with on a VATI application (emailed directly to 7 ISP's known to provide some internet service in the County)
- Oct. 30, 2018 - deadline for responses to the RFP/RFI (identified partnering ISP)
- Nov. 16, 2018 - released a notice for public comment (newspaper, website)
- Nov. 27, 2018 - mailed out 95 "internet survey" letters in the project area
- Nov. 28, 2018 - Board meeting where comments on VATI application were heard

Application to DHCD Submitted through CAMS

Augusta County

Augusta County VATI 2019 Deerfield

The County received 20 responses from the mail-out in the project area, and the results/comments speak for themselves. The responses generally fell into the following categories: (1) no internet available, (2) poor DSL service (very old copper plant in this area), or (3) slow, unreliable satellite service. Our partnering ISP, Lingo Networks, has a few customers in this area that are serviced with a DSL connection, and the proposed project would replace the limited DSL service with unlimited FTTH service. The County, as well as, the ISP have received phone calls from residents in the area reiterating the need for this project, some of which also commented about the poor cell service in the Deerfield area. All the documentation for these numerous outreach efforts is included in an attachment.

These outreach efforts helped identify existing ISP's in the project area. A map titled, "Deerfield Outreach Effort", is included in the attachment and presents 2 of the responses from a past survey- who their ISP is and if they are satisfied with their service. We also reviewed the most recent Form 477 data from the FCC as a dataset commonly used to identify unserved areas. After a detailed review of these outreach efforts and an analysis of the "boots of the ground" information, it was determined that there are no locations receiving internet speeds of 10/1 or greater- the project area is eligible for VATI funding. We understand that the 2019 VATI program allows for a 10% overlap and includes a challenge process. Despite the Form 477 showing some areas having 12/3, that information is incorrect, and the due diligence has been done to define this area as unserved. Our local ISP's which participate in the County's broadband planning and implementation efforts, as well as, everyone living or working in the project area agree with this assessment and eagerly await reliable, high-speed internet.

see attachment:Opt1_OutreachDocs

3. Project Need/Description

To be eligible for VATI, applicants must demonstrate that the proposed project area(s) is unserved. An unserved area is defined as an area with speeds of 10 Mbps/1 Mbps or less, and with less than 10% service overlap within the project area. Describe the anticipated service overlap with current providers within the project area.

Answer:

According to our survey data and various outreach efforts, the proposed project area is unserved and eligible for VATI. During our analysis of the FCC's Form 477 data, we were shocked to see that an ISP (Rural Broadband Network Service, LLC d.b.a. High Speed Link) recently reported having speeds of 12/3 available in almost the entire County. In Attachment #11 - Unserved, we've included (1) a table with the Form 477 for the 5 census blocks in the proposed project area, (2) a map of the County showing the census blocks reported by this provider as having 12/3 available, and (3) a map showing our survey and outreach data. This is the only provider in the 5 census block project area reporting any speeds over 10/1. If this was true, then broadband (>10/1 per VATI guidelines) would be available in 95% of the County- which it is not. At no time during any of our outreach efforts has someone in the area stated that they have service from that ISP. Also, in speaking with others in the industry about this potentially over-reported data, and knowing the locations & equipment utilized by this provider, we feel that in this case the Form 477 data should not be used to define whether the proposed project area is unserved. If this provider decides to utilize the challenge process set forth in the VATI guidelines, it would then be up to them to prove that they truly have the coverage represented by the Form 477 they have submitted to the FCC.

Application to DHCD Submitted through CAMS

Augusta County

Augusta County VATI 2019 Deerfield

In addition, fiber ensures that the state, local, and private funding is invested into a technology that can meet the bandwidth needs of the future. Based upon our local knowledge of the area, our survey results, and numerous outreach efforts- the Deerfield Fiber Project meets the definition of unserved and is eligible for VATI.

see attachment:#11-Unserved

4. Describe population both in terms of absolute numbers within the project area and the eligible users that will be served by the proposed project. Describe the basis for these projections.

Answer:

Demographic data provided by the Census Bureau is only available at the Census Block level during their decennial release. The 2010 population for the 5 Census Blocks included in the proposed project area is 118, and the number of housing units is 67. There are approximately 112 structures with 911 addresses in the project area.

It is anticipated that the middle-mile fiber would pass approximately 63 eligible users, and assuming a take rate of around 50%, there are 30 FTTH installation includes in the scope & budget of the proposed project.

5. Indicate the numbers of businesses and community anchor institutions the proposed project will pass in the project area.

Answer:

A windshield survey was performed to get a best-guess count on the total number of businesses and community anchor institutions located within the project area. The County also pulled business licenses and other information to assist in the identification of economic development assets to be included in the 2019 VATI application. Including ag-related and home-based businesses, there are at least 2 businesses within the project area. In addition, there are community anchor institutions in the project area. They include the Deerfield Volunteer Fire Department, Deerfield Library Station, a National Park Service facility, a US Post Office, Deerfield Grocery, a telecommunications tower, several churches, Cool Springs Farm, and other agricultural operations. Some structures/locations that were removed from the analysis of eligible users and included barns, cabins/camps, and properties with more than one 911 address.

see attachment: Opt2- CAI_Business

6. Provide the anticipated take rate for the proposed service within one year of project completion and describe the basis for the estimate. Also provide all actions to be implemented to reach the identified potential customers within the project area.

Answer:

Using past projects as a guide, it is anticipated that approximately 30 of the possible 63 eligible users will request a FTTH connection during the initial construction and those service drops are included as a line item in the project budget. This would place the proposed take rate during the first year that the fiber is available around 50%.

As MGW/Lingo has done with past projects completed under a Public Private Partnership, an initial marketing/informative letter will be mailed to all prospective addresses in the project area. Depending on the return correspondence, door-hangers may also be used to inform the landowner or tenant of the opportunity to receive a

Application to DHCD Submitted through CAMS

Augusta County

Augusta County VATI 2019 Deerfield

FTTH connection. Once construction begins, it is common (especially in rural areas) for people in the area to stop and talk with the fiber crew to get in-person information about the project. In addition, there have been cases within past projects where the landowner or tenants desired to wait out an existing contract before entering into a new contract for service. MGW/Lingo has been flexible with potential clients in that regard while also meeting the deadlines of the VATI program.

7. A statement whether the proposed project is targeting the “last mile,” “middle mile,” or “backbone” portion of the broadband infrastructure.

Answer:

The proposed project was designed to facilitate last-mile, FTTH connections. In terms of linear feet, the proposed project is 42.5% middle-mile and 57.5% last-mile. This does not include the option for a fiber installation to the cell tower that holds public safety equipment.

8. For wireless projects only: Please explain the ownership of the proposed wireless infrastructure. Will the wireless co-applicant own or lease the radio mast, tower, or other raised structure onto which the wireless infrastructure will be installed?

Answer:

The proposed project does not include a “wireless” component.

9. Provide a description of the broadband service to be provided, including estimated download and upload speeds, whether that speed is based on dedicated or shared bandwidth, and the technology that will be used. This description can be illustrated by a map or schematic diagram, as appropriate.

Answer:

The broadband service in the proposed project is considered Fiber-to-the-Premise (FTTP) or Fiber-to-the-Home (FTTH). The proposed project is an extension off MGW/Lingo’s fiber network which is a carrier-class network that provides bandwidth to schools, hospitals, large and small resort facilities, and thousands of residential customers. There is an existing point-of-presence (POP) that will house the broadband distribution switch and other network electronics. The network is designed to be scalable to ensure it can serve future development and bandwidth needs. The actual download/upload speeds would be the speeds selected by the customer, and below is a list of the standard speed packages currently being offered by MGW/Lingo Networks:

SILVER25Mb Download x 5 Mbps Upload
GOLD50Mb Download x 10 Mbps Upload
PLATINUM100Mb Download x 20 Mbps Upload
PLATINUM ELITE200Mb Download x 40 Mbps Upload
*Custom packages are available with speeds up to 1 Gbps

see attachment:#Opt3 - Network Diagrams

10. Provide a description of the network system design used to deliver broadband service from the network’s primary Internet point(s) of presence to end users, including the network components that already exist and the ones that would be added by the proposed project. Also describe specific advantages of using this technology. Provide a detailed explanation on how this information was compiled and source(s). For wireless projects, provide a propagation map including the proposed project.

Application to DHCD Submitted through CAMS

Augusta County

Augusta County VATI 2019 Deerfield

Answer:

Lingo Networks shall deploy a FTTP network architecture which allows for the delivery of voice and data services across the broadband access platform. MGW/Lingo will utilize redundant Ethernet uplinks from the proposed FTTP electronics to its existing softswitch to facilitate voice services. The fiber optic cable infrastructure will be designed in a manner that permits MGW/Lingo to utilize various technologies such as Active Ethernet, Gigabit Passive Optical Network (GPON), or various other next-generation technologies. Redundant connections ensure highly reliable broadband data communications services and MGW/Lingo will utilize its existing and new data network routers, Internet uplinks, and ISP services as needed. MGW/Lingo has a point-of-presence (POP) less than 500 ft away from proposed project area which will house the FTTP electronics and be the hub for the fiber network designed to serve the proposed project area.

New network components that would be added as part of the proposed project include a broadband distribution switch, passive optical splitters, fiber pedestals and enclosures, splicing trays, an ONT or other DMARC at the customers location, and a router or other customer-premise-equipment (CPE) as needed or requested.

see attachment: #Opt3- Network Diagrams

11. Project Readiness

What is the current state of project development (i.e. planning, preliminary engineering, final design, etc.)? Prepare a detailed project timeline or construction schedule, which identifies specific tasks, staff, contractor responsible(s), collection of data, etc., and estimated start and completion dates. The timeline should include all activities being completed within 12 months of contract execution with DHCD.

Answer:

The current state of project development could be considered beyond the planning phase and well into the engineering phase. MGW is a telecom utility and performs the majority of their engineering, permitting, and landowner negotiations in-house, as well as, main cable and drop cable construction. Upon the Governor's announcement of an award, we would immediately send out letters to the addresses in the project area informing them of the project and to sign-up for a free FTTH installation. At the same time, Land Use Permit (LUP) applications will be submitted to VDOT for the middle-mile portion of the project. MGW/Lingo has been selected through competitive procurement processes for broadband projects in the past, including projects that were administered through a Public Private Partnership. Minimal work would be required prior to the start of construction, therefore this project is considered to be shovel-ready.

12. Matching funds: Provide a description of the matching funds the applicant and co-applicant will invest in the proposed project, (VATI funding cannot exceed 80% of total project cost). The Funding Sources Table should be completed.

i. For each element of matching funds in the description, indicate the type of match (cash, salary expense, or in-kind contribution).

ii. Identify whether the applicant or co-applicant is responsible for providing each element of the proposed matching funds.

iii. Include copies of vendor quotes or documented cost estimates supporting the proposed budget.

Application to DHCD Submitted through CAMS

Augusta County

Augusta County VATI 2019 Deerfield

Answer:

The County and its partnering ISP are proposing to provide a combined match of 30%, greater than the 20% required by the VATI program. The entirety of this 30% match shall be in cash and documentation of this financial commitment from both the County and the ISP are included with this application.

see attachment:

#10 Match Commitment

see attachment:

#13 Funding Sources Table

13. Identify key individuals, including name and title, who will be responsible for the management of the project. Describe their role and responsibilities for the project. Present this information in table format.

Answer:

A table has been prepared with information on key personnel assigned to the project and has been uploaded as an attachment.

see attachment:#Opt4 - Key Personnel

14. Applicant and Co-Applicant: A description of the public-private partnership involved in the project. Detail the local government assistance: Local government co-applicants should demonstrate assistance to project that will lower overall cost and further assist in the timely completion of construction, including assistance with permits, rights of way, easement and other issues that may hinder or delay timely construction and increase cost.

i. If the partnership is formalized in a written agreement provide a copy of that agreement.

ii. If the partnership has not been formalized, provide a short description of the project management role, financial commitment, or other contribution to the project for the applicant and co-applicant and any additional partners.

Answer:

Augusta County and MGW/Lingo have entered into Public-Private Partnership agreements in the past and have been successful implemented projects, including projects that included State funding. MGW/Lingo is a telecommunications utility and will be handling all the middle-mile and last-mile construction with its own buried fiber and fiber splicing crews. In addition, MGW/Lingo has included the costs for their engineering and permitting at no cost (value-added item) in the scope of the project. Therefore, this project is a 100% construction project. The local government co-applicant will assist with informing the residents in the project area and achieving the greatest take-rate possible.

A draft of the Public-Private Partnership agreement is attached to the application for review.

see attachment #6:Draft PPP Agreement

15. Project Budget and Cost Appropriateness

Applicants shall provide a detailed budget as to how the grant funds will be utilized, including an itemization of equipment and construction costs and a justification of proposed expenses. Expenses should be substantiated by clear cost estimates.

Application to DHCD Submitted through CAMS

Augusta County

Augusta County VATI 2019 Deerfield

Answer:

The budget for the proposed project is encompassed into a single line item in CAMS for construction. The partnering ISP will be performing all the construction, so no other contractors will be necessary for the project. This includes both the middle-mile and the last-mile components of the proposed project. Since the price of fiber cable fluctuates frequently, the partnering ISP has several vendors it uses for purchasing large amounts of cable (i.e. 10,000-20,000' reels) and will purchase the cable needed for this project immediately upon the signing of the pre-contract agreements and VATI contract. Similar to how the cost for fiber plow machine, directional bore machines, rock saws, fiber splicing equipment, etc. is included in the ISP's per foot or per mile cost estimates- the cost of the buried mainline fiber and buried service drops are also built in. The budget, like the scope, have been kept very simple in order to maximize the amount of fiber (broadband) deployment during the 1-year contract period. Below are the handful of line items that will be used to track the progress of the project:

- | | |
|---|-------------------|
| • Middle-mile Fiber Construction (2.2 miles installed) | \$115,000 |
| • Middle-mile Fiber Construction (3,000' tough terrain) | \$35,000 |
| • Broadband Distribution Switch (Calix OLT) | \$12,500 |
| • Pedestals/Handholes (25) | \$12,500 |
| • Enclosures/Splitters/Splice Trays | \$6,500 |
| • Last-mile Fiber (30 FTTH connections) | \$45,000 |
| • Customer ONT/CPE (30 customers) | \$6,500 |
| • Network Engineering & Permitting | \$0.00 (in-house) |

Total Project Cost \$233,000

Here the line items above have been categorized into middle-mile and last-mile components:

- | | |
|---|-----------|
| • Middle-mile fiber construction | \$181,500 |
| • Last-mile service drops (\$1,500 x 30 FTTH) | \$51,500 |

Total Project Cost \$233,000

16. The cost benefit index is comprised of three factors: (i) state share for the total project cost, (ii) state cost per unit

Application to DHCD Submitted through CAMS

Augusta County

Augusta County VATI 2019 Deerfield

passed, and (iii) the internet speed. From these statistics, individual cost benefit scores are calculated. Finally, the three component scores are averaged together and converted to a 30 point scale to form a composite score.

Answer:

Cost Benefit Index

(i) State share of both middle-mile and last-mile=\$163,100 (w/ fiber to the tower)=\$138,600 (w/o fiber to the tower)

(ii)State cost per unit passed:

- 63 addresses passed by proposed middle-mile cable
- 30 FTTH installations included in scope due to 1-yr contract
- project includes over 2.7 miles of middle-mile fiber & approximately 2.8 miles of last-mile fiber

(iii)Internet Speed available in the project area is up to 1 Gbps

$\$138,600 / 63 \text{ addresses passed} = \$2,200.00$

17. A description of applicant and co-applicant's history or experience with managing grants and constructing broadband communications facilities in the Commonwealth of Virginia and elsewhere.

Answer:

MGW Telephone was incorporated in 1967 with the mission of bringing telecommunications services to the rural communities of the Shenandoah Valley region. MGW Networks was formed in 1999 and Lingo Networks in 2011, and currently provide telecommunications services in 11 counties in Virginia. MGW & Lingo Networks transports local, LD and internet traffic for Verizon landline, Verizon wireless, Highland Telephone Cooperative, TDS Telephone, Lumos, AT&T, and New Hope Cooperative. MGW maintains over 250 miles of active fiber in the western part of Virginia. We have fiber installation buried crew, in house engineering, splicing crew, network managed services, NOC, and carrier equipment manufacturing.

MGW employs a Strategic Planning Director with over a decade of experience managing grants, including broadband planning and broadband implementation grants. MGW/Lingo was a co-applicant on a successful 2017 VATI application whereby several miles of middle-mile fiber was installed, approximately 40 FTTH connections were made, and a new 195' tower was constructed to facilitate fixed wireless services in the areas where fiber build-out may be 10+ years out.

The County has received and successfully managed many grants over the years, including Homeland Security, Watershed Rehabilitation Program, Edward Byrne Memorial Justice Assistance Grant Program, Highway Planning and Construction, and Staffing for Adequate Fire and Emergency Response (SAFER).

Jennifer Whetzel is the Deputy County Administrator for Augusta County. In this role, she oversees the Finance, IT, Parks & Recreation, Library and ECC departments. Prior to her current position, Ms. Whetzel worked for a regional public accounting firm and as the Finance Director for the County. In this role, she managed several key functions, including grant reporting. She prepared the application for the 2016 Virginia Telecommunications Planning Initiative Grant (VATPI) and 2017 Virginia Telecommunications Initiative (VATI), both of which were awarded to the County by the Virginia Department of Housing and Community Development.

Application to DHCD Submitted through CAMS

Augusta County

Augusta County VATI 2019 Deerfield

see attachment:#10 - Match Source

18. Service

Describe the Internet service offerings to be provided after completion of this project and your price structure for these services. The service offerings should include all relevant tiers.

Answer:

Below are MGW/Lingo's standard fiber internet packages currently listed on their fiber internet service application. Custom packages with speeds up to 1 Gbps are available upon request.

SILVER25Mb Download x 5 Mbps Upload
GOLD50Mb Download x 10 Mbps Upload
PLATINUM100Mb Download x 20 Mbps Upload
PLATINUM ELITE200Mb Download x 40 Mbps Upload

19. Additional Information

Any other equitable factor that the applicant desires to include.

Answer:

N/A

Attachments:

Derivation of Cost (Project Budget)

1DerivationofCostsWorksheet12132018100911.pdf

Project Management Plan

2ProjectManagementPlan1213201873412.pdf

Supporting documentation for costs estimates

3CostEstimates1213201873416.pdf

Map(s) of project area, including proposed infrastructure

4ProjectAeaMap1213201873420.pdf

Application to DHCD Submitted through CAMS

Augusta County

Augusta County VATI 2019 Deerfield

Map(s) or schematic of existing broadband providers (inventory of existing assets)

5ExistingProviders1213201873615.pdf

Documentation of relationship between applicant and co-applicant (formal or informal)

6DraftPPPAgreement1213201873624.pdf

Two most recent Form 477 submitted to FCC

7Form477filings1213201873628.pdf

Documentation for in-kind contributions, including value(s)

8InKind1213201873632.pdf

Documentation supporting project costs (i.e. vendor quotes)

9ProjectCosts1213201873637.pdf

Documentation of source of match funding

10MatchSource1213201873641.pdf

Documentation that proposed project area is unserved based on VATI criteria

11Unserved1213201873647.pdf

Documentation that proposed project area is not designated for Connect America Funding (CAF)

12CAFDeerfield1213201873652.pdf

Funding Sources Table

13FundingSourcesTable1213201873656.pdf

(Optional)

Opt1OutreachDocs1213201873702.pdf

(Optional)

Opt2CAIBusiness1213201873707.pdf

Application to DHCD Submitted through CAMS

Augusta County

Augusta County VATI 2019 Deerfield

(Optional)

Opt3NetworkDiagrams1213201873711.pdf

(Optional)

Opt4KeyPersonnel1213201873717.pdf

Derivation of Cost Worksheet

VATI 2019 Application - Augusta County - Deerfield Fiber Project - Attachment #1

Product	Total	VATI	Non-VATI	Source of Estimate	Date
<u>Construction</u>					
2.7 miles of middle-mile fiber (includes network appurtances)	\$ 146,500.00	\$ 102,550.00	\$ 43,950.00	Lingo Networks	10/30/2018
3,000' of middle-mile fiber (rough terrain)	\$ 35,000.00	\$ 24,500.00	\$ 10,500.00	Lingo Networks	10/30/2018
2.8 miles of last-mile fiber and FTTH (includes CPE- customer premise equipment)	\$ 51,500.00	\$ 36,050.00	\$ 15,450.00	Lingo Networks	10/30/2018
Engineering & Permitting (performed in-house at Lingo Networks; valued at 10% project cost)	\$ -	\$ -	\$ -	Lingo Networks	10/30/2018
TOTAL	\$ 233,000.00	\$ 163,100.00	\$ 69,900.00		



December 3, 2018

Ms. Jennifer M. Whetzel
Deputy County Administrator
County of Augusta
Verona, Virginia 24482

RE: Cost Estimates for Deerfield Fiber Project

Dear Ms. Whetzel,

The cost estimates provided by MGW/Lingo Networks (“Lingo”) for the Deerfield Fiber Project were derived from (1) the standard materials costs quoted by our vendors, (2) Lingo’s standard installation costs for buried fiber optic cable, and (3) costs from recent projects of similar size and outcomes.

Having deployed fiber in a variety of locations in the Shenandoah Valley area, our cost estimates for main cable construction vary based upon terrain and available public right-of-way. For service drops, our policy is to provide a free installation up to 1,000’ in length and for that portion of the project. Due to varying distances and terrain, our estimates includes an average cost of \$1,500 per FTTH installation.

Below is a table which lists the project materials, installations, and vendor/installer for each:

MATERIAL/INSTALLATION	VENDOR/INSTALLER
Fiber Optic Cable, Pedestals, & Network Cabinets	Power & Tel
Middle-mile fiber construction	MGW/Lingo Networks
Fiber-to-the-Home installations	MGW/Lingo Networks

Feel free to contact me with any questions you may have at (540) 448-1336 or by sending an email to craig.smith@mgwnetworks.com

Sincerely,
Lingo Networks

R. Craig Smith, President

Deerfield Fiber Project

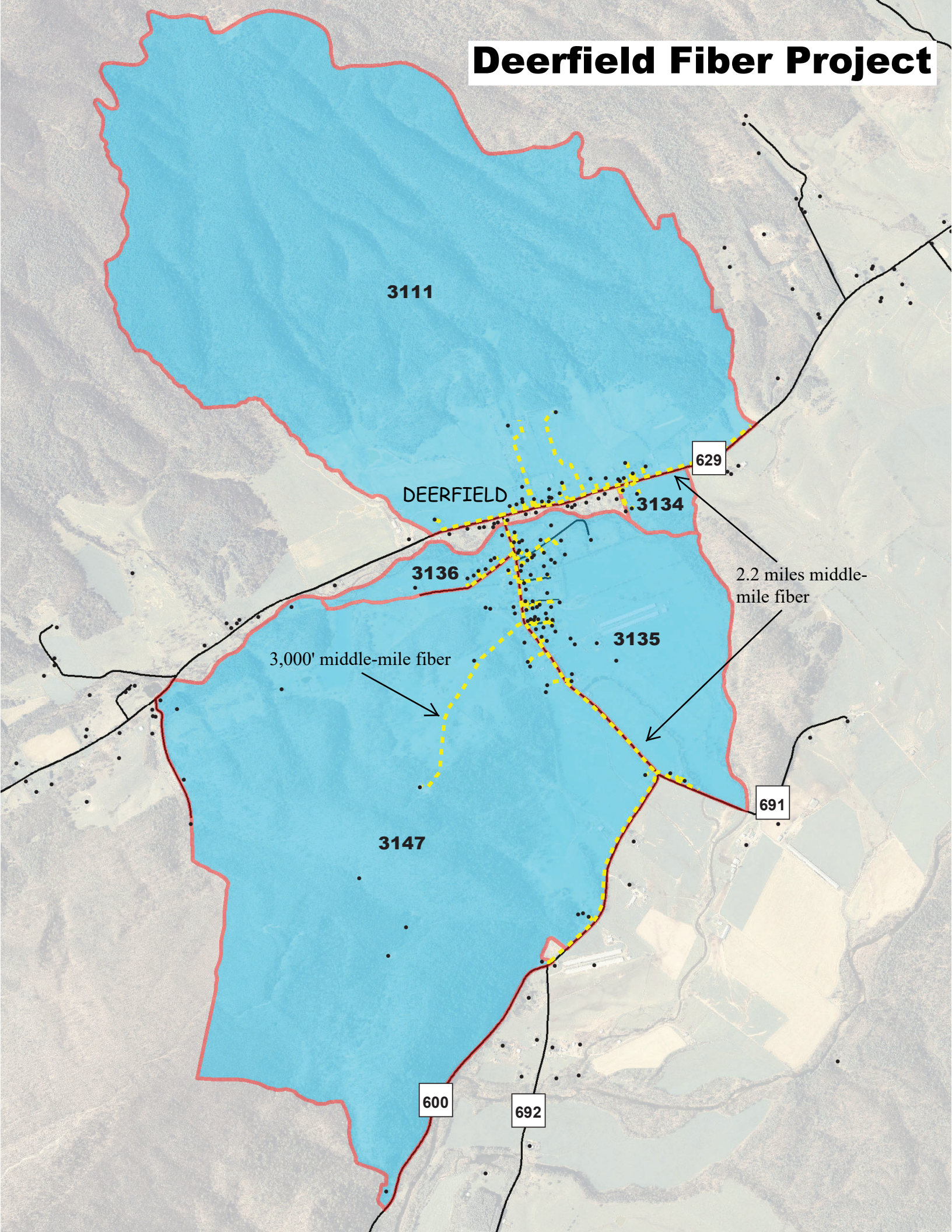

3111

DEERFIELD

3136

3,000' middle-mile fiber

3147

600

692

3134

3135

629

2.2 miles middle-mile fiber

691

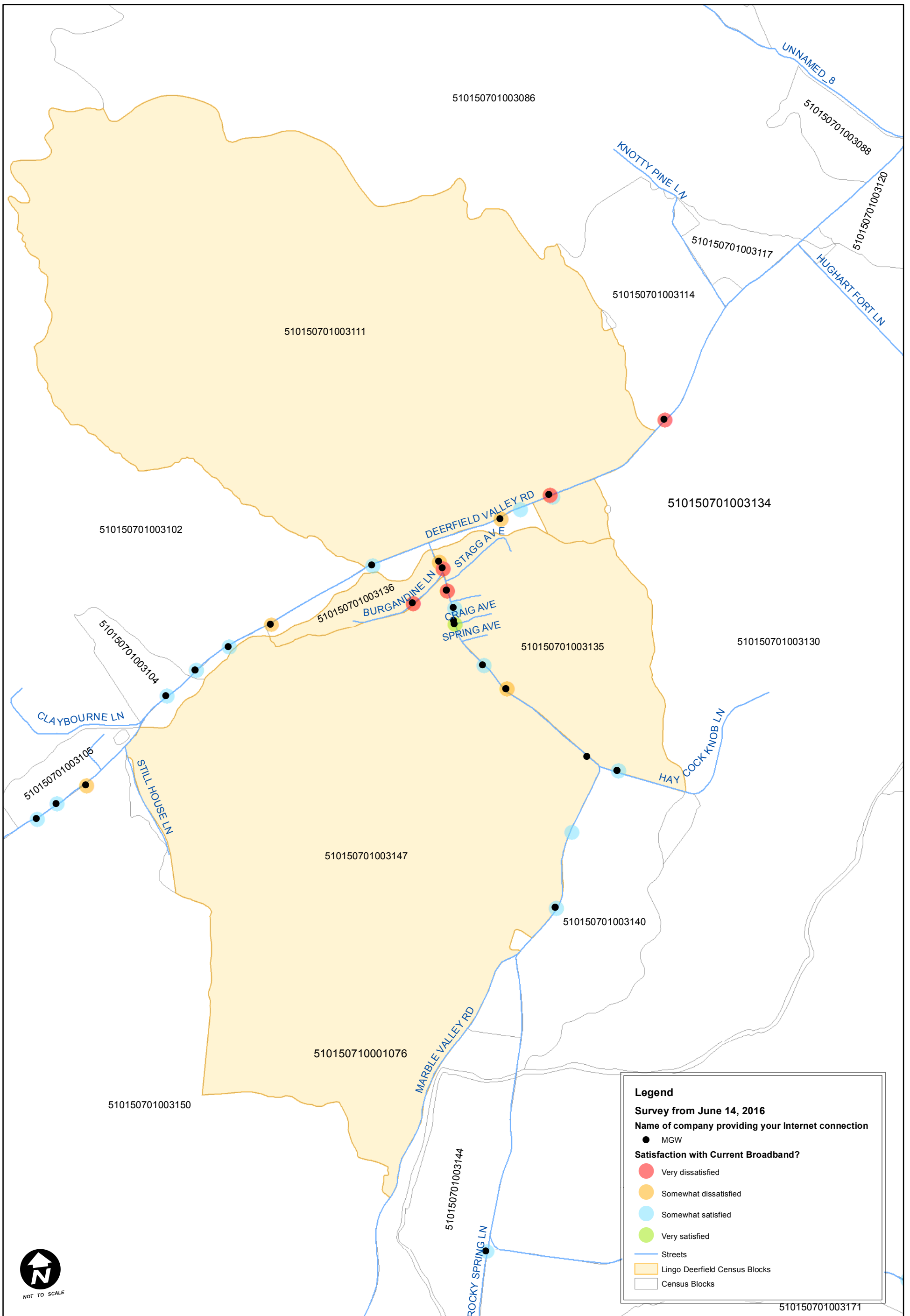

Deerfield Outreach Effort



FCC Form 477 Data for Deerfield Project Area

ProviderName	DBAName	CensusBlock	TechCode	MaxAdDown	MaxAdUp
MGW Telephone Company, Inc.	MGW Telephone	510150701003111	10	10	1
Rural Broadband Network Services LLC	HighSpeedLink.net	510150701003111	70	12	3
Rural Broadband Network Services LLC	HighSpeedLink.net	510150701003134	70	12	3
MGW Telephone Company, Inc.	MGW Telephone	510150701003135	10	10	1
Rural Broadband Network Services LLC	HighSpeedLink.net	510150701003135	70	12	3
MGW Telephone Company, Inc.	MGW Telephone	510150701003136	10	10	1
Rural Broadband Network Services LLC	HighSpeedLink.net	510150701003136	70	12	3
MGW Telephone Company, Inc.	MGW Telephone	510150701003147	10	10	1
Rural Broadband Network Services LLC	HighSpeedLink.net	510150701003147	70	12	3

Agreement

This agreement is made on _____, _____ between **MGW/Lingo Networks**, 27 North Central Avenue, Staunton, Virginia 24401 (“Company”), and the **County of Augusta**, Virginia, Attn: County Administrator’s Office, 18 Government Center Lane, P.O. Box 590, Verona, Virginia 24482 (“County”).

RECITALS:

- A. Whereas, the Department of Housing and Community Development (DHCD) will be implementing the Virginia Telecommunications Initiative (VATI) grant program; and
- B. Whereas, the primary objective of the VATI is to provide financial assistance to supplement construction costs by private sector broadband service providers, in partnership with local units of government to extend service to areas that presently are unserved or underserved by any broadband provider; and
- C. Whereas, applications must be submitted by a unit of government (Towns, Cities, Counties, EDA/IDA, Broadband/Wireless Authorities, Planning District Commissions, etc.) with a private sector provider(s) as a co-applicant; and
- D. Whereas, the County has completed a Broadband Telecommunications Strategic Plan and issued a Request for Information seeking Internet Service Providers to partner with the County to submit an application for the VATI grant program; and
- E. Whereas, MGW/Lingo Networks submitted a proposal for broadband deployment solutions in the County; and
- F. Whereas, the County and MGW/Lingo Networks will partner for a grant application for the VATI grant program.

NOW, therefore, the parties agree that they will uphold the following responsibilities:

THE COUNTY:

1. The County will manage the VATI grant requirements with DHCD, including, but not limited to progress reports and monthly funding draws; and
2. The County will provide assistance with GIS mapping and zoning requirements throughout the project, which will be included as in-kind match for the VATI grant; and
3. The County will assist with educating the public about the project and services to be available in their areas.

THE COMPANY:

4. The Company will provide the County required information for the management of the VATI grant, including, but not limited to progress reports and monthly invoices; and
5. The Company will provide the required documents to the County for zoning and permit applications; and
6. The Company will design, engineer, construct and implement broadband services as designated in the VATI application by the May 30, 2020 grant deadline, and
7. The Company will guarantee that the minimum bandwidth offerings for the projects will be 25 Mbps download and 3 Mbps upload; and

8. The Company will guarantee that Verizon cellular service is available to the project area designated in the VATI application; and
9. The Company will lease or own the assets associated with the projects.

This agreement will terminate when DHCD notifies the County that all grant requirements have been satisfied.

Witness the following authorized signatures on behalf of the parties:

Date

By: _____
R. Craig Smith
President, MGW/Lingo Networks

Date

By: _____
Timothy K. Fitzgerald
County Administrator



(RETAIN FOR YOUR RECORDS)
Form 477 Filing Summary

FRN: 0019225366 | Data as of: Jun 30, 2018 | Operations: Non-ILEC | Submission Status: Original - Submitted | Last Updated: Sep 3, 2018 10:37:51

Filer Identification

Section	Question	Response
Filer Information	Provider Name	MGW Networks, L.L.C.
	Holding Company Name	MGW Communications, Inc.
	SAC ID	
	499 ID	828775
Data Contact Information	Data Contact Name	Sheri H Smith
	Data Contact Phone Number	(540) 925-5235
	Data Contact E-mail	sheri.smith@mgwnetworks.com
Emergency Operations Contact Information	Emergency Operations Name	R. Craig Smith
	Emergency Operations Phone Number	(540) 925-2258
	Emergency Operations E-mail	craig.smith@mgwnetworks.com
Certifying Official Contact Information	Certifying Official Name	Sheri H. Smith
	Certifying Official Phone Number	(540) 925-5235
	Certifying Official E-mail	sheri.smith@mgwnetworks.com

Data Submitted

Form Section	File Name	Date & Time	Number of Rows
Fixed Broadband Deployment	477_MGWNetworksLingoDeployment_20180630.csv	Aug 30, 2018 12:43:48	6884
Fixed Broadband Subscription	477_NETWORKSLINGOBroadband Subscription_6_30_2018F.csv	Aug 28, 2018 22:55:44	238
Fixed Voice Subscription	477 NetworksLingoVoiceTelephoneSubscription_6_30_2018.csv	Aug 28, 2018 21:49:21	16



(RETAIN FOR YOUR RECORDS)
Form 477 Filing Summary

FRN: 0019225366

Data as of: Dec 31, 2017

Operations: Non-ILEC

Submission Status: Revised - Submitted

Last Updated: Aug 27, 2018 16:28:28

Filer Identification

Section	Question	Response
Filer Information	Provider Name	MGW Networks, L.L.C.
	Holding Company Name	MGW Communications, Inc.
	SAC ID	
	499 ID	828775
Data Contact Information	Data Contact Name	Sheri H Smith
	Data Contact Phone Number	(540) 925-5235
	Data Contact E-mail	sherihsmith@mgwnet.com
Emergency Operations Contact Information	Emergency Operations Name	R. Craig Smith
	Emergency Operations Phone Number	(540) 925-2258
	Emergency Operations E-mail	rcraigsmith@mgwnet.com
Certifying Official Contact Information	Certifying Official Name	Sheri H Smith
	Certifying Official Phone Number	(540) 925-5235
	Certifying Official E-mail	sherihsmith@mgwnet.com

Data Submitted

Form Section	File Name	Date & Time	Number of Rows
Fixed Broadband Deployment	477MGWNETWORKSLINGOBROADBANDDEPLOYMENT_12312017F.csv	Jun 12, 2018 16:17:29	6877
Fixed Broadband Subscription	Revised477MGWNETWORKSLINGOBROADBANDSUBS_12312017F.csv	Jun 12, 2018 16:20:53	228
Fixed Voice Subscription	477 MGWNETWORKS VOICE SUBSCRIPTION_MKT 2 and 3_12_31_17.csv	Jun 12, 2018 16:17:29	14

There are no in-kind contributions included in the budget for the proposed project. The local and private match contributions exceed what is required by the VATI program and will be 100% cash match.



December 3, 2018

Ms. Jennifer M. Whetzel
Deputy County Administrator
County of Augusta
Verona, Virginia 24482

RE: Cost Estimates for Deerfield Fiber Project

Dear Ms. Whetzel,

The cost estimates provided by MGW/Lingo Networks (“Lingo”) for the Deerfield Fiber Project were derived from (1) the standard materials costs quoted by our vendors, (2) Lingo’s standard installation costs for buried fiber optic cable, and (3) costs from recent projects of similar size and outcomes.

Having deployed fiber in a variety of locations in the Shenandoah Valley area, our cost estimates for main cable construction vary based upon terrain and available public right-of-way. For service drops, our policy is to provide a free installation up to 1,000’ in length and for that portion of the project. Due to varying distances and terrain, our estimates includes an average cost of \$1,500 per FTTH installation.

Below is a table which lists the project materials, installations, and vendor/installer for each:

MATERIAL/INSTALLATION	VENDOR/INSTALLER
Fiber Optic Cable, Pedestals, & Network Cabinets	Power & Tel
Middle-mile fiber construction	MGW/Lingo Networks
Fiber-to-the-Home installations	MGW/Lingo Networks

Feel free to contact me with any questions you may have at (540) 448-1336 or by sending an email to craig.smith@mgwnetworks.com

Sincerely,
Lingo Networks

R. Craig Smith, President

COUNTY OF AUGUSTA, VA.

BOARD OF SUPERVISORS

MARSHALL W. PATTIE
North River

GERALD W. GARBER
Middle River

TRACY C. PYLES, JR.
Pastures

TERRY L. KELLEY, JR.
Beverley Manor

WENDELL L. COLEMAN
Wayne

MICHAEL L. SHULL
Riverheads

CAROLYN S. BRAGG
South River

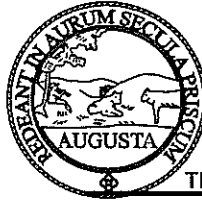

TIMOTHY K. FITZGERALD – COUNTY ADMINISTRATOR

AUGUSTA COUNTY GOVERNMENT CENTER

P.O. BOX 590, VERONA, VA 24482-0590

(540) 245-5610 FAX (540) 245-5621

coadmin@co.augusta.va.us

18-119

M E M O R A N D U M

TO: Jennifer Whetzel, Deputy County Administrator

FROM: Timothy K. Fitzgerald, County Administrator *TKF*

DATE: November 15, 2018

SUBJECT: Broadband Grant

The Augusta County Board of Supervisors, at its Wednesday, November 14, 2018, meeting approved submitting the VATI Grant application for the Middlebrook Fiber Project with a 15% local match in the amount of \$52,114.00 and the Deerfield Fiber Project with a 15% local match in the amount of \$34,950.00.

Funding Source: 70-80000-8145 \$87,064.00

TKF/am

cc: Misty Cook, Director of Finance



December 3, 2018

LETTER OF COMMITMENT

Ms. Jennifer M. Whetzel
Deputy County Administrator
County of Augusta
Verona, Virginia 24482

RE: Deerfield Fiber Project (VATI 2019)

Dear Ms. Whetzel,

MGW/Lingo Networks (“Lingo”) is very pleased to be selected as Augusta County’s partnering provider in an application for broadband funding from the Virginia Telecommunications Initiative (VATI). As you and the other staff and elected officials know from our numerous meetings, Lingo is committed to helping Augusta County identify and implement broadband solutions in the rural, unserved areas of the county.

The intent of this letter is to affirm our financial commitment of \$34,950 included in the application for the broadband deployment solution in the Deerfield. As we’ve previously mentioned, we applaud Augusta County for your attentiveness to the telecommunications needs throughout your communities and your local investment will undoubtedly assist with the provision of broadband services in these high-cost, unserved areas.

Feel free to contact me with any questions you may have at (540) 448-1336 or by sending an email to craig.smith@mgwnetworks.com

Sincerely,
Lingo Networks

R. Craig Smith, President

FCC Form 477 Data for Deerfield Project Area

ProviderName	DBAName	CensusBlock	TechCode	MaxAdDown	MaxAdUp
MGW Telephone Company, Inc.	MGW Telephone	510150701003111	10	10	1
Rural Broadband Network Services LLC	HighSpeedLink.net	510150701003111	70	12	3
Rural Broadband Network Services LLC	HighSpeedLink.net	510150701003134	70	12	3
MGW Telephone Company, Inc.	MGW Telephone	510150701003135	10	10	1
Rural Broadband Network Services LLC	HighSpeedLink.net	510150701003135	70	12	3
MGW Telephone Company, Inc.	MGW Telephone	510150701003136	10	10	1
Rural Broadband Network Services LLC	HighSpeedLink.net	510150701003136	70	12	3
MGW Telephone Company, Inc.	MGW Telephone	510150701003147	10	10	1
Rural Broadband Network Services LLC	HighSpeedLink.net	510150701003147	70	12	3

The map below depicts approx. 3,070 census blocks (in red) reported by Rural Broadband Network Services, LCC (RBNS) including the 8 census blocks in the proposed project area (yellow outline). RBNS has reported providing fixed wireless internet of with speeds of 12/3 in the entire red area. If this was true, then broadband (>10/1 per VATI guidelines) would be available in 95% of the County. Based upon our local knowledge of the area and our survey results, we do not believe this information to be correct (we are not aware of ANY service provided by RBNS in this area) and that the Deerfield Fiber Project is meets the definition of unserved and is eligible for VATI.

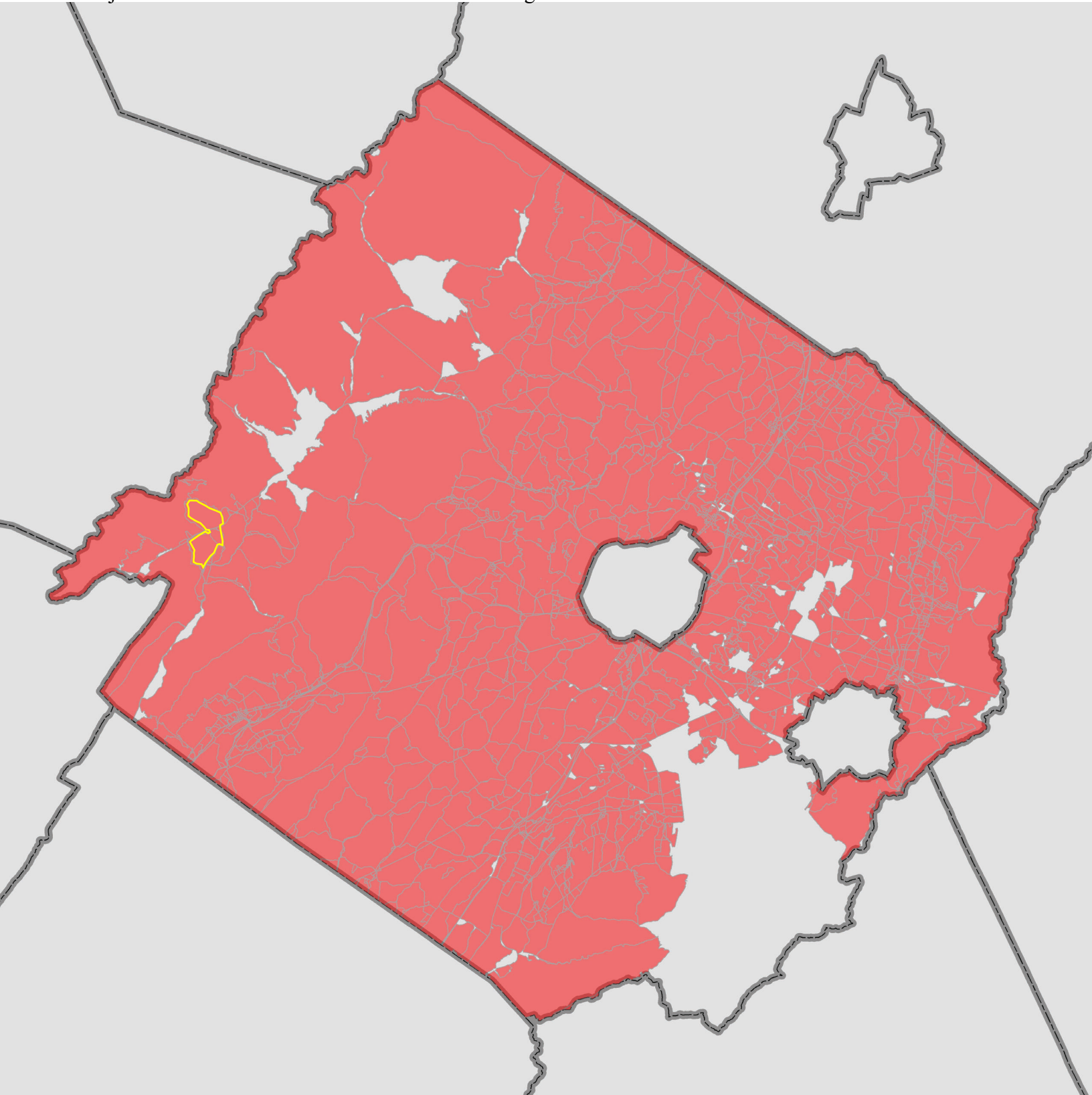

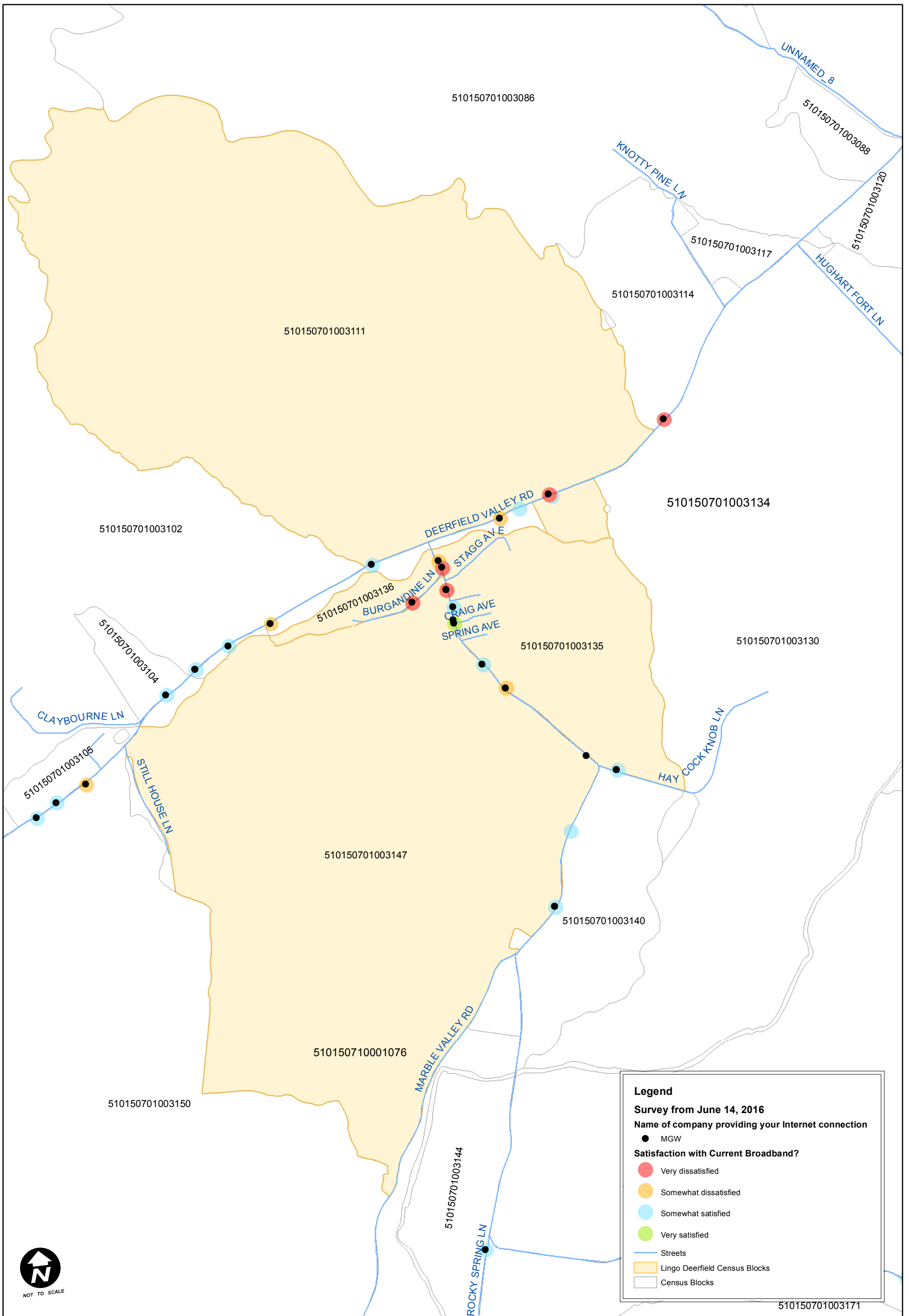

Deerfield Outreach Effort



The image below is a screenshot that was taken from the FCC's Connect America Fund Broadband Map. This interactive map shows the areas where Connect America Funding has been allocated. The proposed project area is not located in an area that has been designated to receive Connect America Funding (CAF). <https://data.usac.org/publicreports/caf-map/>



Connect America Fund Broadband Map

NOTE The dark green areas on this image represent areas that have been designated to receive CAF funding, and the light green areas represent National Forest as shown on the basemap used on the FCC's interactive map.

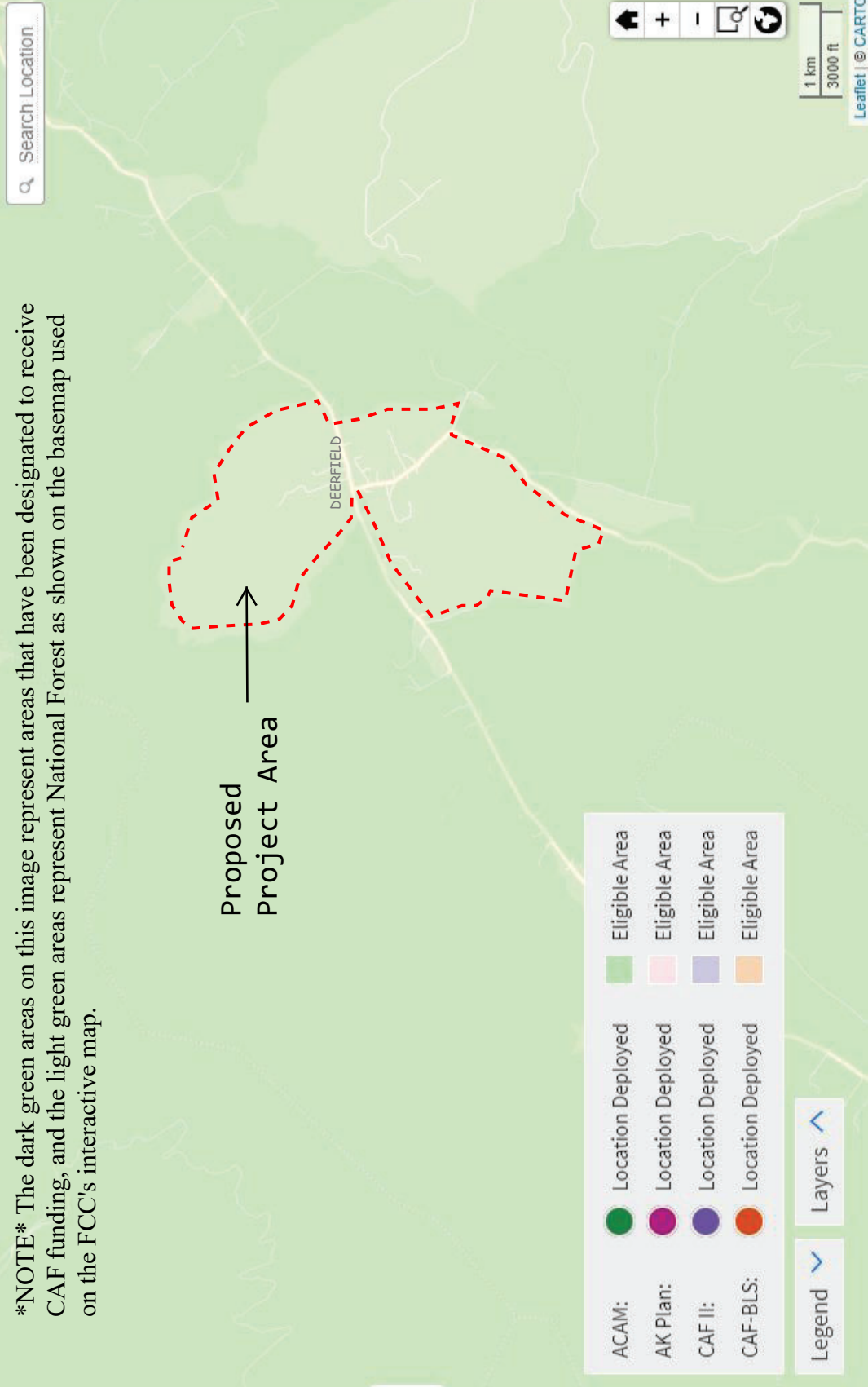

VATI 2019 Application - Augusta County - Deerfield Fiber Project

VATI FUNDING SOURCES TABLE

Please fill in the chart below with a description of the project funding source (local, federal, state, private, other), the amount from that source, the percentage of total project funding that source represents, and a description of the current status of the funds (pending, secured, etc.).

Source	Amount	%	Status
REQUESTED VATI	\$ 163,100	70	Pending
LOCAL	\$ 34,950	15	SECURED
PRIVATE	\$ 34,950	15	SECURED
	\$		
	\$		
	\$		
	\$		
TOTAL	\$ 233,000	100	

A G E N D A
REGULAR MEETING OF THE AUGUSTA COUNTY BOARD OF SUPERVISORS

WEDNESDAY, NOVEMBER 28, 2018, at 7:00 p.m.

Board Meeting Room, Government Center, Verona, VA

ITEM NO.	DESCRIPTION
7:00 P.M.	PLEDGE OF ALLEGIANCE INVOCATION - Public participation is optional; those who wish to join the Board of Supervisors in prayer are asked to remain standing after the Pledge.
PUBLIC HEARING:	
11-13	<u>CRESCENT DEVELOPMENT GROUP, LLC AND MYERS CORNER PARTNERS, LC – REZONING</u> Consider a request to rezone from Multi-Family Residential to General Business approximately 0.345 acres (portion of TMP 066C1-8-1 and portion of TMP 066C-8-11) owned by Crescent Development Group, LLC and Myers Corner Partners, LC located in the southwest quadrant of the intersection of Jefferson Highway (Route 250) and Myers Corner Drive in Fishersville in the Wayne District. The Planning Commission recommends approval.
11-14	<u>CRIMORA-MADRID AGRICULTURAL AND FORESTAL DISTRICT</u> Consider an ordinance amendment of Chapter 3 of the Augusta County Code for the Crimora-Madrid Agricultural and Forestal District located in the Middle River District lying between Route 784 (Pine Bluff Road) and Route 865 (Rockfish Road) and south of Route 612 (New Hope and Crimora Road). The amended approximate acreage of the district is 1,099. The amendment will renew the existing district, with additions, until November 24, 2028.
11-15	<u>MIDDLE RIVER AGRICULTURAL AND FORESTAL DISTRICT</u> Consider an ordinance amendment of Chapter 3 of the Augusta County Code for the Middle River Agricultural and Forestal District located in the Middle River District, lying east of Interstate 81; both east and west sides of Route 778 (Knightly Mill Road), Route 774 (Broad Run Road), Route 774 (Cline River Road), and Route 865 (Rockfish Road); both north and south sides of Route 608 (Battlefield Road), Route 775 (Buttermilk Road), and Route 775 (Craig Shop Road); on the north side of Route 777 (Knightly Lane); both north and south sides of Route 728 (Patterson Mill Road); on the southwest side of Route 774 (Piedmont Road). The amendment will clarify that parcels within the district are also located on Dam Town Road. The amended approximate acreage of the district is 5,575 acres. The amendment will renew the existing district, with the corrections, additions and removals, until November 24, 2028.

- 11-16 **LEASE OF BERRY FARM HAY AND PASTURE**
Consider authorizing the lease of the property owned by Augusta County, Virginia, Tax Map 36-19 and better known as the Berry Farm Hay and Pasture area in the Beverley Manor District.

**** (END OF PUBLIC HEARINGS) ****

- 11-17 **MATTERS TO BE PRESENTED BY THE PUBLIC*****Chairman Gerald Garber announced that this would be the time for the public to comment on Broadband.***

- 11-18 **REFUND REQUEST FOR STANLEY N. THOMPSON**
Consider a refund request from the Commissioner of the Revenue for Stanley N. Thompson in the amount of \$2,872.89.

- 11-19 **LEGISLATIVE AGENDA**
Consider final Legislative Agenda.

- 11-20 **COMMISSIONER OF REVENUE TAX PROGRAM**
Consider Tax Relief for the Elderly and Disabled.

- 11-21 **WAIVERS**

- 11-22 **CONSENT AGENDA**

- 11-22.1 **MINUTES**
Consider minutes of the following meeting:

- Regular Meeting, Wednesday, October 10, 2018
- Staff Briefing, Monday, October 22, 2018

(END OF CONSENT AGENDA)

- 11-23 **MATTERS TO BE PRESENTED BY THE BOARD**

- 11-24 **MATTERS TO BE PRESENTED BY STAFF**

- 11-25 **CLOSED SESSION**



Legal Notices

PUBLIC COMMENT PERIOD-2019 VATI GRANT

The County of Augusta is soliciting public comment before pursuing applications for the 2019 Virginia Telecommunications Initiative (VATI) Grant implemented by the Virginia Department of Housing and Community Development. The goal of the VATI grant is to enhance sustainability and competitive advantages of communities throughout the Commonwealth by preparing those communities to build, utilize, and capitalize on telecommunications infrastructure. The County received a proposal to partner for fiber projects in the areas of Rt. 252 from Arbor Hill to Middlebrook and in the Deerfield Valley Road and Marble Valley Road vicinities of the Deerfield community.

The Board of Supervisors will hear public comment on the grant at the November 28, 2018 regular meeting. The meeting begins at 7 pm and is held at the Government Center at 18 Government Center Lane, Verona, VA 24482. Written comments can be submitted to Information Technology at P.O. Box 590, Verona, VA 24482. If you have questions regarding the public comment, please call 540-245-5062.

0003760814-01

All County News

Font Size:    [Share & Bookmark](#) [Feedback](#)  [Print](#)

Internet Survey for Augusta County

Post Date: 11/16/2018 4:17 PM

The County of Augusta is soliciting public comment before pursuing an application for the 2019 *Virginia Telecommunications Initiative Grant* implemented by the Virginia DHCD.

The County received a proposal to partner for fiber projects in the areas of Rt. 252 from Arbor Hill to Middlebrook and in the Deerfield Valley Road and Marble Valley Road vicinities of the Deerfield community.

Please assist County officials in defining the need for improved internet service by completing the following survey.

<https://www.surveymonkey.com/r/AugustaCountyBroadband>

[Return to full list >>](#)

COUNTY OF AUGUSTA, VA.

BOARD OF SUPERVISORS

MARSHALL W. PATTIE
North River

GERALD W. GARBER
Middle River

PAMELA L. CARTER
Pastures

VACANT
Beverley Manor

WENDELL L. COLEMAN
Wayne

MICHAEL L. SHULL
Riverheads

CAROLYN S. BRAGG
South River



TIMOTHY K. FITZGERALD – COUNTY ADMINISTRATOR

AUGUSTA COUNTY GOVERNMENT CENTER

P.O. BOX 590, VERONA, VA 24482-0590

(540) 245-5610 FAX (540) 245-5621

coadmin@co.augusta.va.us

November 27, 2018

Property Owner
Deerfield Community

RE: Internet Survey

Dear Property Owner:

Augusta County is applying for a Virginia Telecommunications Initiative 2019 grant for portions of the Deerfield area. The project would include installation of fiber to the home. Your property may or may not be in the qualifying project area, however, your input is critical to beginning the process of extending service availability to unserved areas. Responses to the following questions will be included with public input for the grant:

Do you have internet service at your location? Yes No

If so, are you satisfied with your service? Yes No

Who is your current internet provider? Do Not Have

Thank you for taking the time to complete this short survey. Please return it in the enclosed envelope. If you are interested in completing the County's full Internet survey, go to www.co.augusta.va.us and see the survey under news and notices.

Sincerely,
County of Augusta

COUNTY OF AUGUSTA, VA.

BOARD OF SUPERVISORS

MARSHALL W. PATTIE
North River

GERALD W. GARBER
Middle River

PAMELA L. CARTER
Pastures

VACANT
Beverley Manor

WENDELL L. COLEMAN
Wayne

MICHAEL L. SHULL
Riverheads

CAROLYN S. BRAGG
South River

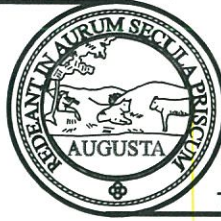

TIMOTHY K. FITZGERALD – COUNTY ADMINISTRATOR

AUGUSTA COUNTY GOVERNMENT CENTER

P.O. BOX 590, VERONA, VA 24482-0590

(540) 245-5610 FAX (540) 245-5621

coadmin@co.augusta.va.us

November 27, 2018

Property Owner
Deerfield Community

RE: Internet Survey

Dear Property Owner:

Augusta County is applying for a Virginia Telecommunications Initiative 2019 grant for portions of the Deerfield area. The project would include installation of fiber to the home. Your property may or may not be in the qualifying project area, however, your input is critical to beginning the process of extending service availability to unserved areas. Responses to the following questions will be included with public input for the grant:

Do you have internet service at your location?

Yes No

If so, are you satisfied with your service?

Yes No

Who is your current internet provider?

MGW

Thank you for taking the time to complete this short survey. Please return it in the enclosed envelope. If you are interested in completing the County's full Internet survey, go to www.co.augusta.va.us and see the survey under news and notices.

Sincerely,
County of Augusta

COUNTY OF AUGUSTA, VA.

BOARD OF SUPERVISORS

MARSHALL W. PATTIE
North River

GERALD W. GARBER
Middle River

PAMELA L. CARTER
Pastures

WENDELL L. COLEMAN
Wayne

VACANT
Beverley Manor

MICHAEL L. SHULL
Riverheads

CAROLYN S. BRAGG
South River



TIMOTHY K. FITZGERALD – COUNTY ADMINISTRATOR

AUGUSTA COUNTY GOVERNMENT CENTER

P.O. BOX 590, VERONA, VA 24482-0590

(540) 245-5610 FAX (540) 245-5621

coadmin@co.augusta.va.us

November 27, 2018

Property Owner
Middlebrook Community

RE: Internet Survey

Dear Property Owner:

Augusta County is applying for a Virginia Telecommunications Initiative 2019 grant for portions of the Middlebrook area. The project would include installation of fiber to the home. Your property may or may not be in the qualifying project area, however, your input is critical to beginning the process of extending service availability to unserved areas. Responses to the following questions will be included with public input for the grant:

Do you have internet service at your location?

Yes No

If so, are you satisfied with your service?

Yes No No/No!

Who is your current internet provider?

ATT

Thank you for taking the time to complete this short survey. Please return it in the enclosed envelope. If you are interested in completing the County's full Internet survey, go to www.co.augusta.va.us and see the survey under news and notices.

Sincerely,
County of Augusta

COUNTY OF AUGUSTA, VA.

BOARD OF SUPERVISORS

MARSHALL W. PATTIE
North River

GERALD W. GARBER
Middle River

PAMELA L. CARTER
Pastures

WENDELL L. COLEMAN
Wayne

VACANT
Beverley Manor

MICHAEL L. SHULL
Riverheads

CAROLYN S. BRAGG
South River



TIMOTHY K. FITZGERALD – COUNTY ADMINISTRATOR

AUGUSTA COUNTY GOVERNMENT CENTER

P.O. BOX 590, VERONA, VA 24482-0590

(540) 245-5610 FAX (540) 245-5621

coadmin@co.augusta.va.us

November 27, 2018

Property Owner
Deerfield Community

RE: Internet Survey

Dear Property Owner:

Augusta County is applying for a Virginia Telecommunications Initiative 2019 grant for portions of the Deerfield area. The project would include installation of fiber to the home. Your property may or may not be in the qualifying project area, however, your input is critical to beginning the process of extending service availability to unserved areas. Responses to the following questions will be included with public input for the grant:

Do you have internet service at your location? Yes No

If so, are you satisfied with your service? Yes No

Who is your current internet provider? _____

Thank you for taking the time to complete this short survey. Please return it in the enclosed envelope. If you are interested in completing the County's full Internet survey, go to www.co.augusta.va.us and see the survey under news and notices.

Sincerely,
County of Augusta

COUNTY OF AUGUSTA, VA.

BOARD OF SUPERVISORS

MARSHALL W. PATTIE North River	GERALD W. GARBER Middle River
PAMELA L. CARTER Pastures	WENDELL L. COLEMAN Wayne
VACANT Beverly Manor	
MICHAEL L. SHULL Riverheads	CAROLYN S. BRAGG South River

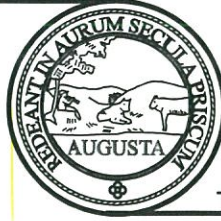

TIMOTHY K. FITZGERALD – COUNTY ADMINISTRATOR

AUGUSTA COUNTY GOVERNMENT CENTER

P.O. BOX 590, VERONA, VA 24482-0590

(540) 245-5610 FAX (540) 245-5621

coadmin@co.augusta.va.us

November 27, 2018

Property Owner
Deerfield Community

RE: Internet Survey

Dear Property Owner:

Augusta County is applying for a Virginia Telecommunications Initiative 2019 grant for portions of the Deerfield area. The project would include installation of fiber to the home. Your property may or may not be in the qualifying project area, however, your input is critical to beginning the process of extending service availability to unserved areas. Responses to the following questions will be included with public input for the grant:

Do you have internet service at your location? Yes No

If so, are you satisfied with your service? Yes No

Who is your current internet provider? Hughes Net

Thank you for taking the time to complete this short survey. Please return it in the enclosed envelope. If you are interested in completing the County's full Internet survey, go to www.co.augusta.va.us and see the survey under news and notices.

Sincerely,
County of Augusta

COUNTY OF AUGUSTA, VA.

BOARD OF SUPERVISORS

MARSHALL W. PATTIE
North River

GERALD W. GARBER
Middle River

PAMELA L. CARTER
Pastures

VACANT
Beverley Manor

WENDELL L. COLEMAN
Wayne

MICHAEL L. SHULL
Riverheads

CAROLYN S. BRAGG
South River



TIMOTHY K. FITZGERALD – COUNTY ADMINISTRATOR

AUGUSTA COUNTY GOVERNMENT CENTER

P.O. BOX 590, VERONA, VA 24482-0590

(540) 245-5610 FAX (540) 245-5621

coadmin@co.augusta.va.us

November 27, 2018

Property Owner
Deerfield Community

RE: Internet Survey

Dear Property Owner:

Augusta County is applying for a Virginia Telecommunications Initiative 2019 grant for portions of the Deerfield area. The project would include installation of fiber to the home. Your property may or may not be in the qualifying project area, however, your input is critical to beginning the process of extending service availability to unserved areas. Responses to the following questions will be included with public input for the grant:

Do you have internet service at your location? Yes No

If so, are you satisfied with your service? Yes No

Who is your current internet provider? _____

Thank you for taking the time to complete this short survey. Please return it in the enclosed envelope. If you are interested in completing the County's full Internet survey, go to www.co.augusta.va.us and see the survey under news and notices.

Sincerely,
County of Augusta

COUNTY OF AUGUSTA, VA.

BOARD OF SUPERVISORS

MARSHALL W. PATTIE
North River

GERALD W. GARBER
Middle River

PAMELA L. CARTER
Pastures

VACANT
Beverley Manor

WENDELL L. COLEMAN
Wayne

MICHAEL L. SHULL
Riverheads

CAROLYN S. BRAGG
South River



TIMOTHY K. FITZGERALD – COUNTY ADMINISTRATOR

AUGUSTA COUNTY GOVERNMENT CENTER

P.O. BOX 590, VERONA, VA 24482-0590

(540) 245-5610 FAX (540) 245-5621

coadmin@co.augusta.va.us

November 27, 2018

Property Owner
Deerfield Community

RE: Internet Survey

Dear Property Owner:

Augusta County is applying for a Virginia Telecommunications Initiative 2019 grant for portions of the Deerfield area. The project would include installation of fiber to the home. Your property may or may not be in the qualifying project area, however, your input is critical to beginning the process of extending service availability to unserved areas. Responses to the following questions will be included with public input for the grant:

Do you have internet service at your location?

Yes No

If so, are you satisfied with your service?

Yes No

Who is your current internet provider?

Hughes Net

Thank you for taking the time to complete this short survey. Please return it in the enclosed envelope. If you are interested in completing the County's full Internet survey, go to www.co.augusta.va.us and see the survey under news and notices.

Sincerely,
County of Augusta

COUNTY OF AUGUSTA, VA.

BOARD OF SUPERVISORS

MARSHALL W. PATTIE
North River

GERALD W. GARBER
Middle River

PAMELA L. CARTER
Pastures

WENDELL L. COLEMAN
Wayne

VACANT
Beverly Manor

MICHAEL L. SHULL
Riverheads

CAROLYN S. BRAGG
South River



TIMOTHY K. FITZGERALD – COUNTY ADMINISTRATOR

AUGUSTA COUNTY GOVERNMENT CENTER

P.O. BOX 590, VERONA, VA 24482-0590

(540) 245-5610 FAX (540) 245-5621

coadmin@co.augusta.va.us

November 27, 2018

Property Owner
Deerfield Community

RE: Internet Survey

Dear Property Owner:

Augusta County is applying for a Virginia Telecommunications Initiative 2019 grant for portions of the Deerfield area. The project would include installation of fiber to the home. Your property may or may not be in the qualifying project area, however, your input is critical to beginning the process of extending service availability to unserved areas. Responses to the following questions will be included with public input for the grant:

Do you have internet service at your location? Yes No

If so, are you satisfied with your service? Yes No

Who is your current internet provider? MGW

Thank you for taking the time to complete this short survey. Please return it in the enclosed envelope. If you are interested in completing the County's full Internet survey, go to www.co.augusta.va.us and see the survey under news and notices.

Sincerely,
County of Augusta

COUNTY OF AUGUSTA, VA.

BOARD OF SUPERVISORS

MARSHALL W. PATTIE
North River

GERALD W. GARBER
Middle River

PAMELA L. CARTER
Pastures

WENDELL L. COLEMAN
Wayne

VACANT
Beverley Manor

MICHAEL L. SHULL
Riverheads

CAROLYN S. BRAGG
South River

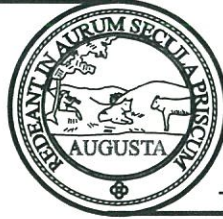

TIMOTHY K. FITZGERALD – COUNTY ADMINISTRATOR

AUGUSTA COUNTY GOVERNMENT CENTER

P.O. BOX 590, VERONA, VA 24482-0590

(540) 245-5610 FAX (540) 245-5621

coadmin@co.augusta.va.us

November 27, 2018

Property Owner
Deerfield Community

RE: Internet Survey

Dear Property Owner:

Augusta County is applying for a Virginia Telecommunications Initiative 2019 grant for portions of the Deerfield area. The project would include installation of fiber to the home. Your property may or may not be in the qualifying project area, however, your input is critical to beginning the process of extending service availability to unserved areas. Responses to the following questions will be included with public input for the grant:

Do you have internet service at your location? Yes No

If so, are you satisfied with your service? Yes No

Who is your current internet provider? _____

Thank you for taking the time to complete this short survey. Please return it in the enclosed envelope. If you are interested in completing the County's full Internet survey, go to www.co.augusta.va.us and see the survey under news and notices.

Sincerely,
County of Augusta

COUNTY OF AUGUSTA, VA.

BOARD OF SUPERVISORS

MARSHALL W. PATTIE North River	GERALD W. GARBER Middle River
PAMELA L. CARTER Pastures	WENDELL L. COLEMAN Wayne
MICHAEL L. SHULL Riverheads	CAROLYN S. BRAGG South River
VACANT Beverley Manor	



TIMOTHY K. FITZGERALD – COUNTY ADMINISTRATOR

AUGUSTA COUNTY GOVERNMENT CENTER

P.O. BOX 590, VERONA, VA 24482-0590

(540) 245-5610 FAX (540) 245-5621

coadmin@co.augusta.va.us

November 27, 2018

Property Owner
Deerfield Community

RE: Internet Survey

Dear Property Owner:

Augusta County is applying for a Virginia Telecommunications Initiative 2019 grant for portions of the Deerfield area. The project would include installation of fiber to the home. Your property may or may not be in the qualifying project area, however, your input is critical to beginning the process of extending service availability to unserved areas. Responses to the following questions will be included with public input for the grant:

Do you have internet service at your location? Yes No

If so, are you satisfied with your service? Yes No

Who is your current internet provider? None

Thank you for taking the time to complete this short survey. Please return it in the enclosed envelope. If you are interested in completing the County's full Internet survey, go to www.co.augusta.va.us and see the survey under news and notices.

Sincerely,
County of Augusta

COUNTY OF AUGUSTA, VA.

BOARD OF SUPERVISORS

MARSHALL W. PATTIE
North River

GERALD W. GARBER
Middle River

PAMELA L. CARTER
Pastures

VACANT
Beverley Manor

WENDELL L. COLEMAN
Wayne

MICHAEL L. SHULL
Riverheads

CAROLYN S. BRAGG
South River



TIMOTHY K. FITZGERALD – COUNTY ADMINISTRATOR

AUGUSTA COUNTY GOVERNMENT CENTER

P.O. BOX 590, VERONA, VA 24482-0590

(540) 245-5610 FAX (540) 245-5621

coadmin@co.augusta.va.us

November 27, 2018

Property Owner
Deerfield Community

RE: Internet Survey

Dear Property Owner:

Augusta County is applying for a Virginia Telecommunications Initiative 2019 grant for portions of the Deerfield area. The project would include installation of fiber to the home. Your property may or may not be in the qualifying project area, however, your input is critical to beginning the process of extending service availability to unserved areas. Responses to the following questions will be included with public input for the grant:

Do you have internet service at your location? Yes No

If so, are you satisfied with your service? Yes No

Who is your current internet provider? _____

Thank you for taking the time to complete this short survey. Please return it in the enclosed envelope. If you are interested in completing the County's full Internet survey, go to www.co.augusta.va.us and see the survey under news and notices.

Sincerely,
County of Augusta

COUNTY OF AUGUSTA, VA.

BOARD OF SUPERVISORS

MARSHALL W. PATTIE
North River

GERALD W. GARBER
Middle River

PAMELA L. CARTER
Pastures

VACANT
Beverley Manor

WENDELL L. COLEMAN
Wayne

MICHAEL L. SHULL
Riverheads

CAROLYN S. BRAGG
South River

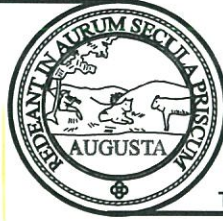

TIMOTHY K. FITZGERALD – COUNTY ADMINISTRATOR

AUGUSTA COUNTY GOVERNMENT CENTER

P.O. BOX 590, VERONA, VA 24482-0590

(540) 245-5610 FAX (540) 245-5621

coadmin@co.augusta.va.us

November 27, 2018

Property Owner
Deerfield Community

RE: Internet Survey

Dear Property Owner:

Augusta County is applying for a Virginia Telecommunications Initiative 2019 grant for portions of the Deerfield area. The project would include installation of fiber to the home. Your property may or may not be in the qualifying project area, however, your input is critical to beginning the process of extending service availability to unserved areas. Responses to the following questions will be included with public input for the grant:

Do you have internet service at your location? Yes No

If so, are you satisfied with your service? Yes No

Who is your current internet provider? _____

Thank you for taking the time to complete this short survey. Please return it in the enclosed envelope. If you are interested in completing the County's full internet survey, go to www.co.augusta.va.us and see the survey under news and notices.

Sincerely,
County of Augusta

COUNTY OF AUGUSTA, VA.

BOARD OF SUPERVISORS

MARSHALL W. PATTIE
North River

GERALD W. GARBER
Middle River

PAMELA L. CARTER
Pastures

VACANT
Beverley Manor

WENDELL L. COLEMAN
Wayne

MICHAEL L. SHULL
Riverheads

CAROLYN S. BRAGG
South River



TIMOTHY K. FITZGERALD – COUNTY ADMINISTRATOR

AUGUSTA COUNTY GOVERNMENT CENTER

P.O. BOX 590, VERONA, VA 24482-0590

(540) 245-5610 FAX (540) 245-5621

coadmin@co.augusta.va.us

November 27, 2018

Property Owner
Deerfield Community

RE: Internet Survey

Dear Property Owner:

Augusta County is applying for a Virginia Telecommunications Initiative 2019 grant for portions of the Deerfield area. The project would include installation of fiber to the home. Your property may or may not be in the qualifying project area, however, your input is critical to beginning the process of extending service availability to unserved areas. Responses to the following questions will be included with public input for the grant:

Do you have internet service at your location? Yes No

If so, are you satisfied with your service? Yes No

Who is your current internet provider?

MGW

Thank you for taking the time to complete this short survey. Please return it in the enclosed envelope. If you are interested in completing the County's full Internet survey, go to www.co.augusta.va.us and see the survey under news and notices.

Sincerely,
County of Augusta

COUNTY OF AUGUSTA, VA.

BOARD OF SUPERVISORS

MARSHALL W. PATTIE
North River

GERALD W. GARBER
Middle River

PAMELA L. CARTER
Pastures

VACANT
Beverley Manor

WENDELL L. COLEMAN
Wayne

MICHAEL L. SHULL
Riverheads

CAROLYN S. BRAGG
South River



TIMOTHY K. FITZGERALD – COUNTY ADMINISTRATOR

AUGUSTA COUNTY GOVERNMENT CENTER

P.O. BOX 590, VERONA, VA 24482-0590

(540) 245-5610 FAX (540) 245-5621

coadmin@co.augusta.va.us

November 27, 2018

Property Owner
Deerfield Community

RE: Internet Survey

Dear Property Owner:

Augusta County is applying for a Virginia Telecommunications Initiative 2019 grant for portions of the Deerfield area. The project would include installation of fiber to the home. Your property may or may not be in the qualifying project area, however, your input is critical to beginning the process of extending service availability to unserved areas. Responses to the following questions will be included with public input for the grant:

Do you have internet service at your location? Yes No

If so, are you satisfied with your service? Yes No

Who is your current internet provider? McW

*Am more interested
in cell service!*

Thank you for taking the time to complete this short survey. Please return it in the enclosed envelope. If you are interested in completing the County's full Internet survey, go to www.co.augusta.va.us and see the survey under news and notices.

Sincerely,
County of Augusta

COUNTY OF AUGUSTA, VA.

BOARD OF SUPERVISORS

MARSHALL W. PATTIE
North River

GERALD W. GARBER
Middle River

PAMELA L. CARTER
Pastures

VACANT
Beverley Manor

WENDELL L. COLEMAN
Wayne

MICHAEL L. SHULL
Riverheads

CAROLYN S. BRAGG
South River



TIMOTHY K. FITZGERALD – COUNTY ADMINISTRATOR

AUGUSTA COUNTY GOVERNMENT CENTER

P.O. BOX 590, VERONA, VA 24482-0590

(540) 245-5610 FAX (540) 245-5621

coadmin@co.augusta.va.us

November 27, 2018

Property Owner
Deerfield Community

RE: Internet Survey

Dear Property Owner:

Augusta County is applying for a Virginia Telecommunications Initiative 2019 grant for portions of the Deerfield area. The project would include installation of fiber to the home. Your property may or may not be in the qualifying project area, however, your input is critical to beginning the process of extending service availability to unserved areas. Responses to the following questions will be included with public input for the grant:

Do you have internet service at your location? Yes No

If so, are you satisfied with your service? Yes No

Who is your current internet provider? MGW

*Am more interested
in cell service!*

Thank you for taking the time to complete this short survey. Please return it in the enclosed envelope. If you are interested in completing the County's full Internet survey, go to www.co.augusta.va.us and see the survey under news and notices.

Sincerely,
County of Augusta

COUNTY OF AUGUSTA, VA.

BOARD OF SUPERVISORS

MARSHALL W. PATTIE North River	GERALD W. GARBER Middle River
PAMELA L. CARTER Pastures	WENDELL L. COLEMAN Wayne
VACANT Beverley Manor	
MICHAEL L. SHULL Riverheads	CAROLYN S. BRAGG South River

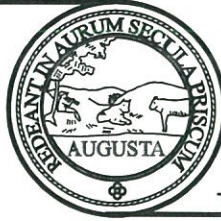

TIMOTHY K. FITZGERALD – COUNTY ADMINISTRATOR

AUGUSTA COUNTY GOVERNMENT CENTER

P.O. BOX 590, VERONA, VA 24482-0590

(540) 245-5610 FAX (540) 245-5621

coadmin@co.augusta.va.us

November 27, 2018

Property Owner
Deerfield Community

RE: Internet Survey

Dear Property Owner:

Augusta County is applying for a Virginia Telecommunications Initiative 2019 grant for portions of the Deerfield area. The project would include installation of fiber to the home. Your property may or may not be in the qualifying project area, however, your input is critical to beginning the process of extending service availability to unserved areas. Responses to the following questions will be included with public input for the grant:

Do you have internet service at your location? Yes No

If so, are you satisfied with your service? Yes No

Who is your current internet provider? Hughes Net

Thank you for taking the time to complete this short survey. Please return it in the enclosed envelope. If you are interested in completing the County's full Internet survey, go to www.co.augusta.va.us and see the survey under news and notices.

Sincerely,
County of Augusta

COUNTY OF AUGUSTA, VA.

BOARD OF SUPERVISORS

MARSHALL W. PATTIE
North River

GERALD W. GARBER
Middle River

PAMELA L. CARTER
Pastures

VACANT
Beverley Manor

WENDELL L. COLEMAN
Wayne

MICHAEL L. SHULL
Riverheads

CAROLYN S. BRAGG
South River



TIMOTHY K. FITZGERALD – COUNTY ADMINISTRATOR

AUGUSTA COUNTY GOVERNMENT CENTER

P.O. BOX 590, VERONA, VA 24482-0590

(540) 245-5610 FAX (540) 245-5621

coadmin@co.augusta.va.us

November 27, 2018

Property Owner
Deerfield Community

RE: Internet Survey

Dear Property Owner:

Augusta County is applying for a Virginia Telecommunications Initiative 2019 grant for portions of the Deerfield area. The project would include installation of fiber to the home. Your property may or may not be in the qualifying project area, however, your input is critical to beginning the process of extending service availability to unserved areas. Responses to the following questions will be included with public input for the grant:

Do you have internet service at your location? Yes No

If so, are you satisfied with your service? Yes No

Who is your current internet provider?

MGW

Thank you for taking the time to complete this short survey. Please return it in the enclosed envelope. If you are interested in completing the County's full Internet survey, go to www.co.augusta.va.us and see the survey under news and notices.

Sincerely,
County of Augusta

COUNTY OF AUGUSTA, VA.

BOARD OF SUPERVISORS

MARSHALL W. PATTIE
North River

PAMELA L. CARTER
Pastures

MICHAEL L. SHULL
Riverheads

VACANT
Beverley Manor

GERALD W. GARBER
Middle River

WENDELL L. COLEMAN
Wayne

CAROLYN S. BRAGG
South River



TIMOTHY K. FITZGERALD – COUNTY ADMINISTRATOR

AUGUSTA COUNTY GOVERNMENT CENTER

P.O. BOX 590, VERONA, VA 24482-0590

(540) 245-5610 FAX (540) 245-5621

coadmin@co.augusta.va.us

November 27, 2018

Property Owner
Deerfield Community

RE: Internet Survey

Dear Property Owner:

Augusta County is applying for a Virginia Telecommunications Initiative 2019 grant for portions of the Deerfield area. The project would include installation of fiber to the home. Your property may or may not be in the qualifying project area, however, your input is critical to beginning the process of extending service availability to unserved areas. Responses to the following questions will be included with public input for the grant:

Do you have internet service at your location? Yes No

If so, are you satisfied with your service? Yes No

Who is your current internet provider? MGW

Thank you for taking the time to complete this short survey. Please return it in the enclosed envelope. If you are interested in completing the County's full Internet survey, go to www.co.augusta.va.us and see the survey under news and notices.

Sincerely,
County of Augusta

COUNTY OF AUGUSTA, VA.

BOARD OF SUPERVISORS

MARSHALL W. PATTIE
North River

GERALD W. GARBER
Middle River

PAMELA L. CARTER
Pastures

VACANT
Beverley Manor

WENDELL L. COLEMAN
Wayne

MICHAEL L. SHULL
Riverheads

CAROLYN S. BRAGG
South River



TIMOTHY K. FITZGERALD – COUNTY ADMINISTRATOR

AUGUSTA COUNTY GOVERNMENT CENTER

P.O. BOX 590, VERONA, VA 24482-0590

(540) 245-5610 FAX (540) 245-5621

coadmin@co.augusta.va.us

November 27, 2018

Property Owner *our home*
Deerfield Community

RE: Internet Survey

Dear Property Owner:

Augusta County is applying for a Virginia Telecommunications Initiative 2019 grant for portions of the Deerfield area. The project would include installation of fiber to the home. Your property may or may not be in the qualifying project area, however, your input is critical to beginning the process of extending service availability to unserved areas. Responses to the following questions will be included with public input for the grant:

Do you have internet service at your location? Yes No

If so, are you satisfied with your service? Yes No

Who is your current internet provider?

MGW

Thank you for taking the time to complete this short survey. Please return it in the enclosed envelope. If you are interested in completing the County's full Internet survey, go to www.co.augusta.va.us and see the survey under news and notices.

Sincerely,
County of Augusta

COUNTY OF AUGUSTA, VA.

BOARD OF SUPERVISORS

MARSHALL W. PATTIE
North River

GERALD W. GARBER
Middle River

PAMELA L. CARTER
Pastures

VACANT
Beverley Manor

WENDELL L. COLEMAN
Wayne

MICHAEL L. SHULL
Riverheads

CAROLYN S. BRAGG
South River



TIMOTHY K. FITZGERALD – COUNTY ADMINISTRATOR

AUGUSTA COUNTY GOVERNMENT CENTER

P.O. BOX 590, VERONA, VA 24482-0590

(540) 245-5610 FAX (540) 245-5621

coadmin@co.augusta.va.us

November 27, 2018

Property Owner *our seasonal camp*
Deerfield Community

RE: Internet Survey

Dear Property Owner:

Augusta County is applying for a Virginia Telecommunications Initiative 2019 grant for portions of the Deerfield area. The project would include installation of fiber to the home. Your property may or may not be in the qualifying project area, however, your input is critical to beginning the process of extending service availability to unserved areas. Responses to the following questions will be included with public input for the grant:

Do you have internet service at your location? Yes No

If so, are you satisfied with your service? Yes No

Who is your current internet provider?

MGW

Thank you for taking the time to complete this short survey. Please return it in the enclosed envelope. If you are interested in completing the County's full Internet survey, go to www.co.augusta.va.us and see the survey under news and notices.

Sincerely,
County of Augusta

**REQUEST FOR INFORMATION
COUNTY OF AUGUSTA, VIRGINIA
Virginia Telecommunications Initiative (VATI) Grant Opportunity
RFI# 12010-19-1**

Purpose:

The County of Augusta is seeking one or more Internet Service Providers (ISPs) to partner with us to submit one or more applications for the 2019 Virginia Telecommunications Initiative (VATI) Grant opportunity. For more information on VATI, please review the [2019 Virginia Telecommunication Initiative Program Guidelines and Criteria](#) on the County's website at www.co.augusta.va.us.

Background:

The Department of Housing and Community Development will award funding to eligible applicants to provide last-mile services to unserved areas of the State. The funds shall be used for providing financial assistance to supplement construction costs by private sector broadband service providers to extend service to areas that presently are defined as unserved per grant guidelines. The private sector broadband service provider (ISP) must have a 477 form filed with the FCC. Applicants must be in good standing in performance of any and all existing Commonwealth of Virginia contracts, and compliance with all federal, state and local laws. **The project must be shovel ready in order to comply with the construction deadline of May 16, 2020.**

Requested Information:

Through this RFI; eligible ISPs are encouraged to submit one or more VATI Broadband Project Proposals which could be included in Augusta County's application(s) for VATI funding. Each project proposal must contain information identified in the sections noted in Attachment A, as well as the 2019 VATI Program Guidelines and Criteria in order to comply with grant submission requirements.

Desired Outcome:

The desired outcome is a partnership with one or more ISPs to effectively submit applications for VATI funding. The County reserves the option to partner with more than one ISP in this VATI effort.

Timeline:

Responses to this RFI are **due by 2:00 p.m. on Tuesday, October 30, 2018**. One (1) original and two (2) copies will be required. Responses and all communications regarding this RFI should be submitted to:

Jennifer Whetzel, Deputy County Administrator
County of Augusta
18 Government Center Lane
PO Box 590
Verona, Virginia 24482

The Augusta Internet Initiative Committee will review responses and assess the ability to submit a grant application. ISPs should be aware that they will be involved in the grant writing process; fielding questions and providing data as needed by the County to ensure a complete application.

Questions:

Questions with regard to this RFI can be sent to the attention of:

Jennifer Whetzel, Deputy County Administrator

Email: jwhetzel@co.augusta.va.us

Disclaimer:

Please be advised that this is a request for information only. This RFI does not constitute a request for proposal or a promise to issue an RFP in the future. This RFI is issued for the purposes of submittal of an application and potential approval of a VATI grant. This RFI and any responses to this RFI will be used in accordance with the 2019 VATI Program Guidelines and Criteria.

This RFI is neither a request nor a commitment by the County of Augusta, Virginia (the "County") to contract for any supply or service whatsoever. Furthermore, the County is not at this time seeking proposals and will not accept unsolicited proposals. Parties responding are advised that the County will not pay for any information or administrative costs incurred in response to this RFI; all costs associated with responding to this RFI will be solely at the interested party's expense.

ATTACHMENT A

(For a complete list of requirements, please review the Virginia Telecommunications Initiative (VATI) Grant 2019 Program Guidelines and Criteria on the County's website at www.co.augusta.va.us in its entirety.)

Project Area

1. Provide a map and description of the proposed geographic area including specific boundaries of the project area e.g.; street names, local and regional boundaries, etc. Explain why and how the project area(s) was selected. Attach a copy of your map(s).
2. Within the proposed project area, provide a map and list of all existing providers (fixed and wireless), estimate of customers serviced by these providers and speeds of service provided. Provide a detailed explanation of how this information was compiled and the source(s).

Project Need/Description

3. Provide documentation that demonstrates that the proposed project area(s) is unserved. An unserved area is defined as an area with speeds of 10 Mbps/1 Mbps or less, and with less than 10% service overlap within the project area. Describe the anticipated service overlap with current providers within the project area.
4. Describe population both in terms of absolute numbers within the project area and the eligible users that will be served by the proposed project. Describe the basis for these projections.
5. Indicate the numbers of businesses and community anchor institutions the proposed project will pass in the project area.
6. Provide the anticipated take rate for the proposed service within one year of project completion and describe the basis for the estimate. Also provide all actions to be implemented to reach the identified potential customers within the project area.
7. A statement whether the proposed project is targeting the "last mile," "middle mile," or "backbone" portion of the broadband infrastructure.
8. For wireless projects only: Please explain the ownership of the proposed wireless infrastructure. Will the wireless ISP own or lease the radio mast, tower, or other raised structure onto which the wireless infrastructure will be installed?
9. Provide a description of the broadband service to be provided, including

estimated download and upload speeds, whether that speed is based on dedicated or shared bandwidth, and the technology that will be used. This description can be illustrated by a map or schematic diagram, as appropriate.

10. Provide a description of the network system design used to deliver broadband service from the network's primary Internet point(s) of presence to end users, including the network components that already exist and the ones that would be added by the proposed project. Also describe specific advantages of using this technology. Provide a detailed explanation on how this information was compiled and source(s). For wireless projects, provide a propagation map including the proposed project.

Project Readiness

11. Describe the current state of project development (i.e. planning, preliminary engineering, final design, etc.)?
12. Prepare a detailed project timeline or construction schedule, which identifies specific tasks, staff, contractor responsible(s), collection of data, etc., and estimated start and completion dates. The timeline should include all activities being completed within 12 months of contract execution with DHCD (or no later than May 16, 2020).
13. Provide a description of the matching funds the ISP and County will need to invest in the proposed project, (VATI funding cannot exceed 80% of total project cost).
14. The County as applicant will assist the ISP as co-applicant with a description of the public-private partnership involved in the project.
15. Identify key individuals, including name and title, who will be responsible for the management of the project. Describe their role and responsibilities for the project.

Project Budget and Cost Appropriateness

16. Provide a detailed budget as to how the grant funds will be utilized, including an itemization of equipment and construction costs and a justification of proposed expenses. Expenses should be substantiated by clear cost estimates.
17. A description of ISP's history or experience with managing grants and constructing broadband communications facilities in the Commonwealth of Virginia and elsewhere.

Service Provision

18. Describe the Internet service offerings to be provided after completion of this project and your price structure for these services. The service offerings should include all relevant tiers.

Additional Information

19. Any other equitable factor that the ISP desires to include.

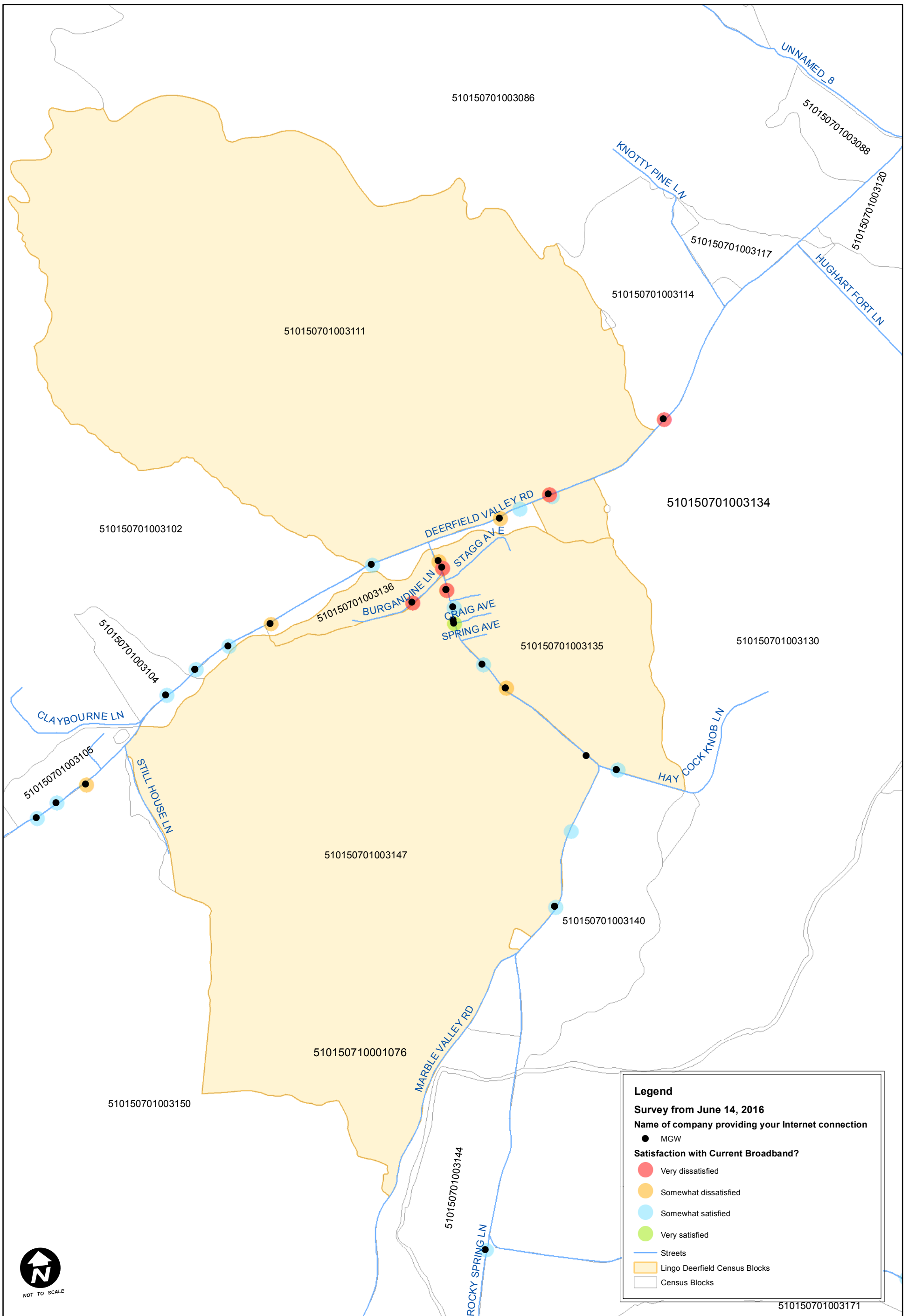

Deerfield Outreach Effort



FCC Form 477 Data for Deerfield Project Area

ProviderName	DBAName	CensusBlock	TechCode	MaxAdDown	MaxAdUp
MGW Telephone Company, Inc.	MGW Telephone	510150701003111	10	10	1
Rural Broadband Network Services LLC	HighSpeedLink.net	510150701003111	70	12	3
Rural Broadband Network Services LLC	HighSpeedLink.net	510150701003134	70	12	3
MGW Telephone Company, Inc.	MGW Telephone	510150701003135	10	10	1
Rural Broadband Network Services LLC	HighSpeedLink.net	510150701003135	70	12	3
MGW Telephone Company, Inc.	MGW Telephone	510150701003136	10	10	1
Rural Broadband Network Services LLC	HighSpeedLink.net	510150701003136	70	12	3
MGW Telephone Company, Inc.	MGW Telephone	510150701003147	10	10	1
Rural Broadband Network Services LLC	HighSpeedLink.net	510150701003147	70	12	3

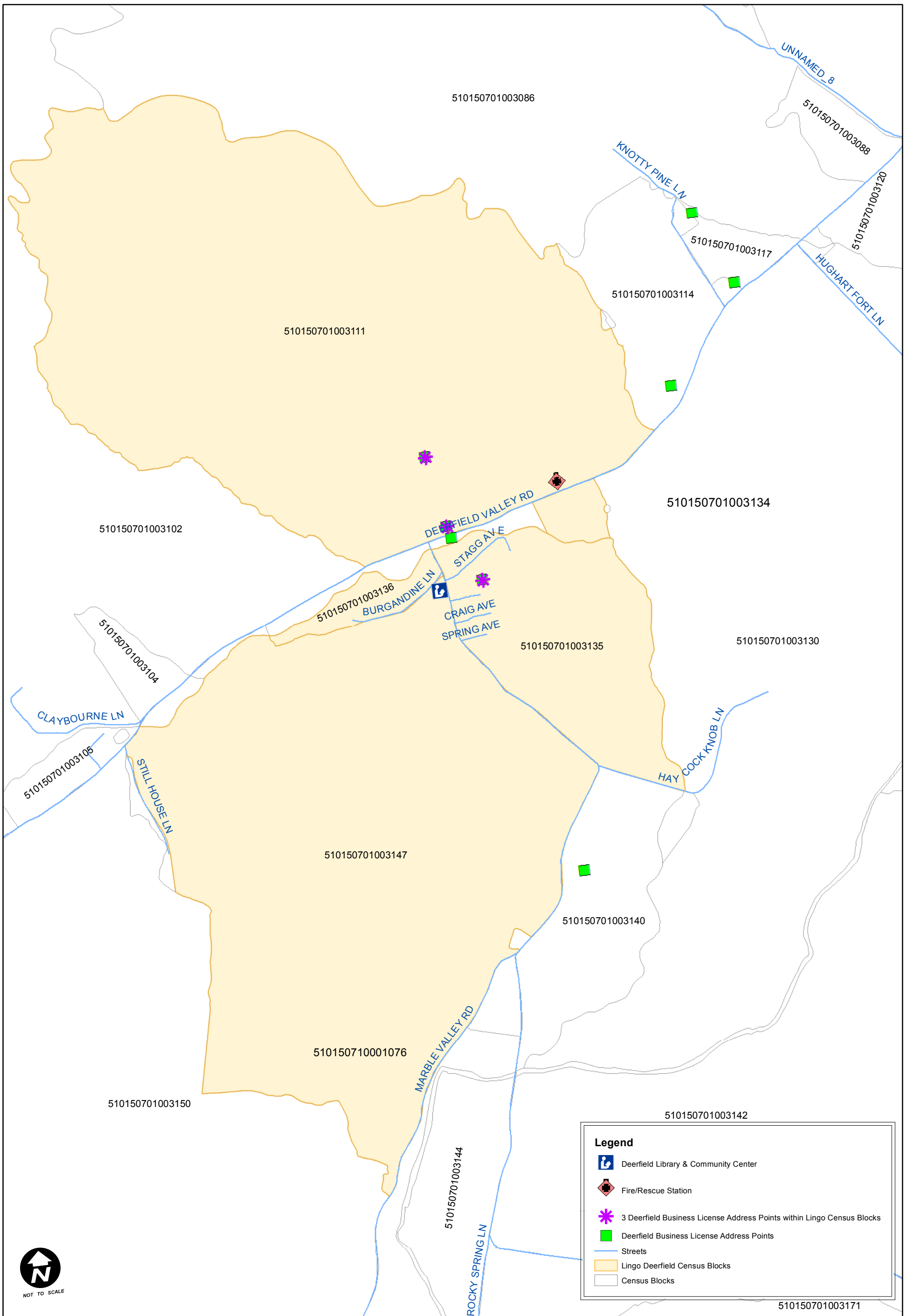

Deerfield Businesses and Anchor Institutions





NETWORK DIAGRAM

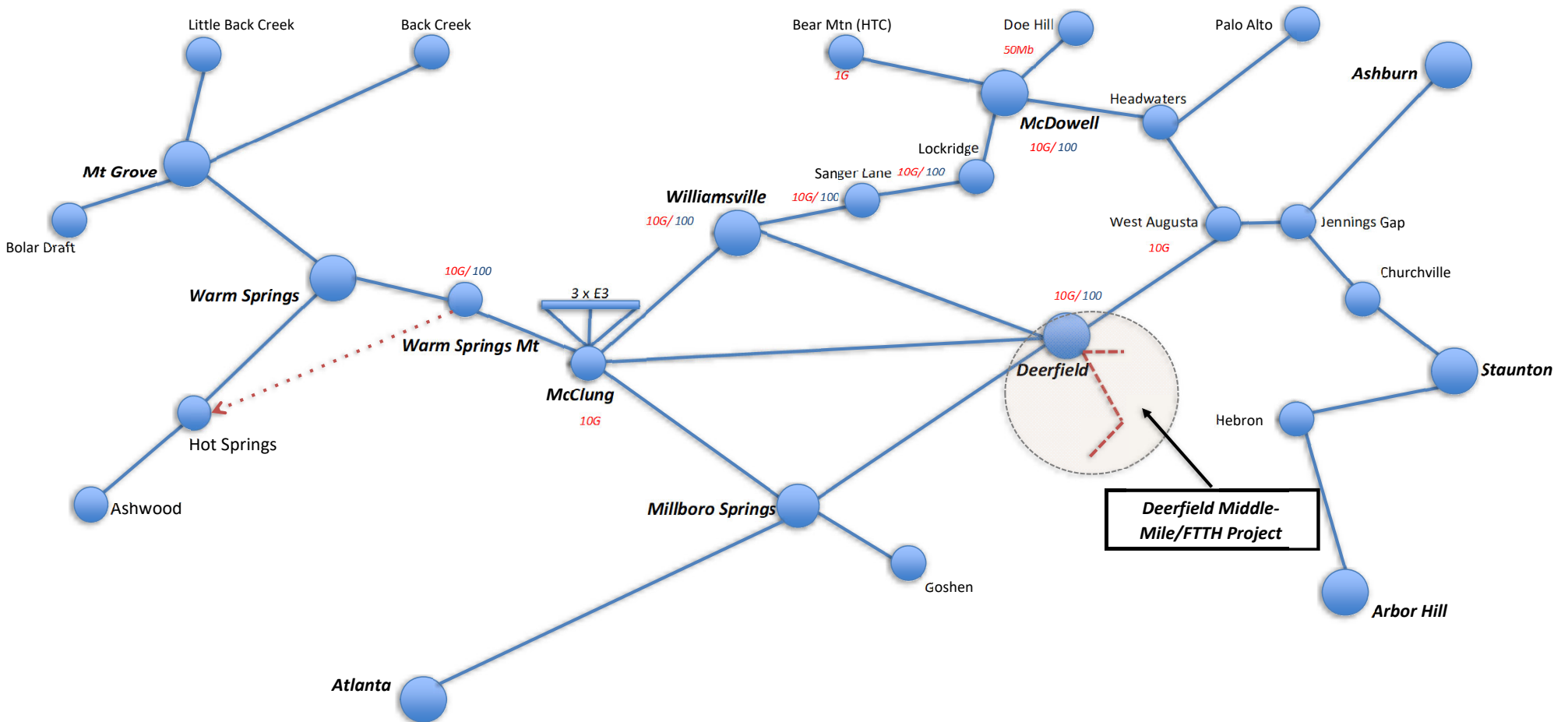

Fiber Network Architecture to serve Funded Census Blocks

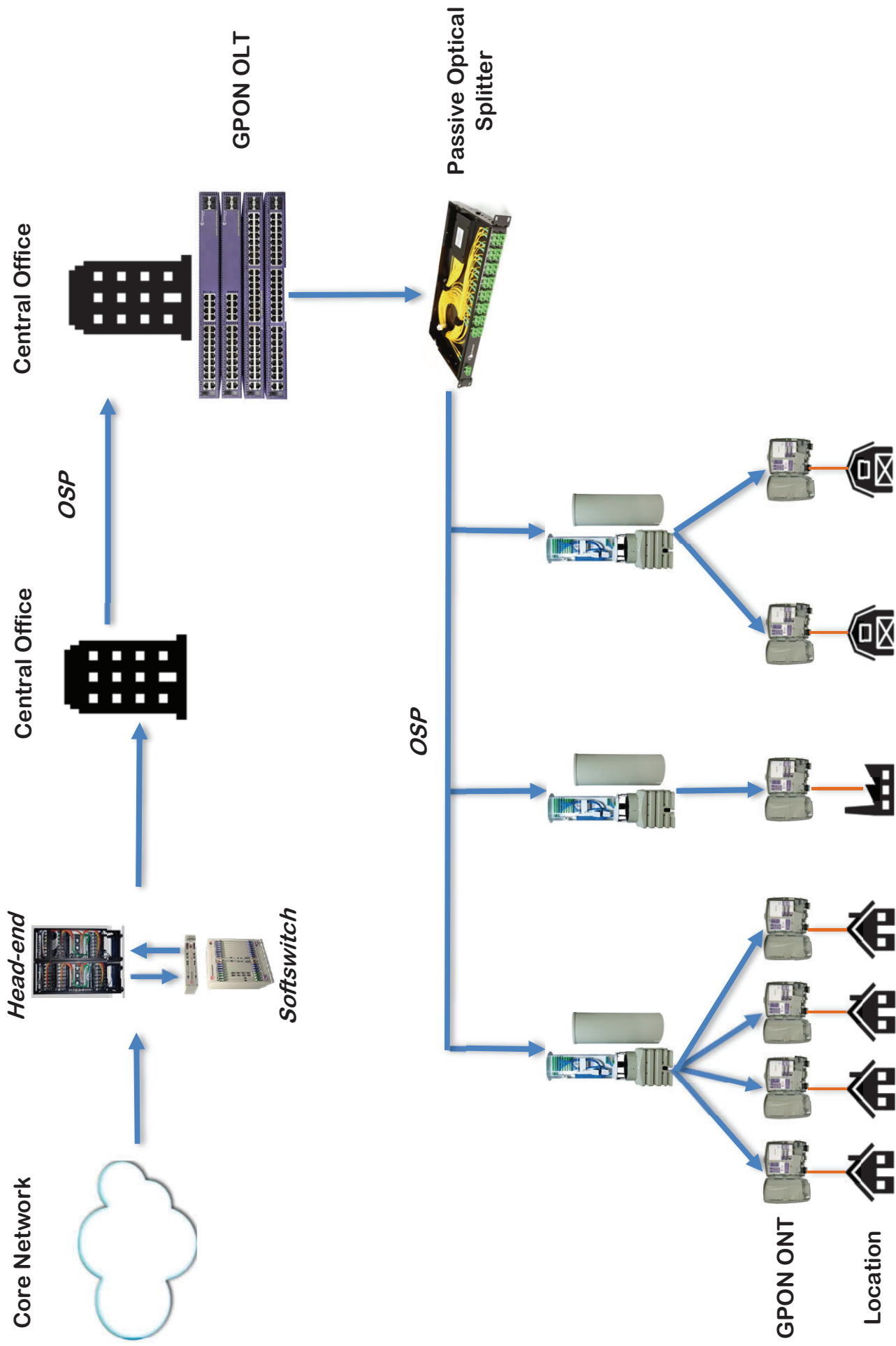

VATI 2019 Application - Augusta County - Deerfield Fiber Project

Key Individuals Assigned to Project		
<u>Name</u>	<u>Title</u>	<u>Responsibilities</u>
Craig Smith	President, MGW/Lingo Networks	Community and County liaison; Oversee startup, implementation and construction of the project, transition to final service products
Tony McCune	Network Operation Manager, MGW/Lingo Networks	Oversee installation of fiber and electronic equipment
Ryan Smith	Vice President, MGW/Lingo Networks	Manage customer service during transition and after
Robert Huff	Director of Strategic Planning, MGW/Lingo Networks	Planning and grant management
Jennifer Whetzel	Deputy County Administrator, Augusta County	Draft, submit grant application; Grant management if awarded
Jackie Zetwick	IT Director, Augusta County	Assist with project oversight for County interests